

SHARP®



COMMERCIAL APPLIANCES

Built To Meet Rugged Commercial Standards

TwinTouch™ Microwaves • Medium & Heavy-Duty Microwave Ovens • High Speed Oven • Rice Cooker

Innovation and Quality

JUST WHAT TODAY'S COMMERCIAL KITCHENS ARE ORDERING

Tested For Performance and Durability

Committed to meeting the high-performance needs of a wide range of food service environments, Sharp Electronics consistently offers innovative products and an industry-best on-site warranty. The latest line of commercial microwave ovens are not only packed with the most in-demand features, they are subjected to rigorous testing and evaluation methods to ensure dependability and durability in settings that include fast or full-service restaurants, hospitals and nursing homes, school cafeterias, convenience stores, and more. For added convenience, most ovens feature stainless steel interiors and exteriors that resist pitting, chipping, scratching, and corrosion, and are very easy to clean and maintain.

Kitchen Type	We recommend...
Fast Food, Utilizing Vertical Space	TwinTouch™ or Heavy-Duty Ovens
Quick Service	
Small, Convenience	Medium Duty Oven
Small, Great for Bread Products	High Speed Convection Oven

The Right Product For Every Purpose

Innovative Technology, Easily Within Your Reach

After carefully listening to countless restaurant needs and requests, Sharp developed and patented the Twin-Touch™ dual control panel. Even when ovens are positioned high on a counter or stacked, the unique TwinTouch dual control panel operation allows accurate, easy operation by virtually all personnel, regardless of height.

Small On Space, Big On Quality

Combining high-quality material and sophisticated design, Sharp's medium-duty microwave ovens are built to last. Ideal for convenience stores, break rooms, hospitals, and other small and low- to mid-volume settings that do not rely heavily on microwave cooking, these ovens fit easily in smaller kitchens that need a durable, efficient product for heating up foods.

Expand The Menu, Not The Kitchen

In situations where a full-sized oven is not necessary, Sharp high-speed convection ovens produce quality bread products quickly. The ability to easily serve fresh warm bread products or small "finger" foods is a great way to expand menus and satisfy appetites.



On-Site Appliance Servicing

SHARP STAYS AT THE FOREFRONT OF THE INDUSTRY BY STANDING BEHIND THEIR PRODUCTS

To maximize kitchen efficiency and minimize downtime, Sharp currently offers the industry's finest warranties, which include parts, labor, and on-site servicing. The Sharp Service and Support Group determines the best way to service commercial products, often deploying a technician to the location within one to two business days.

Heavy-Duty Microwave Ovens

BUILT FOR THE DEMANDS OF THE TOUGHEST KITCHEN

Cook It Fast, Cook It Right

Heavy-duty microwave ovens from Sharp are built for volume use and speed cooking. Designed for busy kitchens where speed and efficiency are essential, stackability brings added convenience, while rugged construction equals exceptional value that's built to last. The Heavy-Duty series offers a range of wattage output to avoid purchasing units that are over or underpowered. This allows kitchens to be outfitted to specific cooking needs and ultimately keeps electricity costs down.

These heavy-duty commercial microwaves are packed with features: For starters, the large (0.7 cubic foot) interior can easily accommodate a half-sized steam table pan with plenty of room for proper handling. Four power output capabilities (standard on all Sharp heavy-duty ovens) enable customization and optimal cooking time. Plus, durable latch handles, the ability to stack multiple units, high-quality stainless steel interiors and exteriors, and more. Other features include:

- **Memory:** stores up to 20 program inputs; recalls the memories at any time to confirm power level and time setting
- **3-Stage Programming** – Program food to defrost then begin cooking at one power level and finish cooking at another.
- **SelectaPower™** provides 11 variable power levels for more precise control
- **SelectaTime™** enables manual time input
- **Select from 2 audible tones** that signal the end of the cooking cycle, or switch off for silent operation
- **Double Quantity Button** automatically adjusts time for a double portion
- **Express Defrost™** automatically divides total defrosting time into 3 stages with 3 power levels
- **Counter Check** feature keeps tabs on oven usage, tallying how often each button is used and the number of manual inputs
- **Lighted Digital Display** shows time setting and countdown that is easy to read



R-25JTF 2100 watts
 R-24GTF 1800 watts
 R-23GTF 1600 watts
 R-22GTF 1200 watts

3 year limited warranty

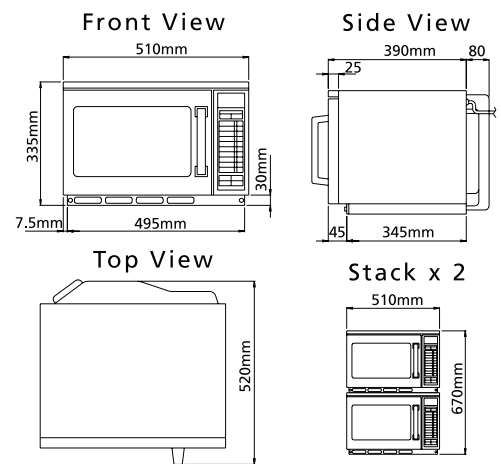

		Wattage Output						
		800	1000	1200	1600	1800	2100	2700
Cook Time mm:ss	00:30	00:24	00:20	00:15	00:13	00:11	00:09	
	1:00	00:48	00:40	00:30	00:27	00:23	00:18	
	1:30	01:12	01:00	00:45	00:40	00:34	00:27	
	2:00	01:36	01:20	01:00	00:53	00:46	00:36	
	5:00	04:00	03:20	02:30	02:13	01:54	01:29	
	10:00	08:00	06:40	05:00	04:27	03:49	02:58	



TwinTouch™ Microwave Ovens

THE FOOD SERVICE INDUSTRY'S FIRST DUAL CONTROL OVEN OPERATION

Easy To Reach, Wherever You Place It

Having a kitchen with stacked appliances or high counters can make it difficult for workers to maintain efficiency—especially when quick cooking and high volume are important. The answer? Sharp TwinTouch™ microwave ovens feature dual touch sensitive control panels: one on the top, and one on the bottom, allowing users of virtually any height to easily operate it, regardless of placement. Improved accessibility can boost both efficiency and productivity, while also increasing safety.

Appliances, particularly microwave ovens, are often stacked in order to save valuable counter space. Placement of control panels at the top of many microwave ovens makes it difficult for many staff members to reach. They sometimes resort to using tools or other objects to reach and operate the oven, creating dangerous situations. Sharp TwinTouch microwave ovens were designed in response to concerns over both the functionality and the safety of today's kitchens.





Two 1/3-size steam table pans will fit side-by-side for greater flexibility and higher volume cooking.

It also will accommodate a 1/2-size steam table pan in either direction with room to spare.

A Second Control Panel Isn't The Only Extra Feature:

The TwinTouch oven also incorporates convenience that kitchen personnel desire with improved durability that management demands. The TwinTouch is able to accommodate a half-size pan in either direction or two 1/3-size pans side by side. This capacity capability allows more food to be cooked in a given amount of time.

- **0.75 cubic-foot capacity**, with the same high-quality stainless steel interior and exterior
- **Manual and Memory Programming** – has 10 pre-programmed memory pads that easily convert up to 100 memories or can be programmed manually for special needs or times
- **4-Stage Programming** – enables users to program in 4 stages with different power levels and cooking time
- **Double/Triple Quantity Pads** – automatically adjusts to provide optimum heating times for two or three portions
- **More Features:**
 - Self-diagnostics, auto voltage sensor, and interior exhaust fan all help to improve the unit's lifespan
 - Express Defrost™
 - 11 variable power levels

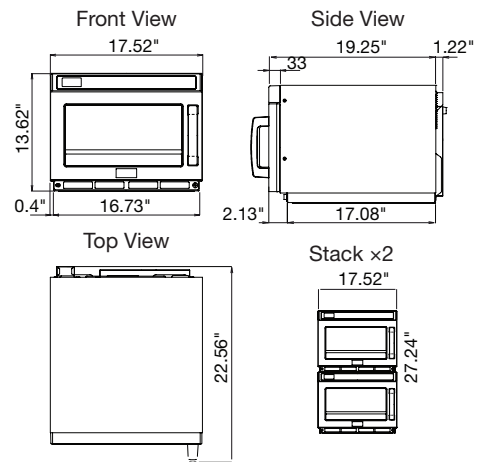

R-CD2200M
2200 watts
3-year warranty



R-CD1800M
1800 watts
3-year warranty



R-CD1200M
1200 watts
3-year warranty



Medium-Duty Microwave Ovens

QUALITY AND DEPENDABILITY THAT GO ABOVE AND BEYOND

Heating Appliance When You Need It

Perfect for smaller kitchens that do not require volume cooking, Sharp medium-duty microwave ovens feature a generous **1.0 cubic-foot capacity** and a convenient **1,000-watt power output**. They're ideal for defrosting, heating up or cooking small food items, and bring a new dimension of dependability to break rooms, hospitals, convenience stores, gas stations, and countless other settings. An array of easy-to-use features and one-touch controls add versatility—without added costs of using a high-powered microwave or oven.

Featuring stainless steel interior and exterior doors, these durable units stand up well to day-to-day use and are built to last. Strong, specially designed latch handles reduce door failure, one of the most frequent problems on units of lesser quality.



R-21LCF 1000 watts
1-year limited warranty



R-21LVF 1000 watts
1-year limited warranty



R-21LTF 1000 watts
3-year limited warranty

R-21LCF

Dependable 6-Minute Electronic Dial Timer – is clearly marked in 10, 15 and 30-second increments. When the door is opened during cooking, the remaining time is cancelled. This is a vast improvement over mechanical dial models that continue counting down after food was removed – wasting energy and reducing the magnetron's life.

Heating Time Guide – recommends times for heating a variety of popular foods. It's a handy “on-the-spot” reference for timesaving convenience.

R-21LVF

Computerized Touch Controls – provides 10 programmable memories with one-second increment timing; built-in safeguards prevent unauthorized changes.

Double Quantity Pad – automatically provides optimum heating times for two portions for excellent results.

Express Defrost™ – automatically divides total defrosting time into 3 stages with 3 power levels.

Memory Check – lets the user confirm the time setting and power level for each memory pad.

R-21LTF (includes features above)

Two-Way Programming – use any of the pre-programmed memories or manually program up to 20 of your own.

3-Stage Programming – program food to defrost then begin cooking at one power level and finish cooking at another.

Counter Check – lets the oven “remember” how often each feature was used plus the total number of manual uses so managers can keep closer tabs on operation.

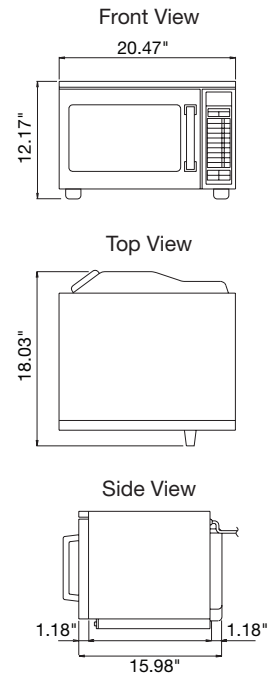

High-Speed Convection

INCREASED CAPACITY MEANS ADDITIONAL VALUE

Expand Capabilities While Controlling Costs

The Sharp commercial high-speed convection offers kitchens the benefits of expanding their menus without the dramatic costs of buying and operating a full-sized oven. A great multi-functioning oven, it also allows restaurants with limited space to offer some popular bread product items, such as small personal pizzas, nachos, hot sandwiches, and more... without sacrificing fast service.

A convenient selection of 60 automatic and pre-programmed settings for appetizers, snacks, meat, fish, poultry, baked goods, and many others make it simple to select a program and walk away – letting Sharp technology do the rest. This oven employs a revolutionary system to circulate super-heated air within the 1.1 cubic-foot oven cavity. A high-speed fan moves air from the top and side in variable speeds, automatically adjusting airflow to ensure that every item is prepared to perfection. This oven will even add microwave power as needed. As a result, foods are baked, browned, and crisped in less time.

- **3-Line, 30-Character Display** prompts step-by-step programming directions.
- **Audible Signal Elimination** for silent operation.
- **Refresh Cycle** removes offensive odors that may accumulate in the oven.
- **Counter Check** tracks total feature usage, to see what is being used the most.
- **Carousel® Turntable System** ensures uniform cooking with a 13" diameter porcelain turntable.
- **Temperature Control** 100°, 150°, and 275° to 450°F in 25° increments.
- **Ready On** function keeps the oven heated and ready to cook at 300°F.



R-8000G
1-year limited warranty

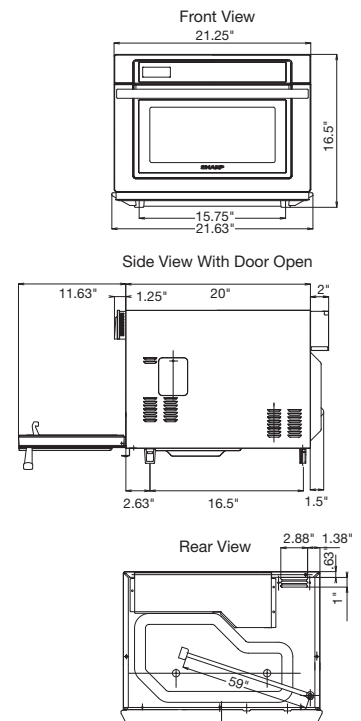

Large-Capacity Rice Cooker

Large Value—Even For Small Portions

The Sharp commercial rice cooker features extra-large capacity, easy-to-set controls, and includes a silicone sheet that will prevent any sticking or overbrowning, this rice cooker is perfect for restaurants that want to expand their rice offerings.

- **Holds up to** 38 six-ounce cups of raw rice or 120 three-ounce servings of cooked rice.
- **Quick cooking** from 30 to 60 minutes depending on the type and quantity of rice.
- **Thermostatic control** maintains even temperature and can keep rice warm automatically after it has been cooked.
- **One-touch operation** lets you simply depress the cook button to begin full cook/keep warm cycle.







KSH-777DW
1-year limited warranty





Product Specifications

TWINTOUCH™





HIGH SPEED CONVECTION

Model Number:	R-CD2200M	R-CD1800M	R-CD1200M	R-8000G
Oven Control:	Dual control panels	Dual control panels	Dual control panels	Auto-Touch Controls
Output Power (IEC):	2200W	1800W	1200W	1000W
Cabinet and Oven Interior:	Stainless steel	Stainless steel	Stainless steel	Stainless steel cabinet and interior
Special Features:	10 pre-programmed, 100 total Memories, Double/Triple Quantity, Express Defrost™, 4-stage programming, Auto Voltage Sensor	10 pre-programmed, 100 total Memories, Double/Triple Quantity, Express Defrost, 4-stage programming, Auto Voltage Sensor	10 pre-programmed, 100 total Memories, Double/Triple Quantity, Express Defrost, 4-stage programming, Auto Voltage Sensor	Automatic Cooking, SelectaProgram™, SelectaTime™, SelectaPower™, Memory Check, Counter Check, Minute Plus Custom Help®, Double/Triple Quantity
Variable Power Levels SelectaPower™:	11 (0-100%)	11 (0-100%)	11 (0-100%)	11
Cavity Dimensions: (W × H × D)	14" × 7 1/8" × 13"	14" × 7 1/8" × 13"	14" × 7 1/8" × 13"	16 1/8" × 8 3/8" × 13 5/8" 1.1 cu. ft.
Outside Dimensions: (W × H × D)	17 1/2" × 13 5/8" × 20 1/2"	17 1/2" × 13 5/8" × 20 1/2"	17 1/2" × 13 5/8" × 20 1/2"	21 5/8" × 16 1/2" × 25 1/4"
Approximate Weight:	70 lbs / 72 lbs	70 lbs / 72 lbs	65 lbs / 67 lbs	86 lbs / 95 lbs
AC Power Required:	230/208V, 60 Hz, 3.2kW 14.0A @ 230V; 16.0A @ 208V	230/208V, 60 Hz, 2.7kW 12.3A @ 230V; 13.5A @ 208V	120V, 60 Hz, 1.9kW, 16.0A	208V, 60 Hz, 20A
NEMA Receptacle:	6-20R 	6-15R 	5-20R 	NEMA 6-20P/R 
UPC:	074000617315	074000617308	074000617292	074000611856

HEAVY-DUTY MICROWAVE OVENS

Model Number:	R-25JTF	R-24GTF	R-23GTF	R-22GTF
Oven Control:	Touch sensitive pads	Touch sensitive pads	Touch sensitive pads	Touch sensitive pads
Output Power (IEC):	2100W	1800W	1600W	1200W
Cabinet and Oven Interior:	Stainless steel cabinet and interior	Stainless steel cabinet and interior	Stainless steel cabinet and interior	Stainless steel cabinet and interior
Special Features:	20 Memories, Double Quantity, 3-stages, Express Defrost, Memory Check	20 Memories, Double Quantity, 3-stages, Express Defrost, Memory Check	20 Memories, Double Quantity, 3-stages, Express Defrost, Memory Check	20 Memories, Double Quantity, 3-stages, Express Defrost, Memory Check
Variable Power Levels SelectaPower™:	11	11	11	11
Cavity Dimensions: (W × H × D)	13" × 7 1/8" × 13" 0.7cu. ft.	13" × 7 1/8" × 13" 0.7cu. ft.	13" × 7 1/8" × 13" 0.7cu. ft.	13" × 7 1/8" × 13" 0.7cu. ft.
Outside Dimensions: (W × H × D)	20 1/8" × 13 1/4" × 18 1/2"	20 1/8" × 13 1/4" × 18 1/2"	20 1/8" × 13 1/4" × 18 1/2"	20 1/8" × 13 1/4" × 18 1/2"
Approximate Weight:	68 lbs / 77 lbs	65 lbs / 72 lbs	63 lbs / 69 lbs	60 lbs / 66 lbs
AC Power Required:	230/208V, 60 Hz, 3.2kW, 17.5A	230/208V, 60 Hz, 2.9kW, 16A	230/208V, 60 Hz, 2.5 kW, 13A	120V, 60Hz, 2.0kW, 17A
NEMA Receptacle:	6-20R 	6-20R 	6-15R 	5-20R 
UPC:	074000607880	074000611757	074000611740	074000611733

MEDIUM DUTY MICROWAVE OVENS

Model Number:	R-21LTF	R-21LVF	R-21LCF	KSH-777DW
Oven Control:	Touch sensitive pads with Braille	Touch sensitive pads with Braille	Electronic Light Up Dial with Auto Cancel	One -Touch
Output Power (IEC):	1000W	1000W	1000W	1700W
Heater Power:	—	—	—	—
Cabinet and Oven Interior:	Stainless steel cabinet and interior	Stainless steel cabinet and interior	Cool gray cabinet, stainless steel interior and door	Stainless steel Top and Replaceable aluminum interior
Special Features:	20 Memories, Double Quantity, Express Defrost, 3-stages, Memory Check	10 Memories, Double Quantity, Express Defrost, Memory Check	Heating Time Guide, 6-minute coded, Light Up Dial timer, Auto Cancel	Automatic Keep Warm, Silicone Liner, Thermostatic Control for Even Cooking
Variable Power Levels SelectaPower™:	11	100% only	100% only	—
Cavity Dimensions: (W × H × D)	13 7/8" × 8 1/8" × 14 5/8" 1.0 cu. ft.	13 7/8" × 8 1/8" × 14 5/8" 1.0 cu. ft.	13 7/8" × 8 1/8" × 14 5/8" 1.0 cu. ft.	—
Outside Dimensions: (W × H × D)	20 1/2" × 12 1/8" × 16"	20 1/2" × 12 1/8" × 16"	20 1/2" × 12 1/8" × 16"	19 1/16" × 13 3/4" × 17 1/16"
Approximate Weight: Net / Shipping	37 lbs / 44 lbs	37 lbs / 44 lbs	37 lbs / 44 lbs	20.3 lbs / 23.1 lbs
AC Power Required:	120V, 60 Hz, 1.6kW, 14A	120V, 60 Hz, 1.6kW, 14A	120V, 60 Hz, 1.6kW, 14A	—
NEMA Receptacle:	5-15R 	5-15R 	5-15R 	5-15R 
UPC:	074000616509	074000616486	074000616493	074000611955