

SHARP

INSTALLATION INSTRUCTIONS

BUILT-IN KIT MODEL

RK-12S30

IMPORTANT: This Built-In Kit is designed for use with Sharp SuperSteam Ovens specifying a RK-12S30 Built-In Kit on the rating label on the front of the oven.

The cabinet or wall opening must be within the following dimensions:

HEIGHT 19" to 19 1/8" (482 mm - 486 mm)
 WIDTH 28" to 28 1/4" (710 mm - 719 mm)
 DEPTH 23 1/4" minimum (509.5 mm minimum)

The completed built-in kit frame assembly dimensions:

HEIGHT 19 1/2" (495mm)
 WIDTH 30" (762mm)

NOTE: The bottom of the cut-out opening for built-in use must be 36 inches (915 mm) or higher from the floor.
PLEASE READ THESE INSTRUCTIONS THOROUGHLY BEFORE BEGINNING INSTALLATION!
 The electrical requirements for this oven are 120 volts, 15 amps. The oven has a 5-15 plug and requires a 5-15 receptacle.

PROVIDED PARTS

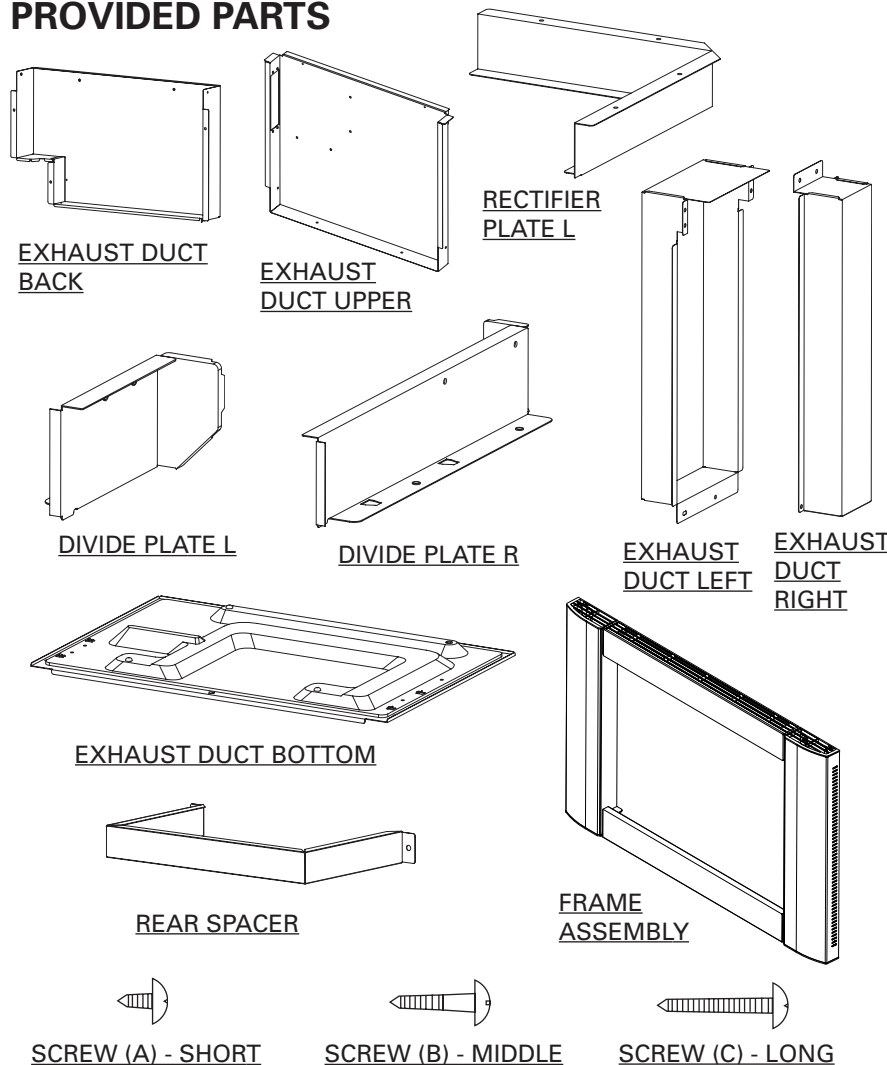

PART NAME	Q'TY
EXHAUST DUCT BACK PDVC-B107WRWZ	1
EXHAUST DUCT UPPER PDVC-B105WRWZ	1
DIVIDE PLATE L PSKR-A486WRWZ	1
DIVIDE PLATE R PSKR-A487WRWZ	1
RECTIFIER PLATE L PSKR-A484WRWZ	1
EXHAUST DUCT LEFT PDVC-B108WRWZ	1
EXHAUST DUCT RIGHT PDVC-B117WRWZ	1
EXHAUST DUCT BOTTOM PDVC-B106WRWZ	1
FRAME ASSEMBLY FDEC-A004WRKZ	1
SCREW(A) XHTS740P08000	23
SCREW(B) XMMS841P13000	2
SCREW(C) XMSS827P25000	4
REAR SPACER PSPAFA003WRWZ	1
CUSHION ① 5/8" x 16", 15 mm x 405 mm PCUS-A245WRPZ	2
CUSHION ② 1/4" x 24 3/8", 5 mm x 618 mm PCUS-A247WRPZ	1
CUSHION ③ 1 1/8" x 27 1/8", 30 mm x 689 mm PCUS-A249WRPZ	1
CUSHION ④ 1/4" x 12", 5 mm x 305 mm PCUS-A251WRPZ	1
CUSHION ⑤ 1/4" x 15", 5 mm x 382 mm PCUS-A253WRPZ	1

- * For walls other than wood, you may need screws appropriate for that wall to install the frame.
- * Be sure to DISCONNECT THE PLUG of the oven from the electrical outlet before installing the oven and kit.
- * Because the kits are metal, due caution should be used in handling and installation to avoid the possibility of injury.

PREPARATION

Follow the directions from 1 to 5 to attach cushions to some parts.

1. EXHAUST DUCT UPPER

Remove the backing paper from each CUSHION ①.
Attach the CUSHIONS ① to each side flange of the EXHAUST DUCT UPPER as shown in the illustration below.

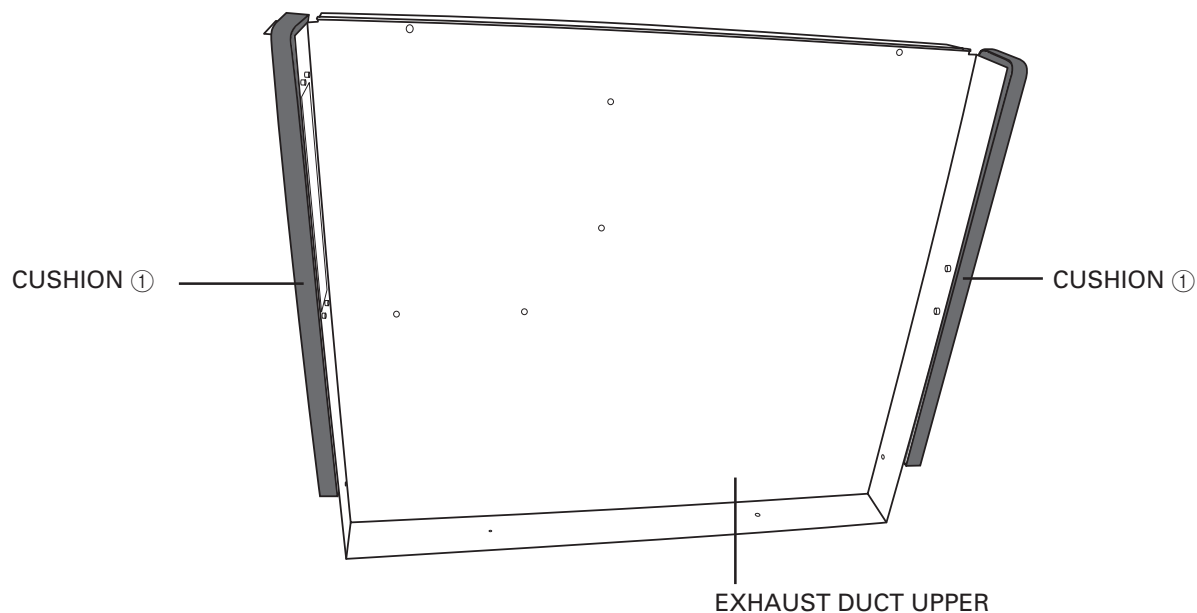

2. EXHAUST DUCT BACK

Remove the backing paper from CUSHION ②.
Attach the CUSHION ② at the lower flange of the EXHAUST DUCT BACK as shown in the illustration below.

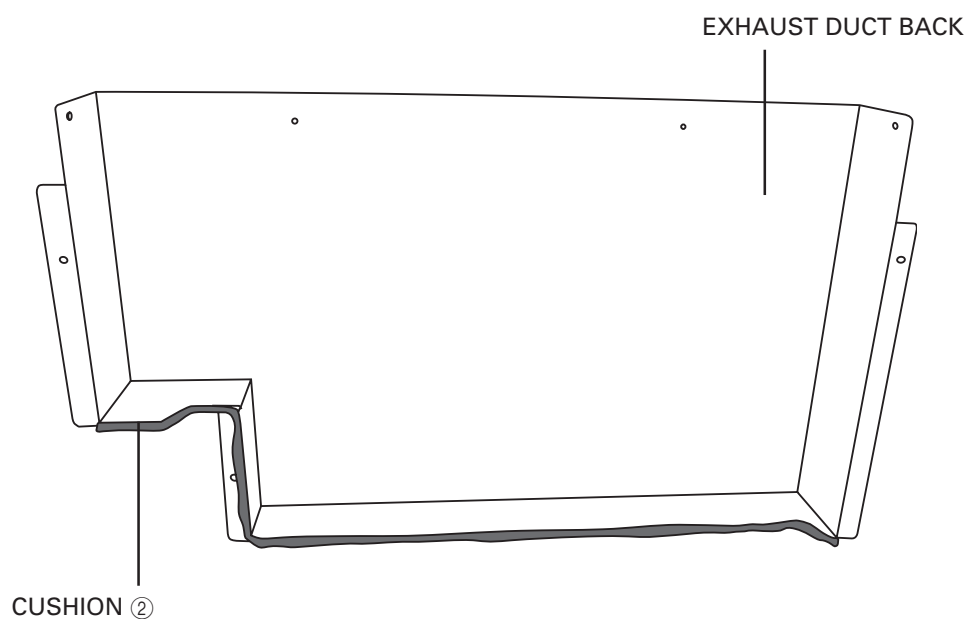

3. EXHAUST DUCT BOTTOM

Remove the backing paper from CUSHION ③.
Attach the CUSHION ③ to the EXHAUST DUCT BOTTOM as shown in the Illustration below.
* Start A to attach the CUSHION ③.

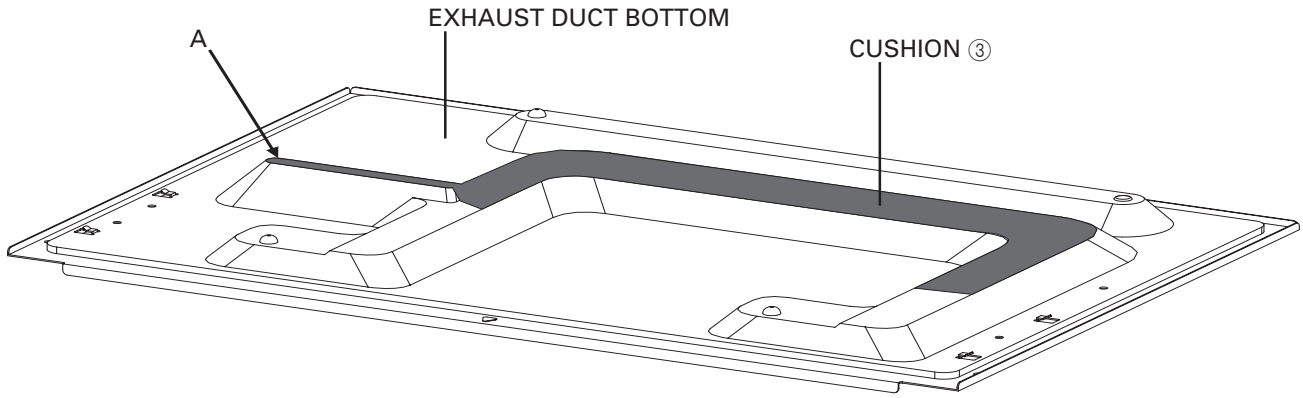

4. DIVIDE PLATE L

Remove the backing paper from CUSHION ④.
Attach the CUSHION ④ to the DIVIDE PLATE L as shown in the Illustration below.

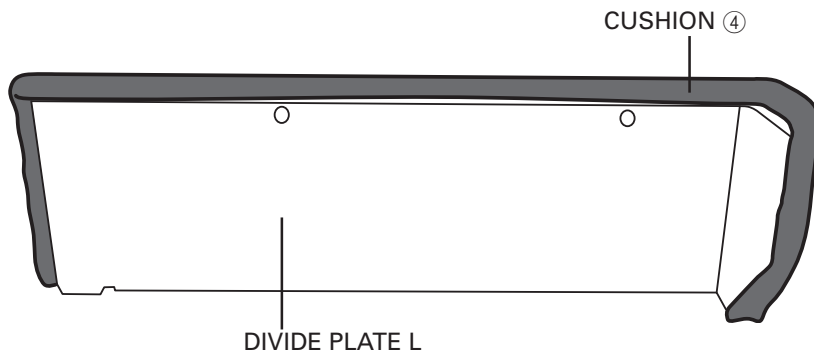

5. DIVIDE PLATE R

Remove the backing paper from CUSHION ⑤.
Attach the CUSHION ⑤ to the DIVIDE PLATE R as shown in the Illustration below.

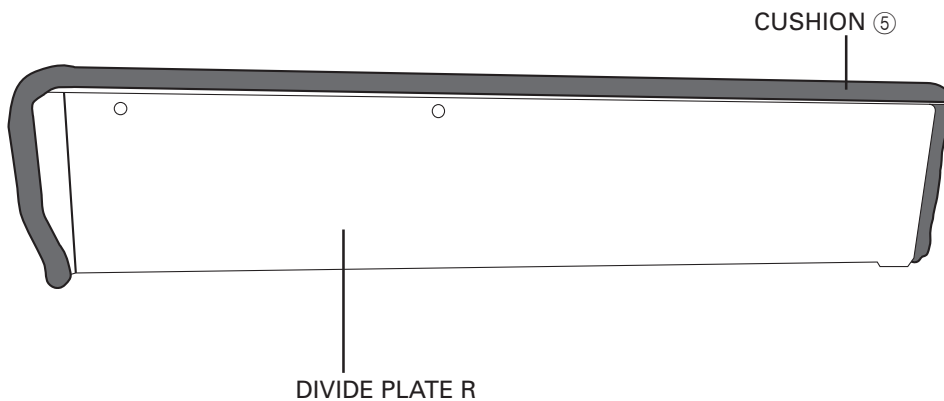

STEP 1: CABINET OR WALL OPENING

Provide an opening in the wall or cabinet shown in Figure 1. The depth should be minimum 23 1/4" (590.5 mm). The floor of the opening should be constructed of plywood strong enough to support the weight of the oven (about 150 lbs., 68.1 kg) and should be level for proper operation of the oven.

NOTE: While the proper functioning of the oven does not require that the opening be enclosed (with sides, ceiling and rear partition), this may be required by local code, and it is suggested that the local code be checked for any such requirement.

ELECTRICAL SUPPLY

At the rear of the opening, provide a 3 pronged, polarized, electrical outlet, 120 volt A.C., 15 amp. or larger. This outlet should be located in the shaded area of Figure 1. It is exceedingly important that the outlet be 120 volts and 15 amps. for optimum oven performance.

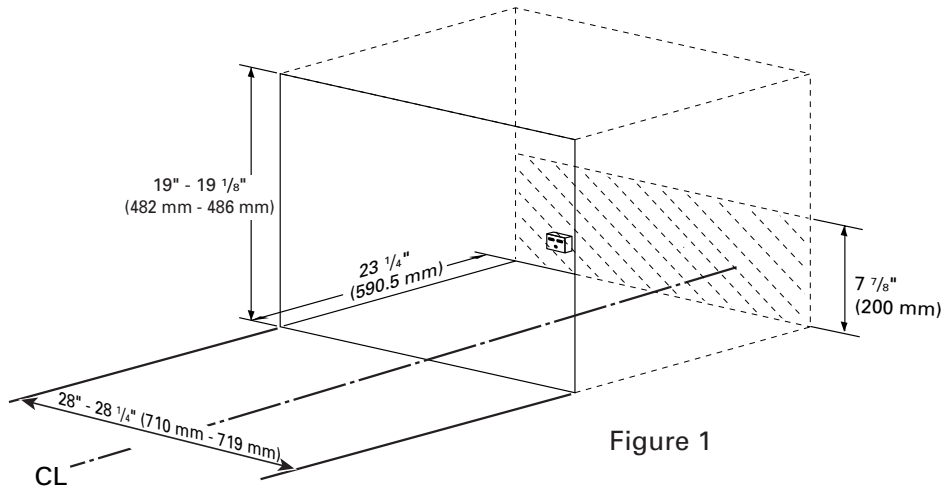

Figure 1

STEP 2: INSTALLATION OF EXHAUST DUCT BOTTOM & DIVIDE PLATE L/R

It is recommended that a sheet of cardboard or other protective material should be placed on the table or countertop to prevent damage to the surface during assembly.

- ① Place DIVIDE PLATE L/R over 2 catches on EXHAUST DUCT BOTTOM.
- ② Lock them into EXHAUST DUCT BOTTOM by sliding DIVIDE PLATE L/R in the direction of the arrow as shown in Figure 2-A.
- ③ Tighten 4 SCREWS (A) from the bottom at the left and right sides as shown in Figures 2 and 2-A.

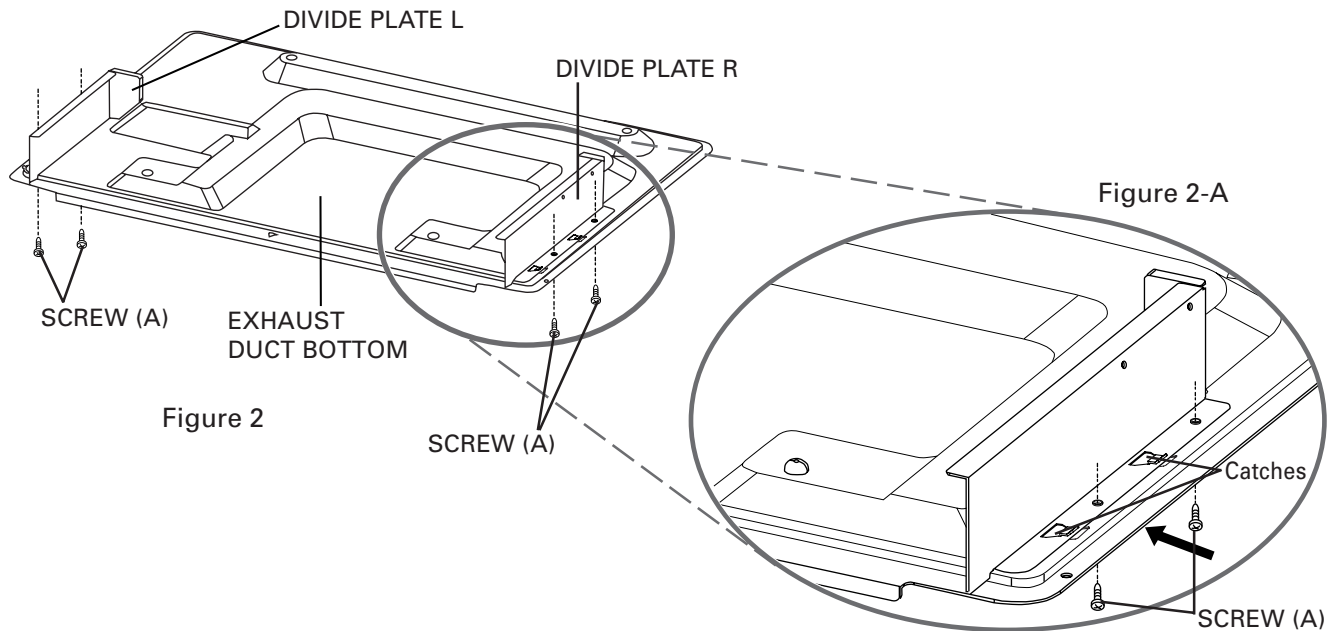
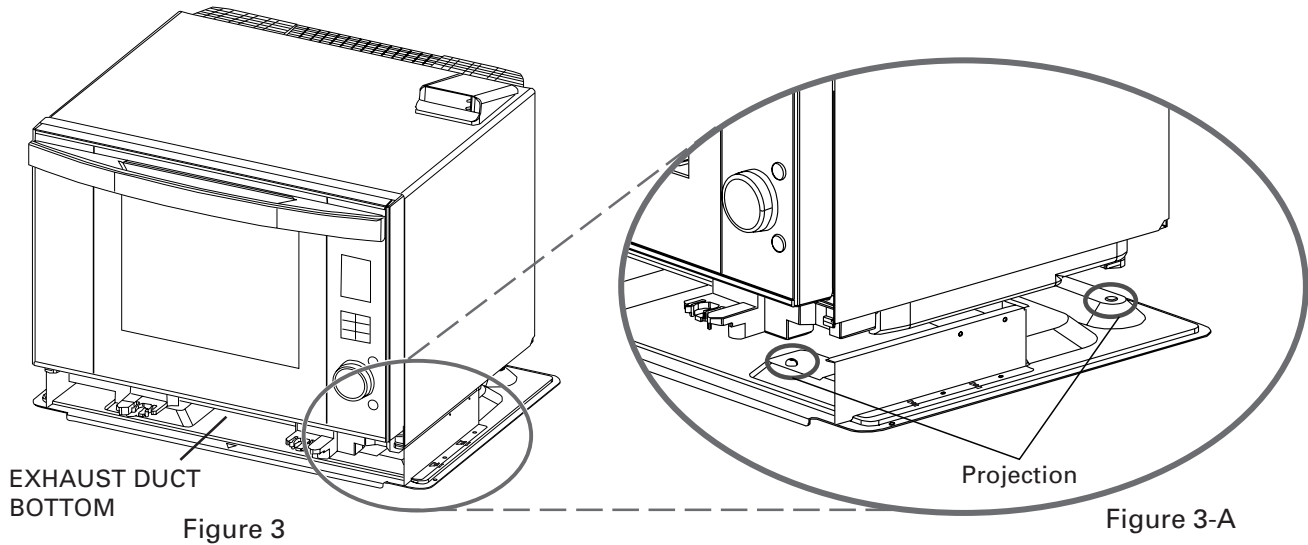

Figure 2

Figure 2-A

STEP 3: EXHAUST DUCT BOTTOM INSTALLATION

- ① Place the oven onto the EXHAUST DUCT BOTTOM, lowering the 4 feet of the oven onto the projections at the 4 corners of EXHAUST DUCT BOTTOM as shown in Figure 3-A.



STEP 4: EXHAUST DUCT BACK INSTALLATION

- ① Remove 2 screws (#1) from upper both sides of the oven as shown in Figure 4-A to install the EXHAUST DUCT BACK. (Save 2 screws to be used at step 4-②.)

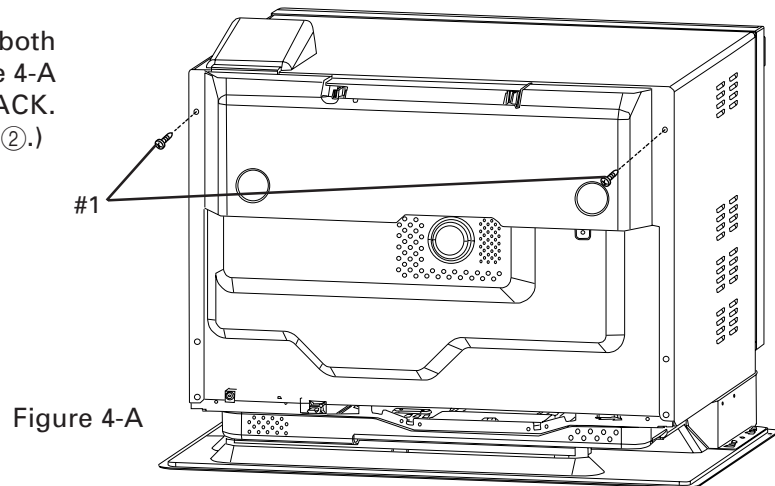

- ② Secure EXHAUST DUCT BACK to the oven with the screws (#1) removed at step 4-① and a SCREW (A) as shown in Figure 4-B.

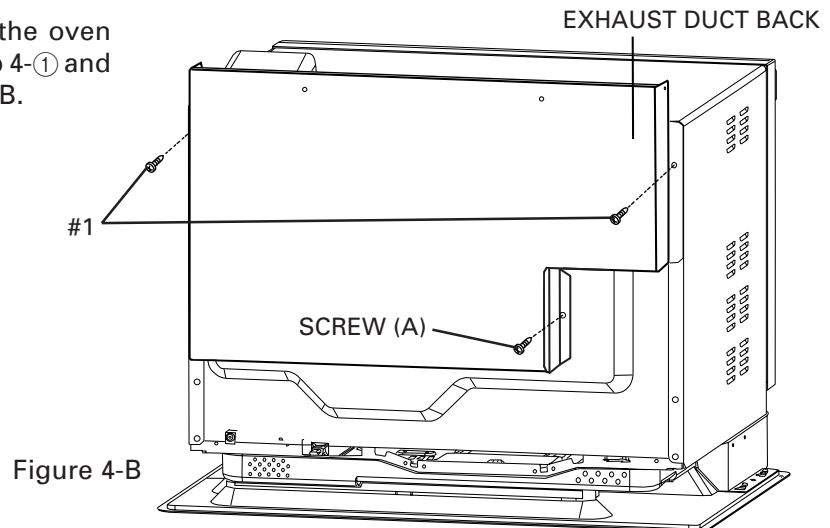

STEP 5: INSTALLATION OF REAR SPACER and EXHAUST DUCT UPPER

- ① Attach RECTIFIER PLATE L to inside of EXHAUST DUCT UPPER with 4 SCREWS (A) as shown in Figure 5-A.
- ② Place EXHAUST DUCT UPPER over the oven and EXHAUST DUCT BACK, and attach REAR SPACER with 2 SCREWS (A) in Figure 5-B.
- ③ Tighten together EXHAUST DUCT UPPER and EXHAUST DUCT BACK at the left and right sides with 2 SCREWS (A) as shown in Figure 5-B.

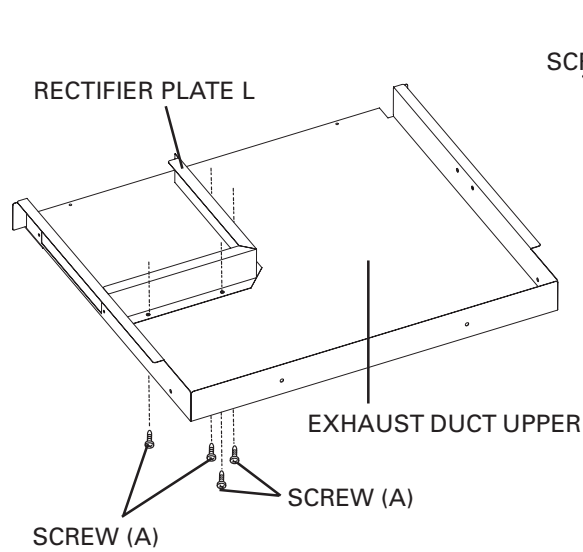

Figure 5-A

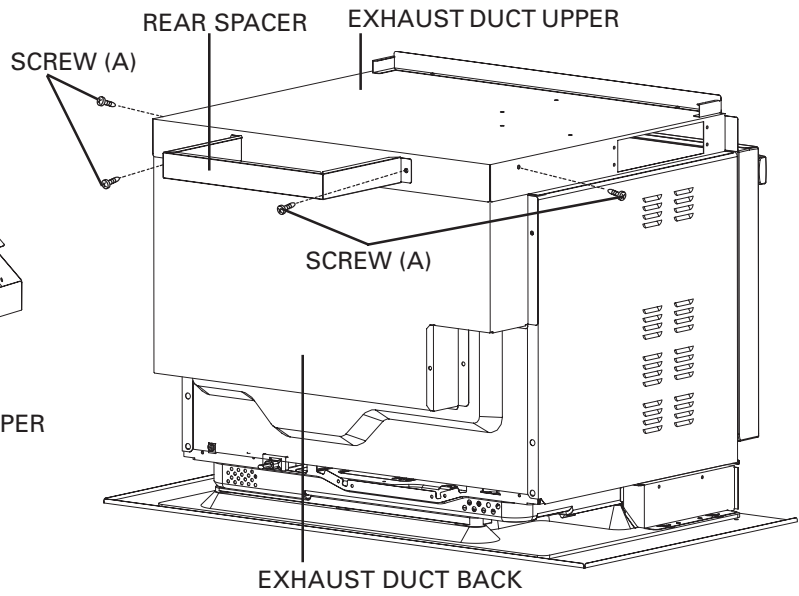

Figure 5-B

STEP 6: INSTALLATION OF EXHAUST DUCT LEFT

- ① Attach EXHAUST DUCT LEFT to the left wall of the oven.
- ② Tighten with 6 screws (A) as shown in Figure 6.

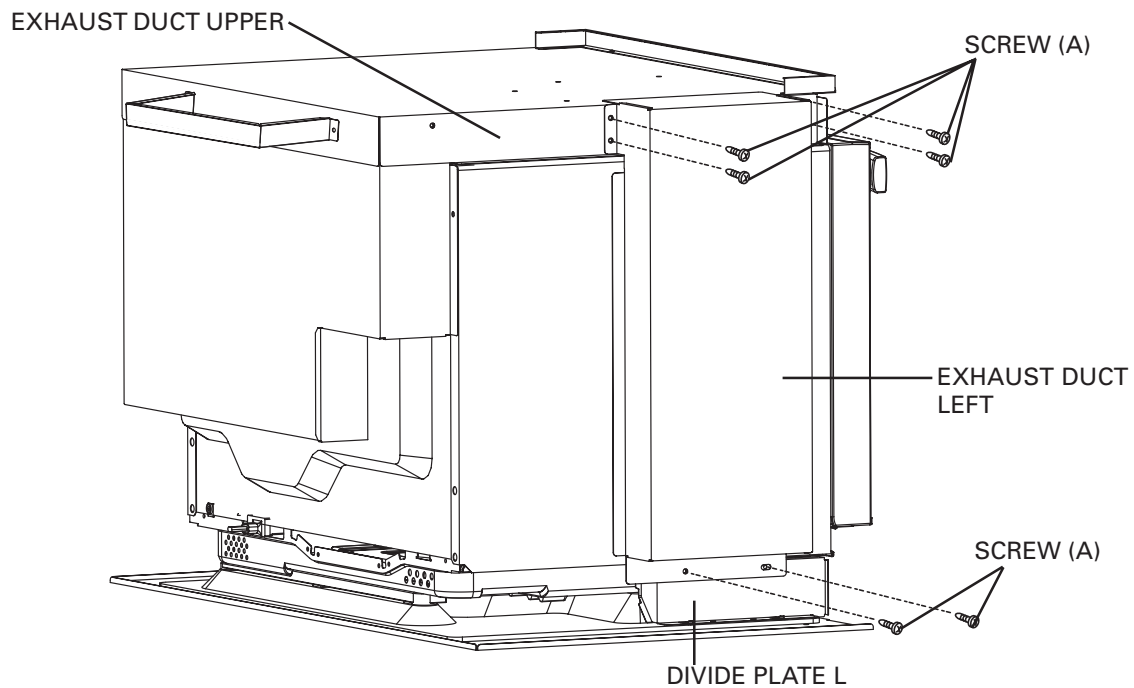

Figure 6

STEP 7: INSTALLATION OF EXHAUST DUCT RIGHT

- ① Attach EXHAUST DUCT RIGHT to the right wall of the oven.
- ② Tighten with 4 SCREWS (A) as shown in the Figure 7.

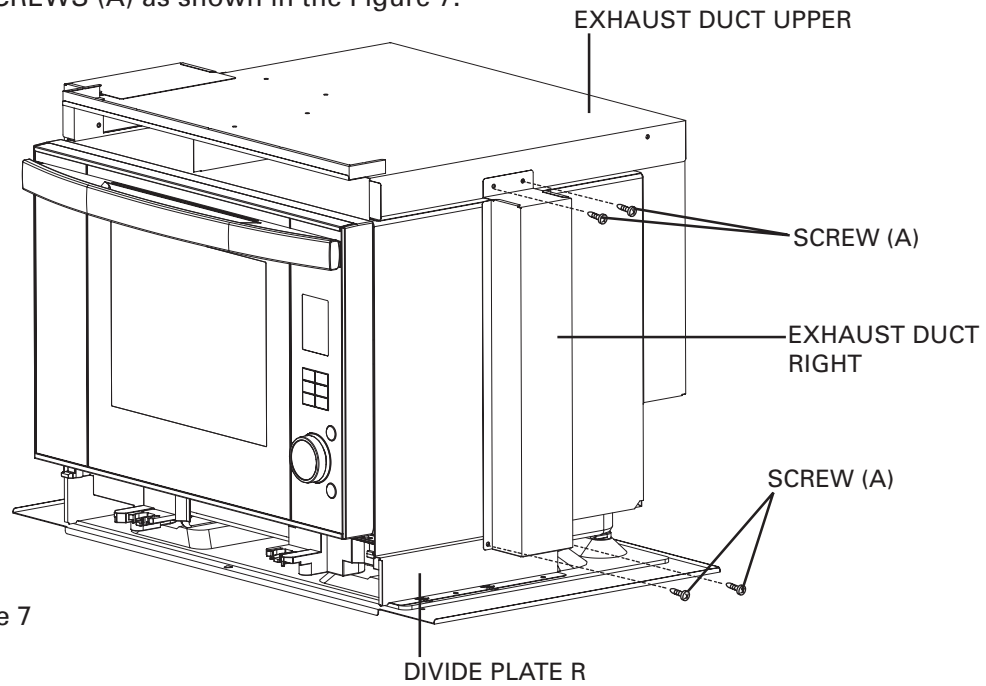

Figure 7

STEP 8: OVEN INSTALLATION

CAUTION: Never hold the handle when moving the oven. Two persons are required to install the oven.

- ① Establish center line of opening and mark front edge.
- ② Place the oven on a table or stand positioned in front of the cabinet where the oven is to be installed. One person should hold the oven while the other connects it to the electrical outlet.
- ③ Install the oven into the shelf with adjusting ▽ mark on EXHAUST DUCT BOTTOM to the center line marked on front edge as shown in Figures 8 and 8-A. Then push the oven until the flange of EXHAUST DUCT BOTTOM touches the edge of the wall or cabinet opening. Avoid pinching the cord between the oven and any wall as shown in Figure 8.

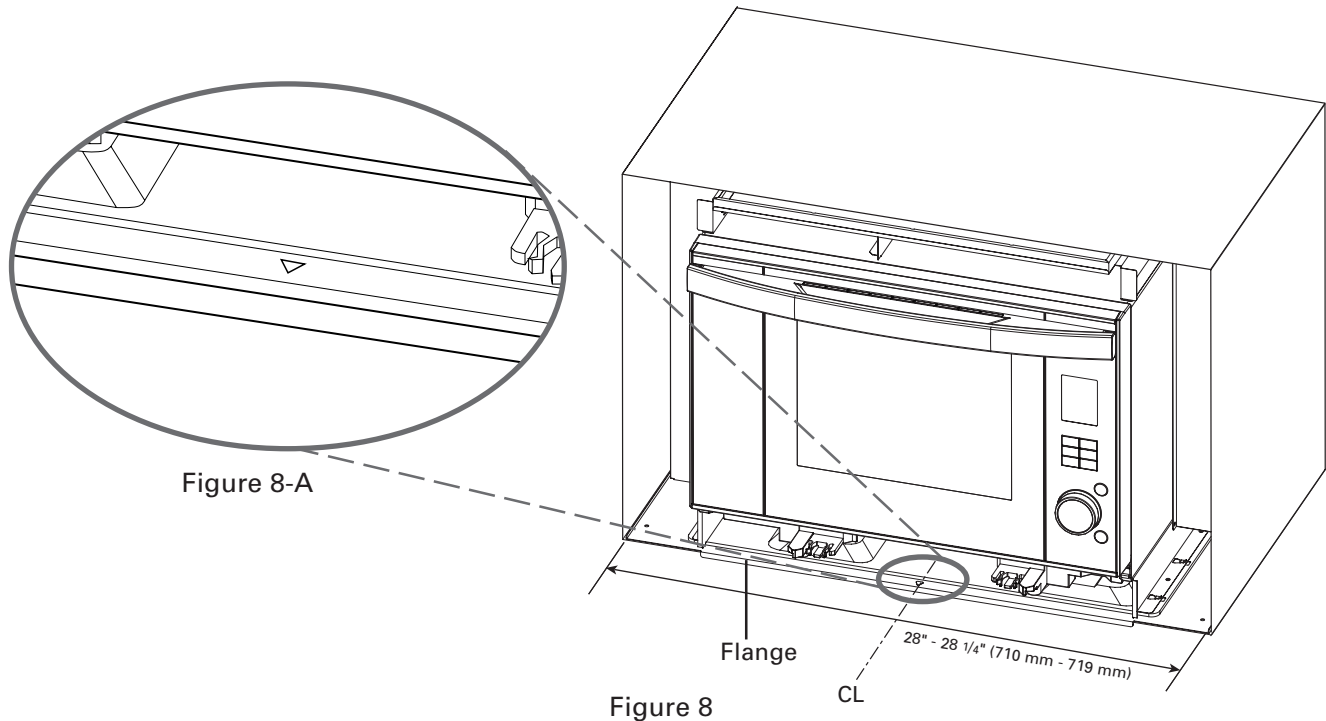

Figure 8

④ Secure EXHAUST DUCT BOTTOM to the shelf with 2 SCREWS (B) as shown in Figures 8-B.

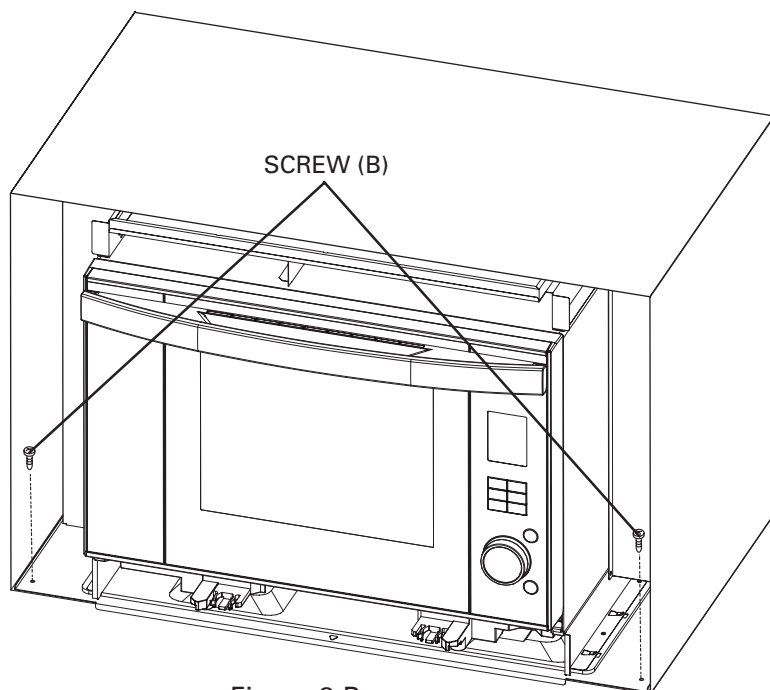
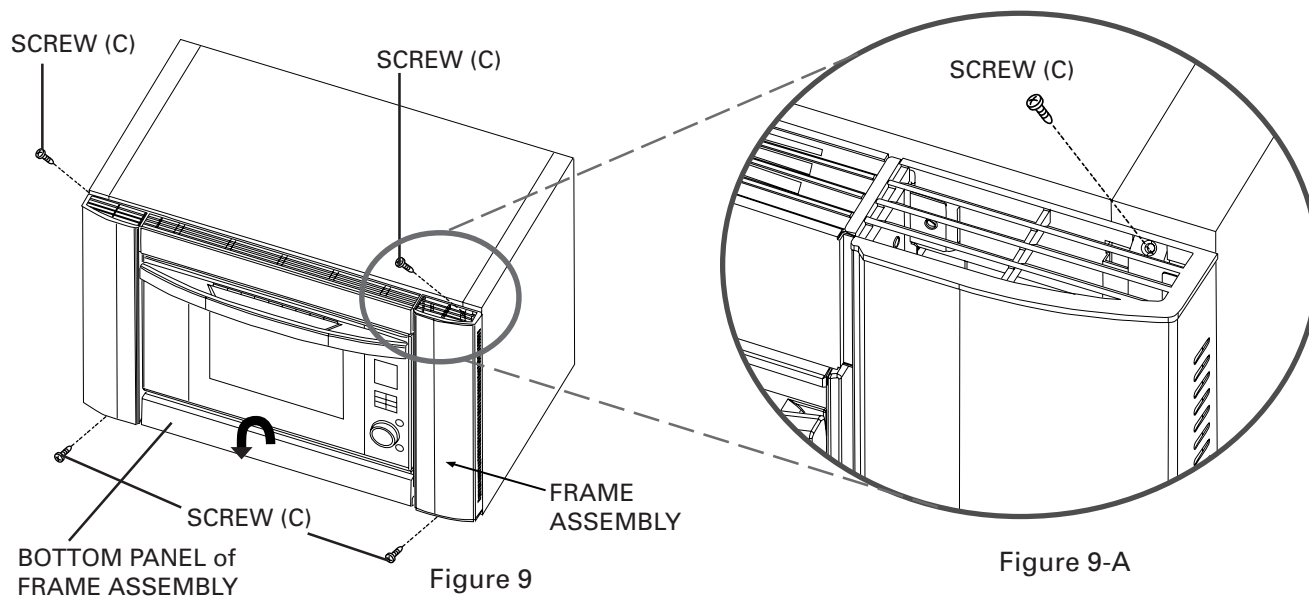

Figure 8-B

STEP 9: FRAME ASSEMBLY INSTALLATION

① Attach FRAME ASSEMBLY and tighten 4 SCREWS (C) as shown in Figure 9 and Figure 9-A.



Pull bottom panel of FRAME ASSEMBLY toward you to remove or replace the drip tray.

For any other assistance or information about this product, please call SHARP's Customer Assistance Center 1-800-BE-SHARP.

SHARP®

SHARP ELECTRONICS CORPORATION
Sharp Plaza, Mahwah, NJ 07495-1163