



# SHARP

## AUDIO TOWER SYSTEM

MODEL

# CD-CH1500

OPERATION MANUAL

Thank you for purchasing this SHARP product.

To obtain the best performance from this product, please read this manual carefully. It will guide you in operating your SHARP product.

CD-CH1500 Audio Tower System consisting of CD-CH1500 (main unit) and CP-RW5500 (speaker system).



COMPACT  
**disc**  
DIGITAL AUDIO





# Special Notes



**CAUTION**  
RISK OF ELECTRIC SHOCK  
DO NOT OPEN



**CAUTION: TO REDUCE THE RISK OF ELECTRIC SHOCK, DO NOT REMOVE COVER (OR BACK). NO USER-SERVICEABLE PARTS INSIDE. REFER SERVICING TO QUALIFIED SERVICE PERSONNEL.**

### Explanation of Graphical Symbols:



The lightning flash with arrowhead symbol, within an equilateral triangle, is intended to alert the user to the presence of uninsulated "dangerous voltage" within the product's enclosure that may be of sufficient magnitude to constitute a risk of electric shock to persons.



The exclamation point within an equilateral triangle is intended to alert the user to the presence of important operating and maintenance (servicing) instructions in the literature accompanying the appliance.

**WARNING: TO REDUCE THE RISK OF FIRE OR ELECTRIC SHOCK, DO NOT EXPOSE THIS APPLIANCE TO RAIN OR MOISTURE.**

**Caution - use of controls or adjustments or performance of procedures other than those specified herein may result in hazardous radiation exposure.**

### NOTE

This equipment has been tested and found to comply with the limits for a Class B digital device, pursuant to Part 15 of the FCC Rules.

These limits are designed to provide reasonable protection against harmful interference in a residential installation.

This equipment generates, uses, and can radiate radio frequency energy and, if not installed and used in accordance with the instructions, may cause harmful interference to radio communications.

However, there is no guarantee that interference will not occur in a particular installation. If this equipment does cause harmful interference to radio or television reception, which can be determined by turning the equipment off and on, the user is encouraged to try to correct the interference by one or more of the following measures:

- Reorient or relocate the receiving antenna.
- Increase the separation between the equipment and receiver.
- Connect the equipment into an outlet on a circuit different from that to which the receiver is connected.
- Consult the dealer or an experienced radio/TV technician for help.

### WARNING

FCC Regulations state that any unauthorized changes or modifications to this equipment not expressly approved by the manufacturer could void the user's authority to operate this equipment.

### NOTE

It is the intent of Sharp that this product be used in full compliance with the copyright laws of the United States and that prior permission be obtained from copyright owners whenever necessary.

### FOR YOUR RECORDS

For your assistance in reporting this unit in case of loss or theft, please record below the model number and serial number which are located on the rear of the unit.

Please retain this information.

**Model number** .....

**Serial number** .....

**Date of purchase** .....

**Place of purchase** .....



# Important Safeguards

## CAUTION

All the safety and operating instructions should be read before the appliance is operated, and should be retained for future reference.

Electrical energy can perform many useful functions. This unit has been engineered and manufactured to assure your personal safety. Improper use can result in potential electrical shock or fire hazards. In order not to defeat the safeguards, observe the following basic rules for its installation, use and servicing.

- 1 Heed Warnings - All warnings on the appliance and in the operating instructions should be adhered to.
- 2 Follow Instructions - All operating and use instructions should be followed.
- 3 Water and Moisture - The appliance should not be used near water - for example, near a bathtub, washbowl, kitchen sink, laundry tub, in a wet basement, or near a swimming pool, etc.
- 4 Carts and Stands - The appliance should be used only with a cart or stand that is recommended by the manufacturer.
  - An appliance and cart combination should be moved with care. Quick stops, excessive force, and uneven surfaces may cause the appliance and cart combination to overturn.
- 5 Wall or Ceiling Mounting - The appliance should be mounted to a wall or ceiling only as recommended by the manufacturer.
- 6 Ventilation - The appliance should be situated so that its location or position does not interfere with its proper ventilation. For example, the appliance should not be situated on a bed, sofa, rug, or similar surface that may block the ventilation openings; or, placed in a built-in installation, such as a bookcase or cabinet that may impede the flow of air through the ventilation openings.
- 7 Heat - The appliance should be situated away from heat sources such as radiators, heat registers, stoves, or other appliances (including amplifiers) that produce heat.
- 8 Power Sources - The appliance should be connected to a power supply only of the type described in the operating instructions or as marked on the appliance.
- 9 Power-Cord Protection - Power-supply cords should be routed so that they are not likely to be walked on or pinched by items placed upon or against them, paying particular attention to cords at plugs, convenience receptacles, and the point where they exit from the appliance.
- 10 Do not use liquid cleaners or aerosol cleaners. Use a damp cloth for cleaning.
- 11 Power Lines - An outdoor antenna should be located away from power lines.



- 12 Outdoor Antenna Grounding - If an outside antenna is connected to the receiver, be sure the antenna system is grounded so as to provide some protection against voltage surges and built-up static charges. Section 810 of the National Electrical Code, ANSI/NFPA No. 70-1984, provides information with respect to proper grounding of the mast and supporting structure, grounding of the lead-in wire to an antenna discharge unit, size of grounding conductors, location of antenna-discharge unit, connection to grounding electrodes, and requirements for the grounding electrode.

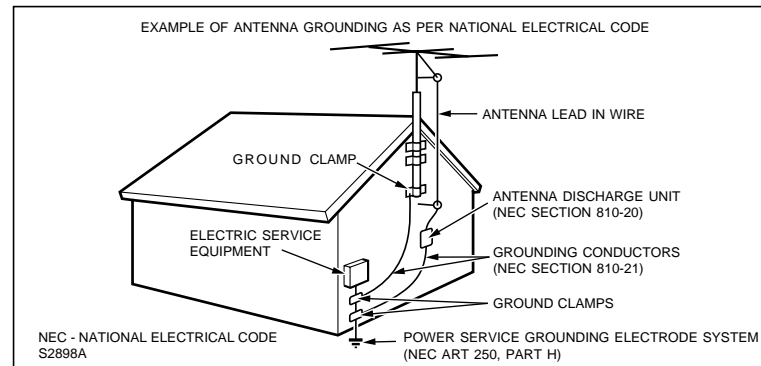

- 13 Nonuse Periods - The power cord of the appliance should be unplugged from the outlet when left unused for a long period of time.
- 14 Object and Liquid Entry - Care should be taken so that objects do not fall and liquids are not spilled into the enclosure through openings.
- 15 Damage Requiring Service - The appliance should be serviced by qualified service personnel when:
  - A The power-supply cord or the plug has been damaged; or
  - B Objects have fallen, or liquid has been spilled into the appliance; or
  - C The appliance has been exposed to rain; or
  - D The appliance does not appear to operate normally or exhibits a marked change in performance; or
  - E The appliance has been dropped, or the enclosure damaged.
- 16 Servicing - The user should not attempt to service the appliance beyond that described in the operating instructions. All other servicing should be referred to qualified service personnel.
- 17 Grounding or Polarization - Precautions should be taken so that the grounding or polarization means of an appliance is not defeated.



# Contents

<b>■ General Information</b>	<b>Page</b>
Accessories .....	4
Precautions .....	5
Controls and Indicators .....	6-9
<b>■ Preparation for Use</b>	
System Connections .....	10-11
Remote Control .....	12
<b>■ Basic Operation</b>	
General Control .....	13
Sound Control .....	14
Setting the Clock .....	15
<b>■ CD Playback</b>	
Listening to a CD (CDs) .....	16-17
<b>■ Advanced CD Playback</b>	
To specify a disc to Play .....	18
Switching the time display .....	18
Repeat or Random Play .....	18
Programmed Play .....	19
<b>■ Radio</b>	
Listening to the Radio .....	20
Listening to the memorized station .....	21
<b>■ Tape Playback</b>	
Listening to a Cassette Tape .....	22
<b>■ Recording</b>	
Recording from a CD .....	23
Recording from the Radio .....	24
<b>■ Advanced Features</b>	
Timer and Sleep Operation .....	25-27
Enhancing Your Stereo System .....	28
<b>■ References</b>	
Troubleshooting Chart .....	29-30
Maintenance .....	30
Specifications .....	31
<b>CONSUMER LIMITED WARRANTY</b> ..... Back cover	

# Accessories

Please confirm that the following accessories are included.

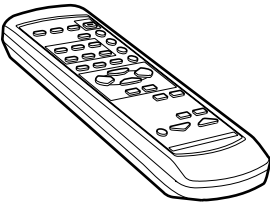
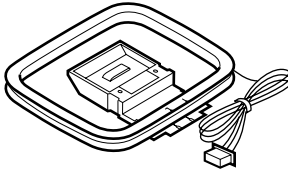
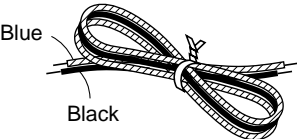
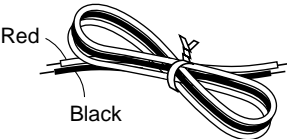
 <p><b>Remote control × 1</b> (RRMCG0245AWSA)</p>	 <p><b>FM/AM loop antenna × 1</b> (QANTL0007AWZZ)</p>
 <p><b>Speaker wire for MAIN terminals × 2</b> (92LD2576BBK)</p>	 <p><b>Speaker wire for SUBWOOFER terminals × 2</b> (92LD2583RB)</p>

**Note:**  
Only the above accessories are included.



# Precautions

## ■ General

- Please ensure that the equipment is positioned in a well-ventilated area and ensure that there is at least 8" (20 cm) of free space along the sides, top and back of the unit.

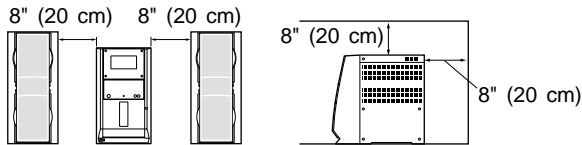

- Use the unit on a firm, level surface free from vibration.
- Keep the unit away from direct sunlight, strong magnetic fields, excessive dust, humidity and electronic/electrical equipment (home computers, facsimiles, etc.) which generates electrical noise.
- Do not place anything on the unit.
- Do not expose the unit to moisture, to temperatures higher than 140°F (60°C) or to extremely low temperatures.
- If your system does not work properly, disconnect the AC power cord from the AC outlet. Plug the AC power cord back in, and then turn on your system.
- In case of an electrical storm, unplug the unit for safety.
- Hold the AC power plug by the head when removing it from the AC outlet, as pulling the cord can damage internal wires.
- **Do not remove the outer cover, as this may result in electric shock. Refer internal service to your local SHARP service facility.**
- This unit should only be used within the range of 41°F - 95°F (5°C - 35°C).

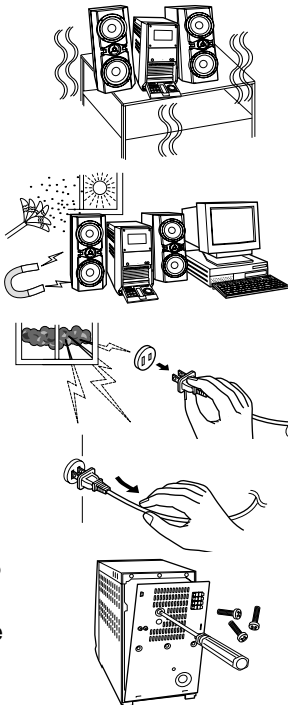

## ■ Volume control

The sound level at a given volume setting depends on speaker efficiency, location and various other factors.

It is advisable to avoid exposure to high volume levels, which occur while turning the unit on with the volume control setting up high, or while continually listening at high volumes.

## ■ Care of compact discs

Compact discs are fairly resistant to damage, however mistracking can occur due to an accumulation of dirt on the disc surface.

Follow the guidelines below for maximum enjoyment from your CD collection and player.

- Do not write on either side of the disc, particularly the non-label side from which signals are read. Do not mark this surface.
- Keep your discs away from direct sunlight, heat, and excessive moisture.
- Always hold the CDs by the edges. Fingerprints, dirt, or water on the CDs can cause noise or mistracking. If a CD is dirty or does not play properly, clean it with a soft, dry cloth, wiping straight out from the center, along the radius.

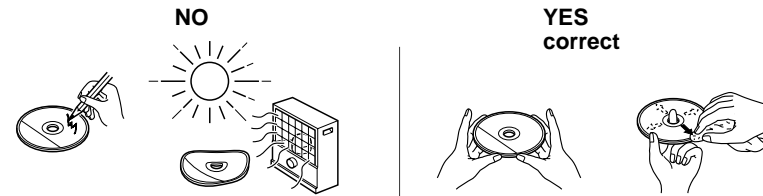

## ■ Cassette tape

- **For playback, use normal or low-noise tapes for the best sound. (Metal or CrO<sub>2</sub> tapes are not recommended.) For recording, use only normal tapes.**
- Do not use C-120 tapes or poor-quality tapes, as they may cause malfunctions.
- Before loading a tape into the cassette compartment, tighten the slack with a pen or pencil.

Cassettes have removable tabs which prevent accidental recording or erasing. Removing the tab will protect the corresponding side. Cover the tab holes with adhesive tape to erase or record again.

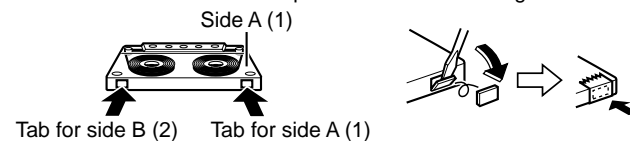



# Controls and Indicators

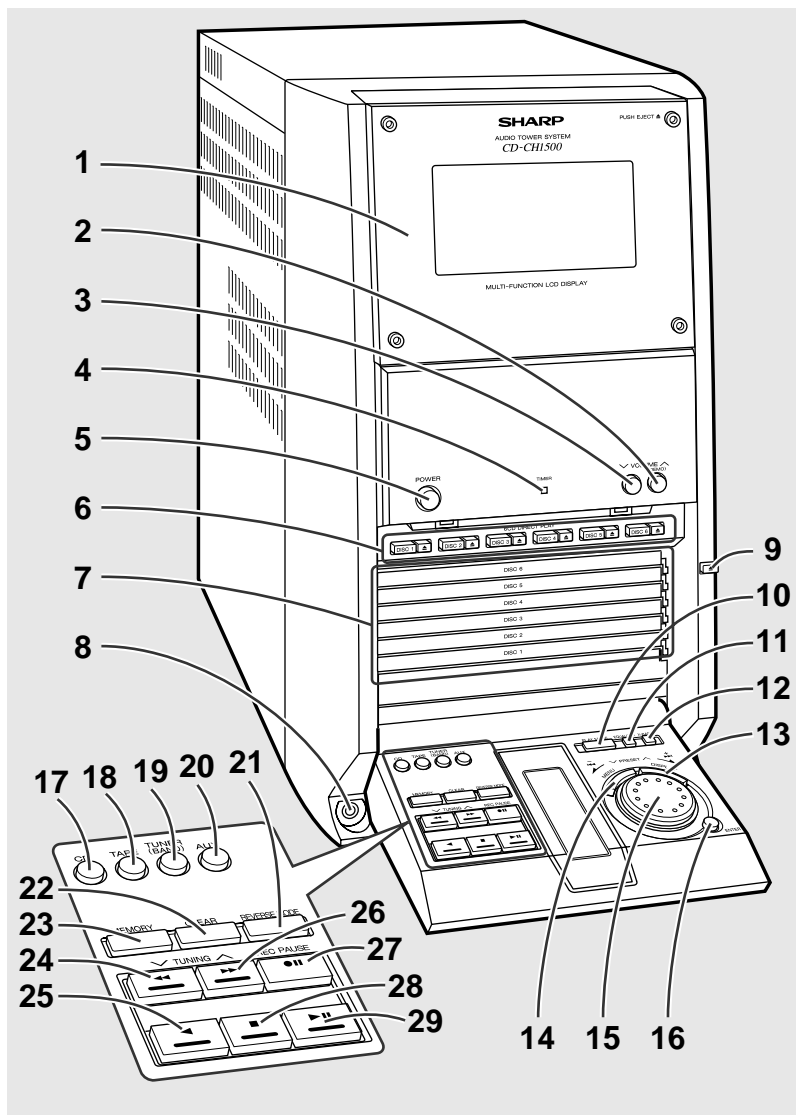

## ■ Front panel

Reference page

1. Cassette Compartment .....	22
2. Volume Up/Demo Button .....	13, 14
3. Volume Down Button .....	14
4. Timer Set Indicator .....	26
5. Power Button .....	13
6. CD Direct Play Buttons (with Indicator)/ CD Eject Buttons .....	16, 18
7. Disc Trays .....	16
8. Headphone Jack .....	28
9. Control Panel Open/Close Button .....	13
10. CD Play Mode Select Button .....	18
11. Equalizer Mode Select Button .....	14
12. Extra Bass Button .....	14
13. Display Button .....	15, 25
14. Menu Button .....	15, 25, 27
15. Jog Dial .....	15, 17, 19, 21, 25, 27
16. Enter Button .....	15, 21, 25, 27
17. CD Button .....	16, 23, 26
18. Tape Button .....	22, 24, 26
19. Tuner (Band) Button .....	20, 26
20. Auxiliary Button .....	28
21. Tape Reverse Mode Select Button .....	22, 24
22. Clear Button .....	19, 21
23. Memory Button .....	19
24. CD Fast Reverse, Tape Fast Wind or Tuning Down Button (with Indicator) .....	17, 20, 22, 28
25. Tape Reverse Play Button (with Indicator) .....	22, 23
26. CD Fast Forward, Tape Fast Wind or Tuning Up Button (with Indicator) .....	17, 20, 22, 28
27. Tape Record Pause Button .....	23, 28
28. Stop Button (with Indicator) .....	17, 22, 23
29. CD Play or Pause, Tape Forward Play Button (with Indicator) .....	17, 22, 23, 24

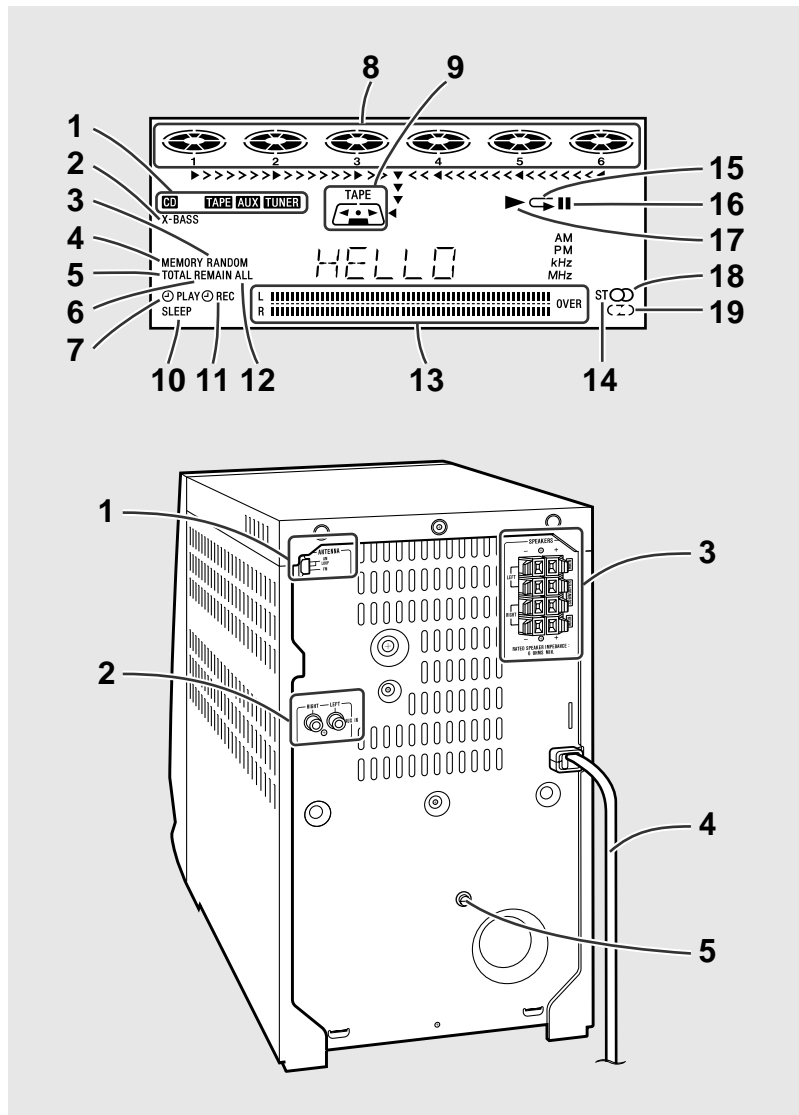

## ■ Multi-function LCD display

1. Function Indicator
2. Extra Bass Indicator
3. Random Play Indicator
4. Memory Indicator
5. Total Indicator
6. Remain Indicator
7. Timer Play Indicator
8. CD Indicators
9. Cassette Indicator
10. Sleep Indicator
11. Timer Recording Indicator
12. All Disc Play Indicator
13. Level Meter
14. FM Stereo Mode Indicator
15. CD Repeat Indicator
16. CD Pause Indicator
17. CD Play Indicator
18. FM Stereo Indicator
19. Tape Reverse Mode Indicator

## ■ Rear panel

Reference page

- |                                |        |
|--------------------------------|--------|
| 1. FM/AM Antenna Jack .....    | 10     |
| 2. Auxiliary Input Jacks ..... | 28     |
| 3. Speaker Terminals .....     | 10     |
| 4. AC Power Cord .....         | 10     |
| 5. Transport screw .....       | 10, 30 |



## Controls and Indicators (continued)

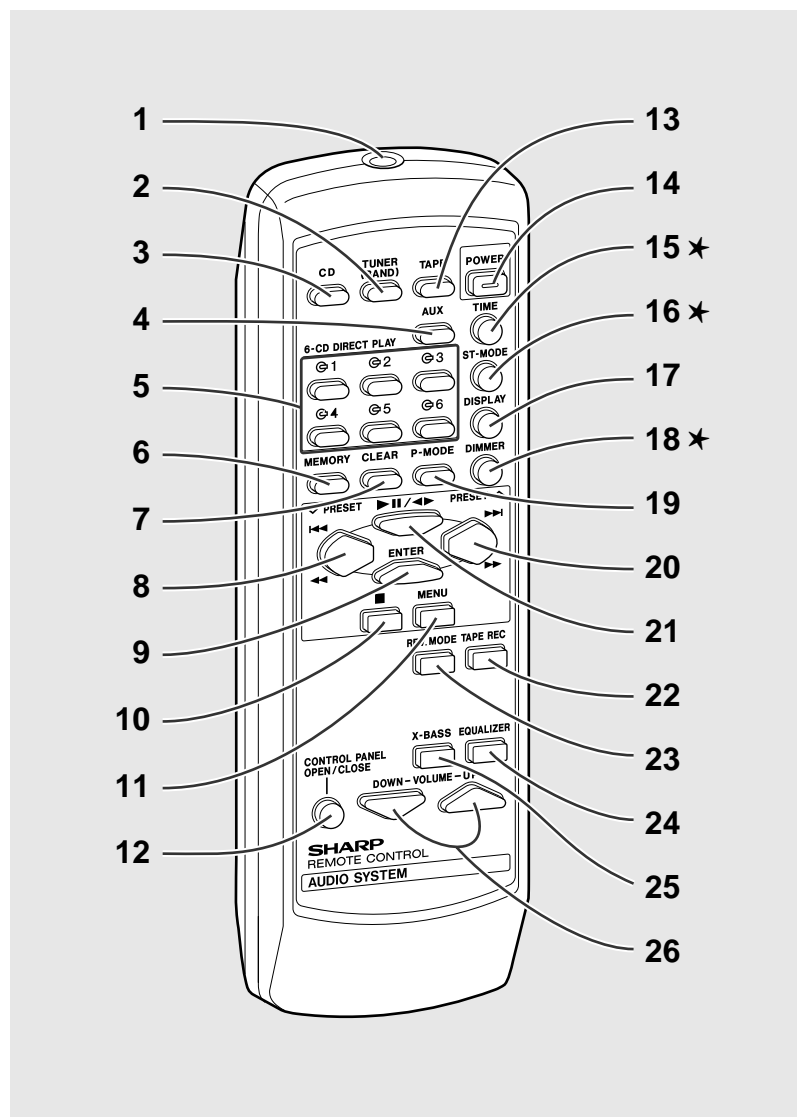

### ■ Remote control

Reference page

- |  |    |
|--|----|
| 1. Remote Control Transmitter .....  | 12 |
| 2. Tuner (Band) Button   |    |
| 3. CD Button   |    |
| 4. Auxiliary Button  |    |
| 5. CD Direct Play Buttons  |    |
| 6. Memory Button   |    |
| 7. Clear Button  |    |
| 8. CD Track Down or Fast Reverse, Tape Fast Wind, Tuner Preset Down Button |    |
| 9. Enter Button  |    |
| 10. Stop Button  |    |
| 11. Menu Button  |    |
| 12. Control Panel Open/Close Button  |    |
| 13. Tape Button  |    |
| 14. Power Button   |    |
| 15. Time Button .....  | 18 |
| 16. FM Stereo Mode Button .....  | 20 |
| 17. Display Button   |    |
| 18. Dimmer Button .....  | 13 |
| 19. CD Play Mode Select Button   |    |
| 20. CD Track Up or Fast Forward, Tape Fast Wind, Tuner Preset Up Button    |    |
| 21. CD Play or Pause, Tape Play Button                                     |    |
| 22. Tape Record Pause Button   |    |
| 23. Tape Reverse Mode Select Button  |    |
| 24. Equalizer Mode Select Button   |    |
| 25. Extra Bass Button  |    |
| 26. Volume Up or Down Buttons  |    |

Buttons with "★" mark in the illustration can be operated on the remote control only.  
Other buttons can be operated both on the main unit and the remote control.





## ■ Speaker system

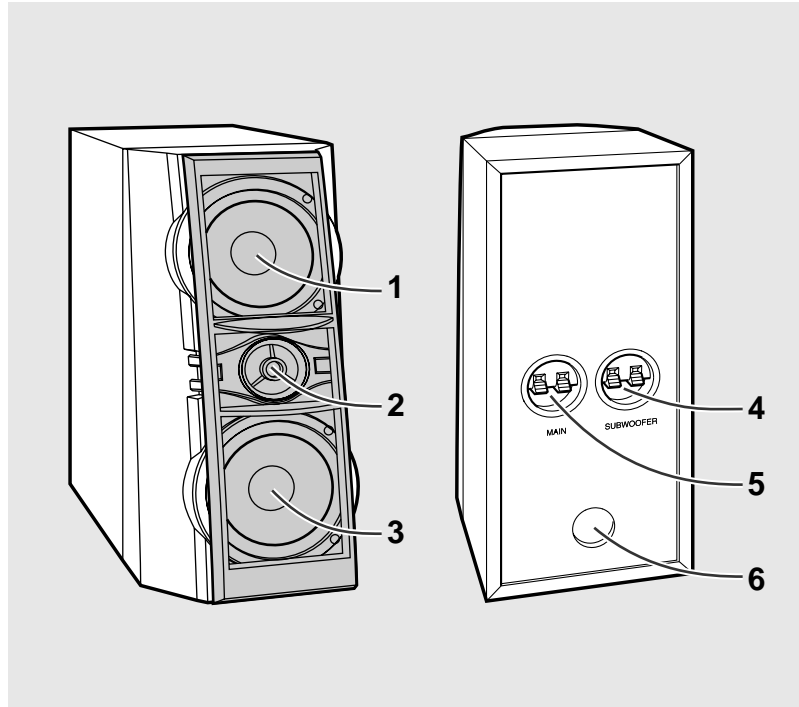

- |              |                           |
|--------------|---------------------------|
| 1. Woofer    | 4. Subwoofer Terminals    |
| 2. Tweeter   | 5. Main Speaker Terminals |
| 3. Subwoofer | 6. Bass Reflex Duct       |

### Speaker grilles are removable:

Make sure nothing comes into contact with the speaker diaphragms when you remove the speaker grilles.

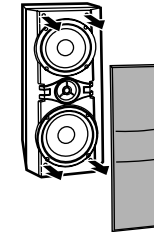

### Placing the speaker system:

There is no distinction between the right and the left speakers.

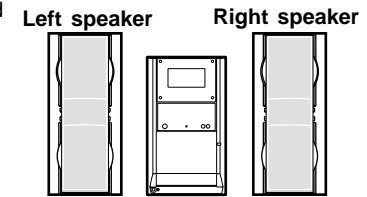

### Bi-amp system:

Each speaker unit has a built-in subwoofer (low frequency range) which is driven separately from the woofer and tweeter (mid-to-high frequency range). Two independent amplifiers which have individual frequency characteristics are used. By amplifying separately the two frequency bands, clearer sound is achieved.

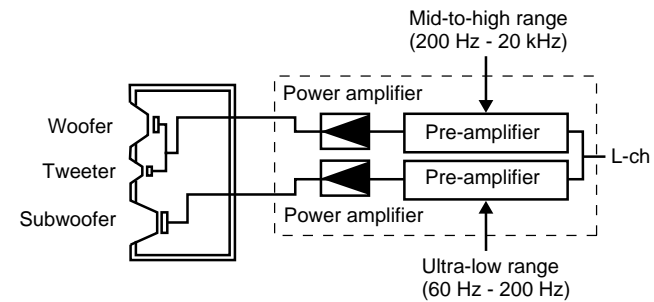



# System Connections

Preparation for Use  
- System Connections -

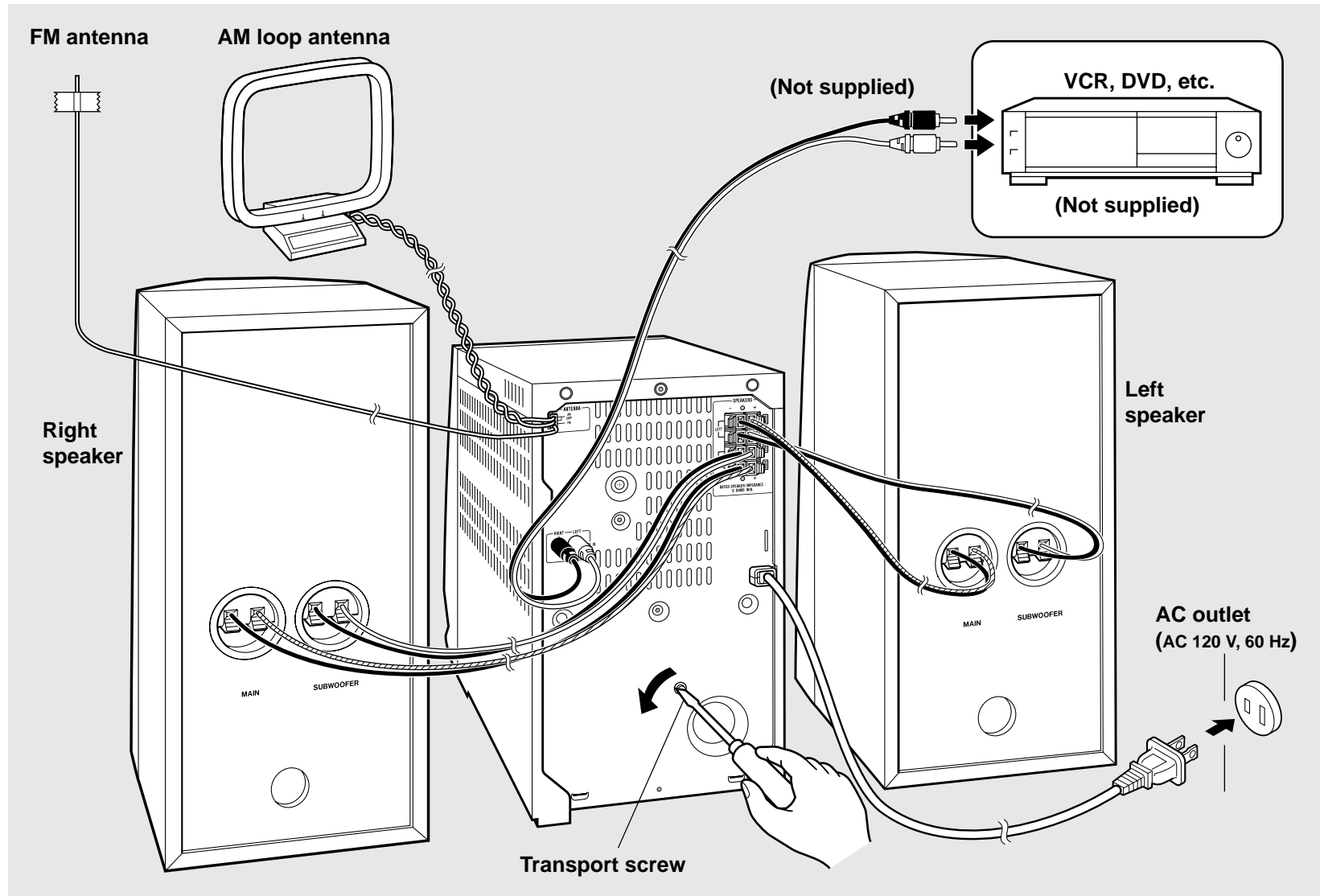



## Remove the transport screw

Before turning the power on, be sure to remove the transport screw on the back of the unit using a flat-blade screwdriver or a coin.

### Note:

This screw is required when transporting the unit again. Please keep it (see page 30).

## Speaker connection

### Main terminals:

Connect the blue wire to the (+) and the black one to the (-).

### Subwoofer terminals:

Connect the red wire to the (+) and the black one to the (-).

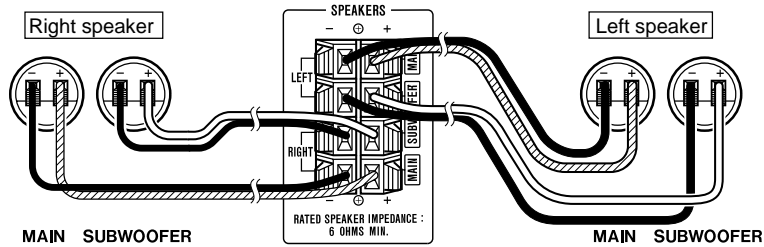

Blue — Black — Red



### Caution:

- Connect the speaker wires to the speakers first, then to the unit.
- Never mistake the MAIN and the SUBWOOFER terminals. The stereo system or the speakers may be damaged.
- Only the included speakers should be used with this product. Do not use other speakers with this unit or use the supplied speakers with other units.
- Do not mistake the right and the left channels. The right speaker is the one on the right side when you face the unit.
- Do not let the bare speaker wires touch each other.

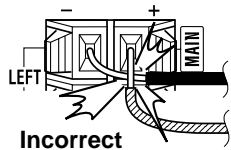

- Do not stand or sit on the speakers. You may be injured.

## FM/AM loop antenna connection

Connect the FM/AM loop antenna to the FM/AM loop antenna jack.

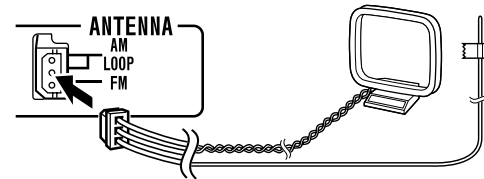

Position the FM antenna wire and rotate the AM loop antenna for optimum reception. Place the AM loop antenna on a shelf, or attach it to a stand or a wall.

### Notes:

- Placing the antenna on the stereo system or near the AC power cord may cause noise pickup. Place the antenna away from the stereo system for better reception.
- Do not connect the attached FM antenna to an outdoor FM antenna. Otherwise, trouble may occur.

### Installing the AM loop antenna:

#### Assembling

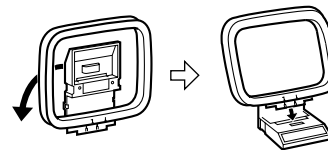

#### Attaching to the wall

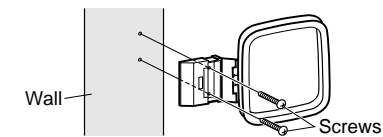

## Connecting the AC power cord

After checking all the connections have been made correctly, plug the AC power cord of this unit into the AC outlet.

If you plug in the unit first, the unit will enter the demonstration mode.

### Note:

Unplug the unit if it will not be used for a prolonged period of time.

■ Demonstration mode (See page 13.)



# Remote Control

## ■ Battery installation

Use 2 "AA" size batteries (UM/SUM-3, R6, HP-7 or similar).  
Batteries are not included.

1. **Remove the battery cover.**
2. **Insert the batteries according to the direction indicated in the battery compartment.**  
When inserting or removing the batteries, push them toward the ⊖ battery terminals.
3. **Replace the cover.**

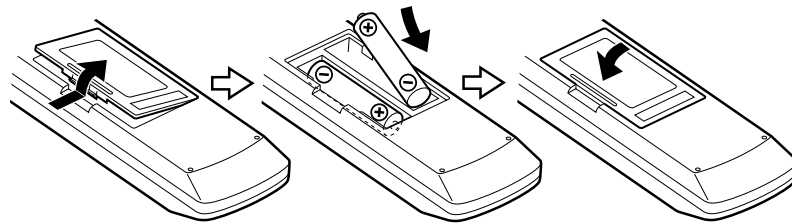

### Precautions for battery use:

- Replace all old batteries with new ones at the same time.
- Do not mix old and new batteries.
- Remove the batteries if the unit will not be used for long periods of time. This will prevent potential damage due to battery leakage.

### Caution:

- Do not use rechargeable batteries (nickel-cadmium battery, etc.).
- Installing the batteries incorrectly may cause the unit to malfunction.

### Notes concerning use:

- Replace the batteries if the operating distance is reduced or if the operation becomes erratic.
- Periodically clean the transmitter on the remote control and the sensor on the stereo system with a soft cloth.
- Exposing the sensor on the stereo system to strong light may interfere with operation. Change the lighting or the direction of the stereo system.
- Keep the remote control away from moisture, heat, shock, and vibrations.

## ■ Test of the remote control

Face the remote control directly to the remote sensor on the unit.

**The remote control can be used within the range shown below:**

Press the POWER button. Does the power turn on? Now, you can enjoy the music.

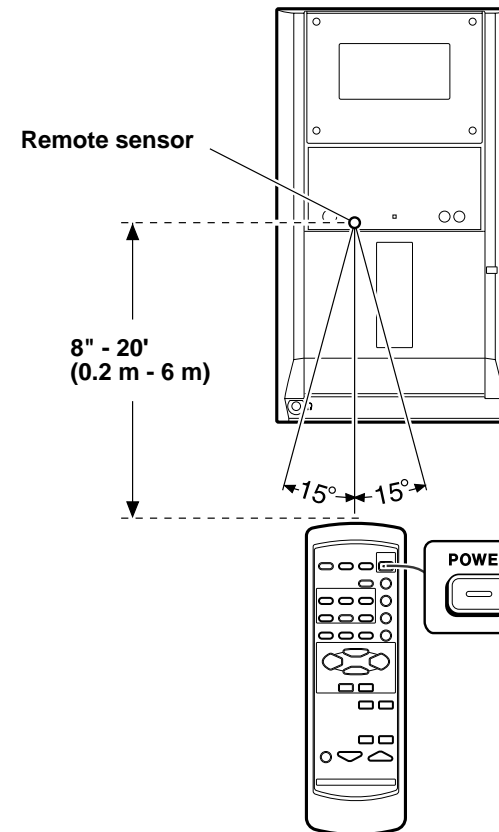



# General Control

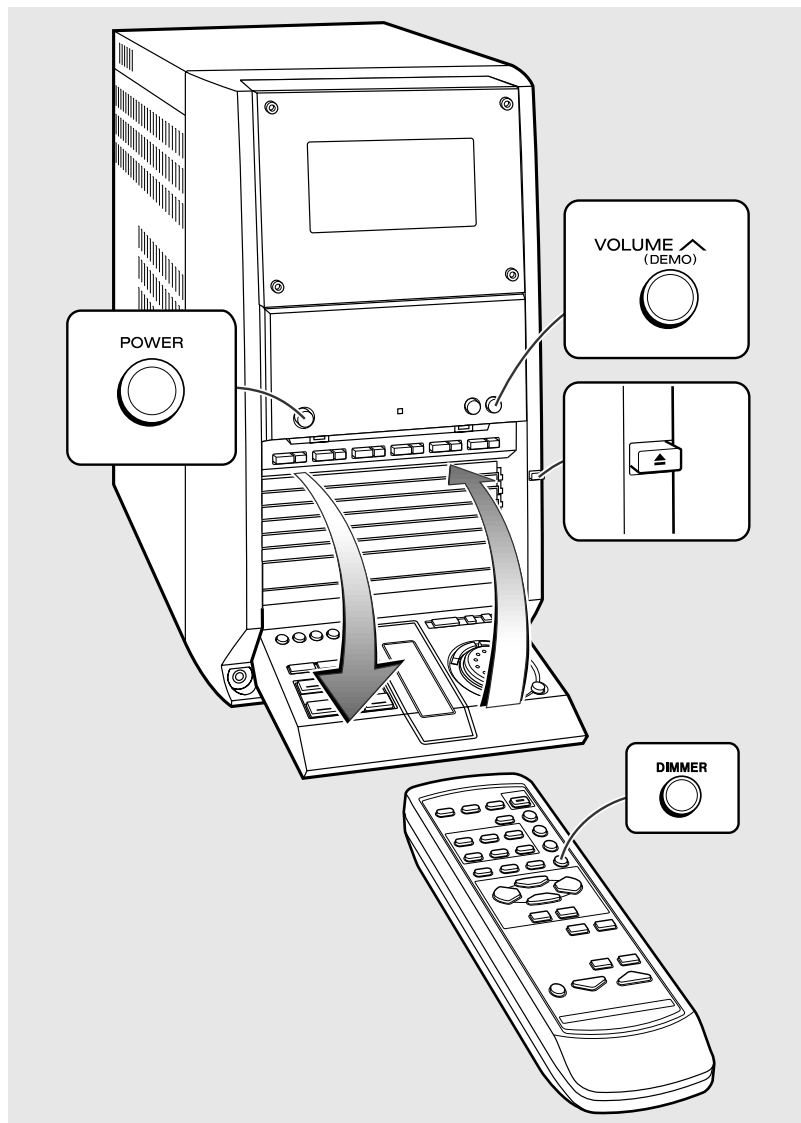

## ■ Demonstration mode

The first time the unit is plugged, the unit will enter the demonstration mode. You will see words scroll.



### To cancel the demonstration mode:

When the unit is in the power stand-by mode (demonstration mode), press the DEMO button. The unit will enter the low power consumption mode.

### To return to the demonstration mode:

When the unit is in the power stand-by mode, press the DEMO button again.

## ■ Opening and closing the control panel

The control panel is motorized. The control panel automatically opens when the power is turned on, and closes when the unit is set to the power stand-by mode.

When the power is turned on, you can open or close the control panel by pressing the control panel open/close ▲ button.

### Caution:

- Do not push the control panel while it is opening or closing.
- Do not press buttons on the control panel strongly. The hinge of the panel may be broken.
- Be careful not to jam your fingers in the control panel.

## ■ Display brightness (2 levels)

You can switch the display brightness by pressing the DIMMER button.

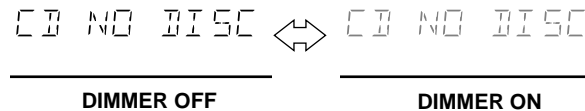



# Sound Control

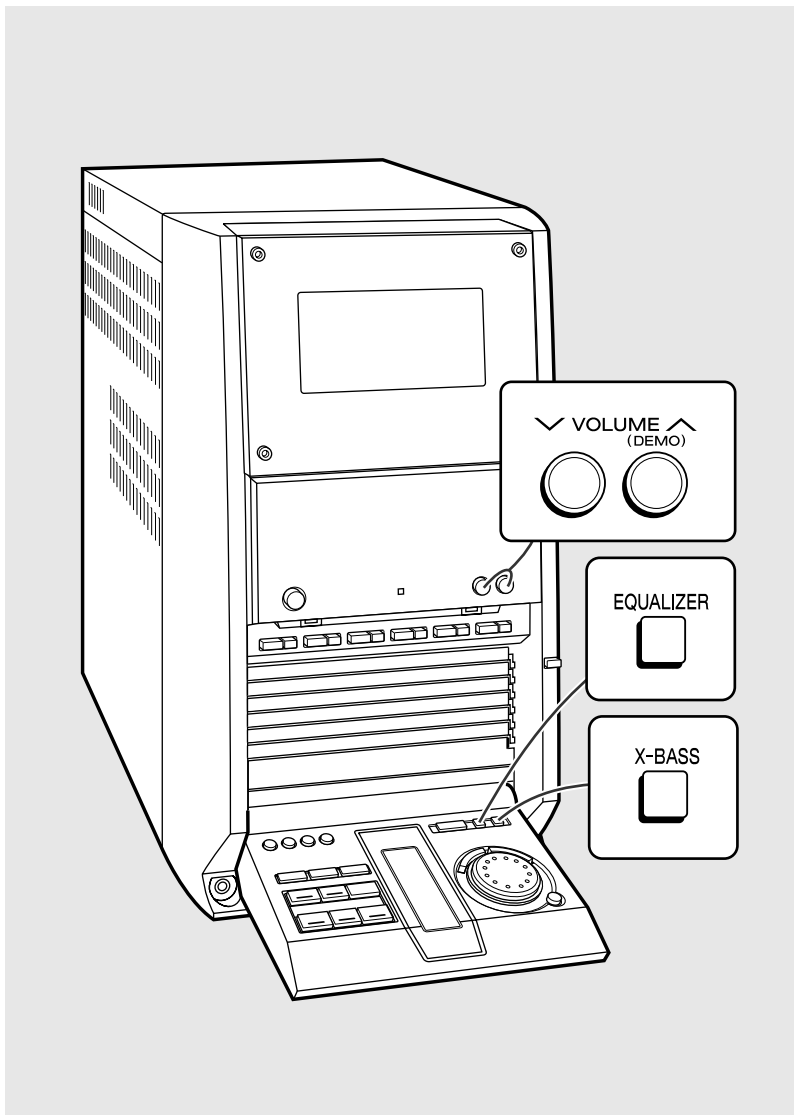

## ■ Volume control

Press the VOLUME  $\wedge$  button to increase the volume and the VOLUME  $\vee$  button for decreasing.

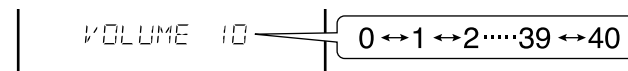

## ■ Bass control

When the X-BASS button is pressed, the unit will enter the extra bass mode which emphasizes the bass frequencies, and "X-BASS" will appear. To cancel the extra bass mode, press the X-BASS button.

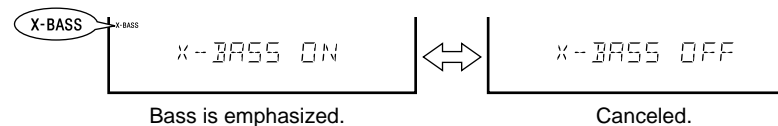

## ■ Equalizer

When the EQUALIZER button is pressed, the current mode setting will be displayed. To change to a different mode, press the EQUALIZER button repeatedly until the desired sound mode appears.

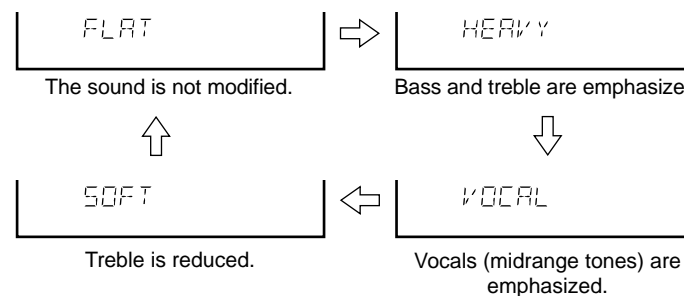



# Setting the Clock

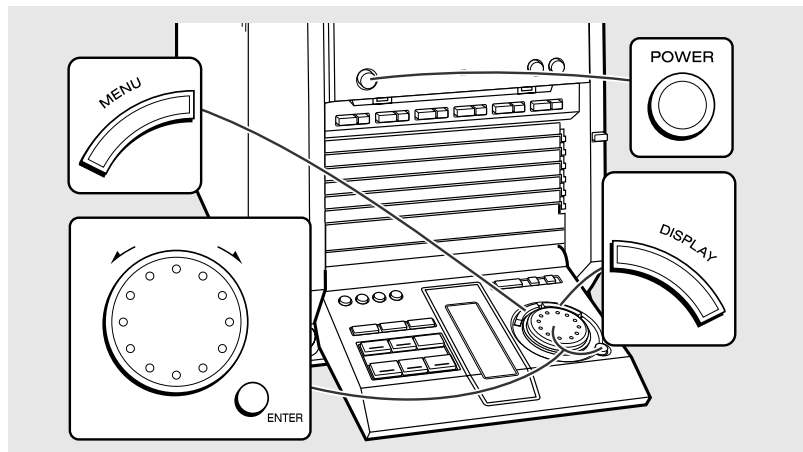

In this example, the clock is set for the 12-hour (AM12:00) display.

**1** Press the **POWER** button to turn the power on.

**2** Press the **MENU** button.

**3** Turn the jog dial to select **"CLOCK"** and within 10 seconds, press the **ENTER** button.

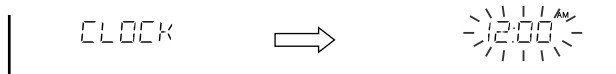

**4** Turn the jog dial to select the 12-hour or 24-hour display and within 2 minutes, press the **ENTER** button.

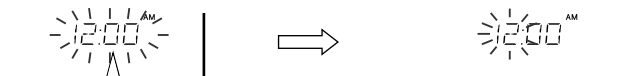

- "AM 12:00" → The 12-hour display will appear. (AM 12:00 - PM 11:59)
- "AM 0:00" → The 12-hour display will appear. (AM 0:00 - PM 11:59)
- "0:00" → The 24-hour display will appear. (0:00 - 23:59)

Note that this can only be set when the unit is first installed or it has been reset.  
[Refer to "Clearing all the memory (reset)" on page 30 for details.]

**5** Turn the jog dial to adjust the hour and within 2 minutes, press the **ENTER** button.

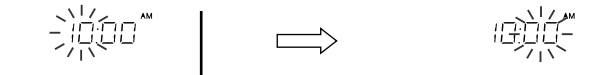

When the 12-hour display is selected, "AM" will change automatically to "PM".

**6** Turn the jog dial to adjust the minutes and within 2 minutes, press the **ENTER** button.

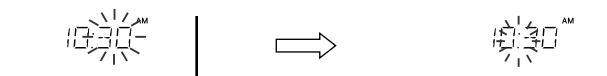

- The hour will not advance even if minutes advance from "59" to "00".
- The clock starts from "0" second. (Seconds are not displayed.)  
The time display will disappear after a few seconds.

## To confirm the time display:

**[When the unit is in the stand-by mode]**

Press the **DISPLAY** button on the remote control.  
The time display will appear for about 3 seconds.



**[When the power is on]**

Press the **MENU** button.  
The time display will appear for about 10 seconds.

## Note:

"CLOCK" will appear or time will flash at the push of the **DISPLAY** button when the AC power supply is restored after a power failure or unplugging the unit.  
Reset the clock as follows.

## To reset the clock:

**[When time is flashing]**

1. Press the **POWER** button.
2. Press the **MENU** button.
3. Press the **ENTER** button.
4. Perform "Setting the Clock" from step 5.

**[When "CLOCK" appears]**

Perform "Setting the Clock" from the beginning.

## To change the 24-hour or 12-hour display:

1. Clear all the programmed contents.  
[Refer to "Clearing all the memory (reset)" on page 30 for details.]
2. Perform "Setting the Clock" from the beginning.



# Listening to a CD (CDs)

This system can play audio CD-R and CD-RW discs just as CD discs, but cannot perform recording.

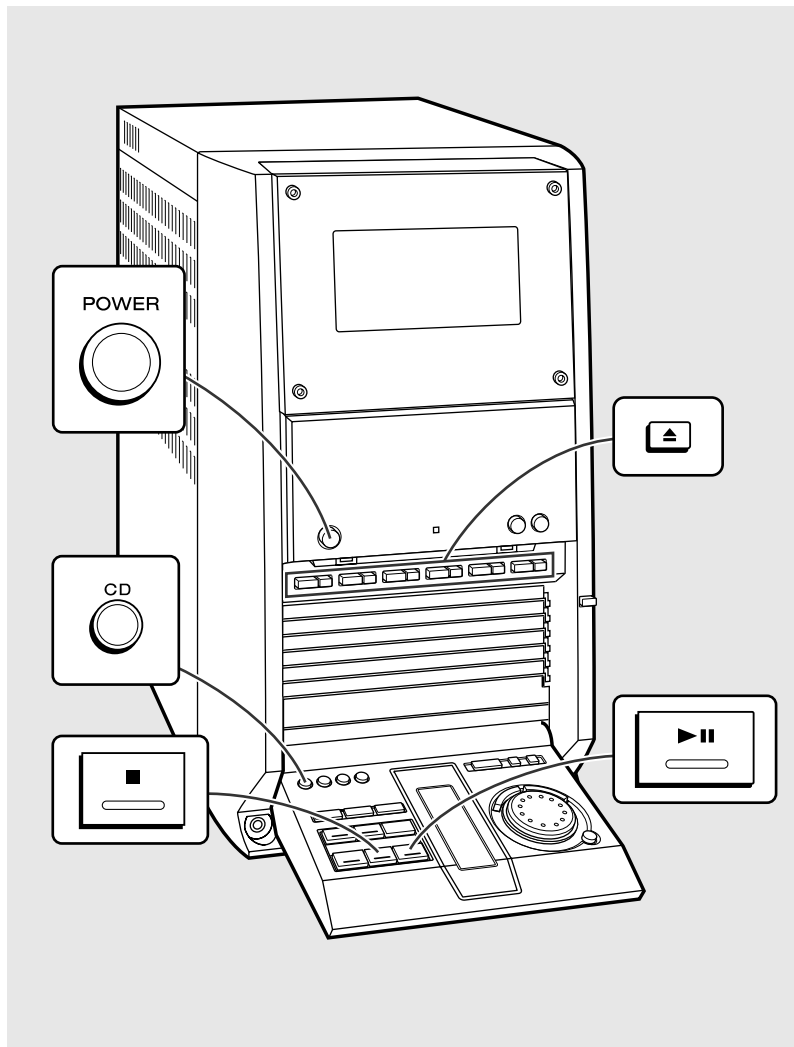

## ■ To play discs in turn (from Disc 1 to Disc 6)

- 1 Press the **POWER** button to turn the power on.
- 2 Press the **CD** button.
- 3 Press the **DISC 1** button to open the disc tray 1.
- 4 Place a **CD on the disc tray 1, label side up.**  
Be sure to place 3" (8 cm) CD in the middle of the disc trays.

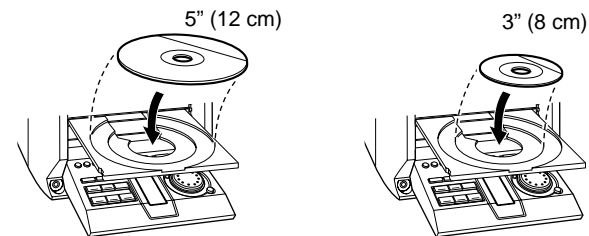

- 5 Press the **DISC 1** button to close the disc tray 1.

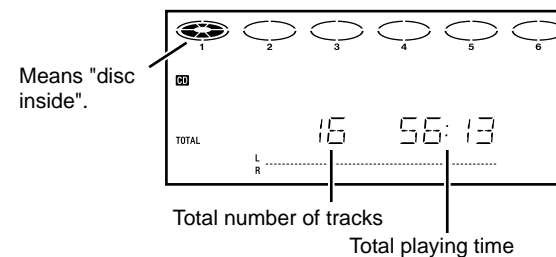

- 6 You can place discs on the trays 2 - 6 by following steps 3 - 5.

**Note:**

The system will search CD trays until it finds a CD and will not search the rest of the trays.





## 7 Press the ►|| button to start playback.

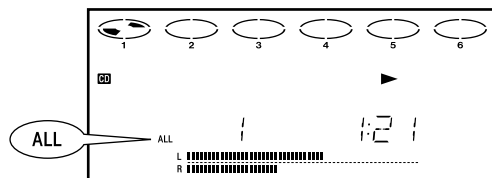

- Playback will begin from track 1 on the DISC 1. After that disc finishes playing, the next disc will automatically start playback.
- When there is no CD in one of the disc tray 1 - 6 positions, that position will be skipped and the next CD will be played.
- When the last track on the DISC 6 has finished playing, the CD player will stop automatically.

### To interrupt playback:

Press the ►|| button.

To resume playback from the same point, press the ►|| button again.

### To stop playback:

Press the ■ button.

### To exchange other CDs while playing a disc:

Press the CD ▲ button for the stopped disc and exchange discs.

### To remove the CDs:

While in the stop mode, press the desired CD ▲ button.

### After use:

Press the POWER button to enter the power stand-by mode.

### Caution:

- Do not place two CDs in one disc tray.
- Do not push the disc tray while it is moving.
- If the power fails while the tray is open, wait until the power is restored.
- If the disc tray is stopped forcibly, "E-CD20" will appear in the display and the unit will not function. If this occurs, press the POWER button to enter the power stand-by mode and then turn the power on again.
- If TV or radio interference occurs during CD operation, move the unit away from the TV or radio.
- If a disc is damaged, dirty, or loaded upside down, the disc will be skipped.

## ■ To locate the beginning of a track

### To move to the beginning of the next track:

Turn the jog dial slowly clockwise by one position during playback.



You can skip to any track by turning the jog dial until the desired track number appears.

### To restart the track being played:

Turn the jog dial slowly counterclockwise by one position during playback.



You can skip to any track by turning the jog dial until the desired track number appears.

### Notes:

- You can locate the beginning of a track on a single disc only.
- The ◀◀ or ▶▶ button on the remote control allows you to locate the beginning of a track.

## ■ To locate the desired portion

### For audible fast forward:

Press and hold down the ►► button during playback.



### For audible fast reverse:

Press and hold down the ◀◀ button during playback.



### Notes:

- Normal playback will resume when the ◀◀ or ►► button is released.
- When the end of the last track is reached during fast forward, "DISC END" will appear on the display and CD operation will be paused. When the beginning of the first track is reached during fast reverse, the disc will start playback automatically.
- You can locate the desired portion on a single disc only.



## To specify a disc to Play

You can play a disc by specifying the disc number.

Press one of the DISC 1 - DISC 6 buttons to play the desired disc.



Selected disc number

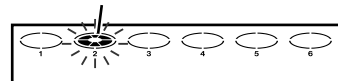

Only the chosen disc will be played and stopped automatically.

### Note:

When one of the DISC 1 - DISC 6 buttons is green, it is ready to play that disc. If there is not a disc on the tray, playback will not begin and the button will turn dark.

### To stop playback:

Press the button.

## Switching the time display

Each time the TIME button on the remote control is pressed during playback or in the pause mode, the display will change.

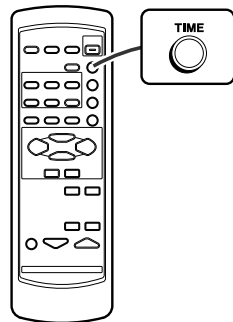

The elapsed playing time for the current track will be displayed.

1 0:21

The remaining playing time for the current track will be displayed.

REMAIN 1 3:12

The total remaining playing time for the disc will be displayed.

TOTAL REMAIN 1 59:12

### Notes:

- During random play, the total remaining playing time will not be displayed.
- Depending on the CD, the playing time display may not match the total playing time which is indicated on the CD jacket, as the time between the tracks is not included.

## Repeat or Random Play

You can select one of the CD playback mode; "Repeat play", "Random play" and "Normal play".

1 Press the PLAY MODE button repeatedly to select the playback mode.

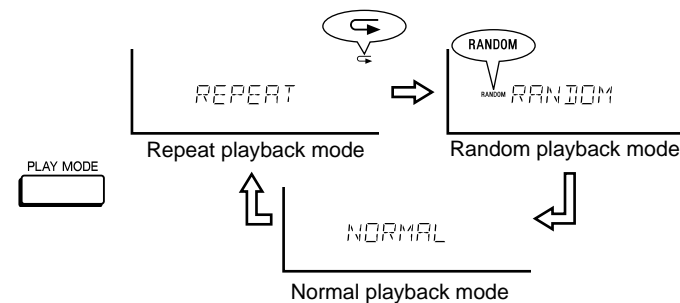

2 Press the or DISC 1 - DISC 6 button to start playback.

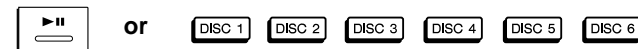

- If playback is started by pressing the button, repeat or random play will be performed on all discs.
- If playback is started by pressing one of the DISC 1 - DISC 6 buttons, repeat or random play will be performed on that disc.

### To repeat a programmed sequence:

Perform steps 1 - 6 in the "Programmed Play" section, select the repeat playback and then press the button.

### Notes:

- After performing repeat or random play, be sure to press the button. Otherwise, the disc(s) will play continuously.
- In random play, the CD player will select and play tracks automatically. (You cannot select the order of the tracks.)

### To cancel repeat and random play:

Press the PLAY MODE button repeatedly to select the normal playback mode.



# Programmed Play

Up to 32 tracks can be programmed.

**1** While in the stop mode, press the MEMORY button to enter the programming save mode.

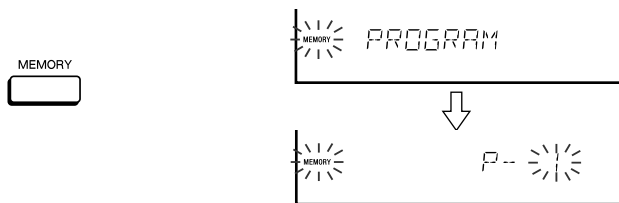

**2** Press one of the DISC 1 - DISC 6 buttons to select the desired disc.

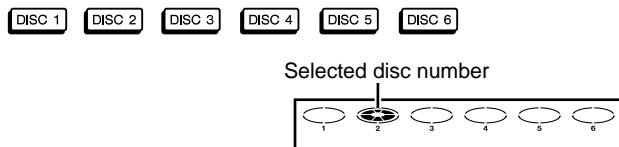

**3** Turn the jog dial to select the desired track.

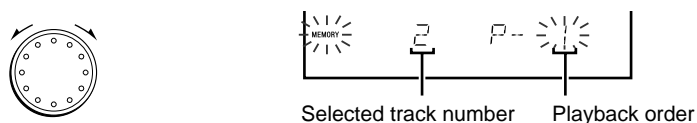

**4** Press the MEMORY button to save the track number.

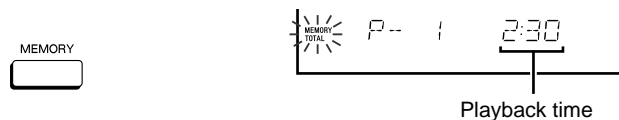

**5** Repeat steps 2 - 4 for other tracks.  
Up to 32 tracks can be programmed.

**6** Press the ■ button.



**7** Press the ►|| button to start playback.



At this time, playback will not begin even if one of the DISC 1 - DISC 6 buttons is pressed.

### To clear the programmed selections:

Press the CLEAR button while the "MEMORY" indicator is flashing. Each time the button is pressed, one track will be cleared, beginning with the last track programmed.

### To cancel the programmed play mode:

While in the stop mode, press the CLEAR button. The "MEMORY" indicator will disappear and all the programmed content will be cleared.

### Adding tracks to the program:

If a program has been previously stored, the "MEMORY" indicator will be displayed. Then follow steps 1 - 6 to add tracks. The new tracks will be stored after the last track of the original program.

### To check which tracks are programmed:

While the unit is stopped in the programmed play mode, press the ◀◀ or ▶▶ button.

### Notes:

- Opening any tray of the programmed discs automatically cancels the programmed sequence.
- Even if you press the POWER button to enter the stand-by mode or change the function from CD to another function, the programmed selections will not be cleared.
- During program operation, random play is not possible.



# Listening to the Radio

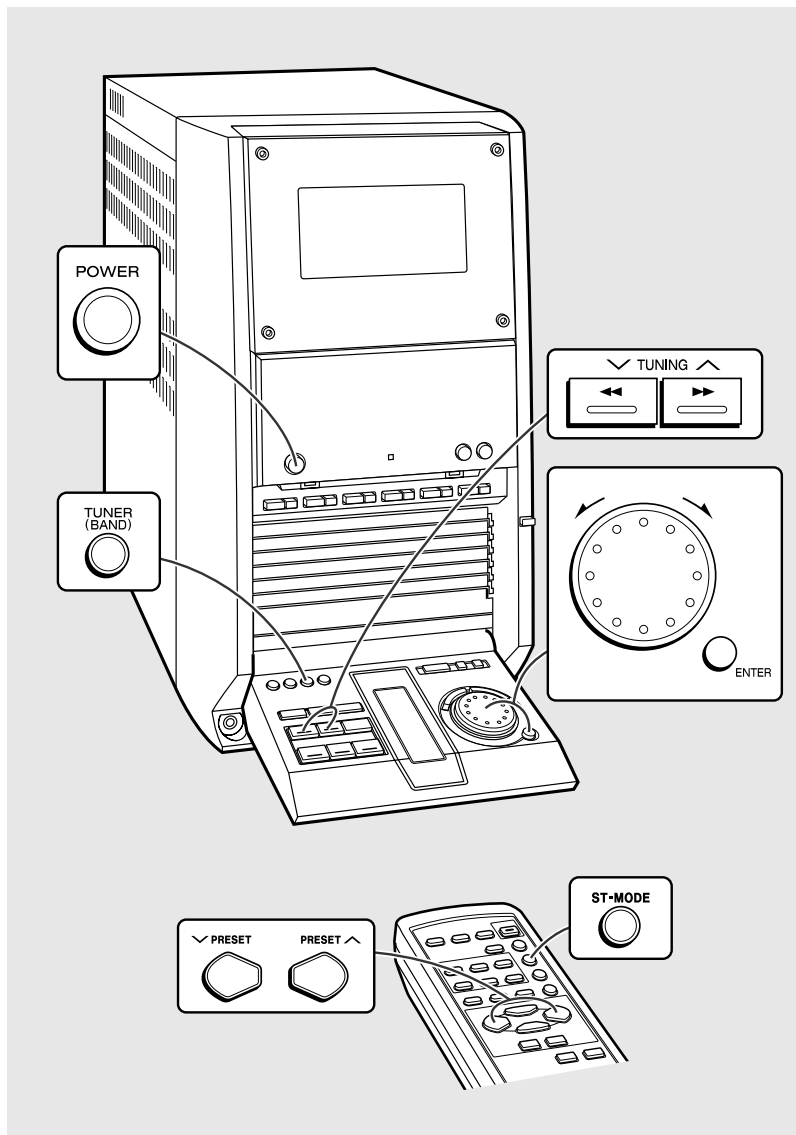

- 1** Press the **POWER** button to turn the power on.
- 2** Press the **TUNER (BAND)** button repeatedly to select the desired frequency band (FM or AM).
- 3** Press the **TUNING** (∨ or ∧) button to tune in to the desired station.

**Manual tuning:**

Press the TUNING (∨ or ∧) button as many times as required to tune in to the desired station.

**Auto tuning:**

When the TUNING (∨ or ∧) button is pressed for more than 0.5 seconds, scanning will start automatically and the tuner will stop at the first receivable broadcast station.

**Notes:**

- When radio interference occurs, auto scan tuning may stop automatically at that point.
- Auto scan tuning will skip weak signal stations.
- To stop the auto tuning, press the TUNING (∨ or ∧) button again.

**To receive an FM stereo transmission:**

Press the ST-MODE button on the remote control to display the “ST” indicator.

- “∞” will appear when an FM broadcast is in stereo.

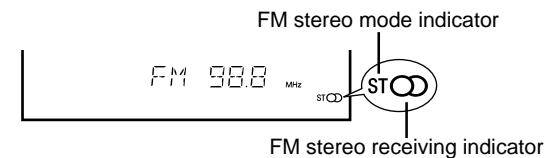

- If the FM reception is weak, press the ST-MODE button. The “ST” indicator goes out. The reception changes to monaural, and the sound becomes clearer.

**After use:**

Press the POWER button to enter the power stand-by mode.





# Listening to the memorized station

## Memorizing a station

You can store 40 AM and FM stations in memory and recall them at the push of a button. (Preset tuning)

**1 Perform steps 1 - 3 in the "Listening to the Radio" section on page 20.**

**2 Press the ENTER button to enter the preset tuning saving mode.**

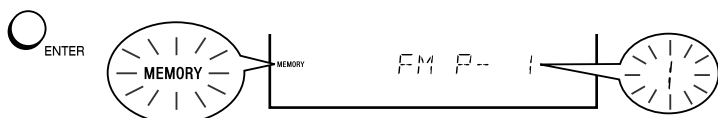

**3 Within 5 seconds, turn the jog dial to select the preset channel number.**

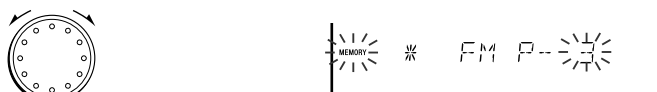

- Store the stations in memory, in order, starting with preset channel 1.
- When "★" is displayed, a station has already been stored in memory.

**4 Within 5 seconds, press the ENTER button to store that station in memory.**

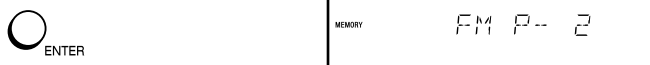

If the "MEMORY" and preset number indicators go out before the station is memorized, repeat the operation from step 2.

**5 Repeat steps 1 - 4 to set other stations, or to change a preset station.**

When a new station is stored in memory, the station previously memorized will be erased.

### Note:

The backup function protects the memorized stations for a few hours should there be a power failure or the AC power cord disconnection.

## To recall a memorized station

**Turn the jog dial to select the desired station.**



This can be operated by pressing the PRESET (∨ or ∧) button on the remote control.

## To scan the preset stations

The stations saved in memory can be scanned automatically. (Preset memory scan)

**1 Press the PRESET (∨ or ∧) button on the remote control for more than 0.5 seconds.**

The preset number will flash and the programmed stations will be tuned in sequentially, for 5 seconds each.

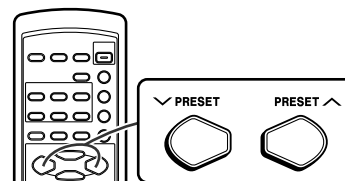

**2 Press the PRESET (∨ or ∧) button again when the desired station is located.**

## To erase all the contents of the preset memory

1. Press the TUNER (BAND) button.
2. Press the ENTER button.
3. Press the CLEAR button.
4. While "ALL CLEAR" is displayed, press the ENTER button.



### To erase only one station:

Recall the memorized station. While it is displayed, press the CLEAR button. While "CLEAR" is displayed, press the ENTER button.



# Listening to a Cassette Tape

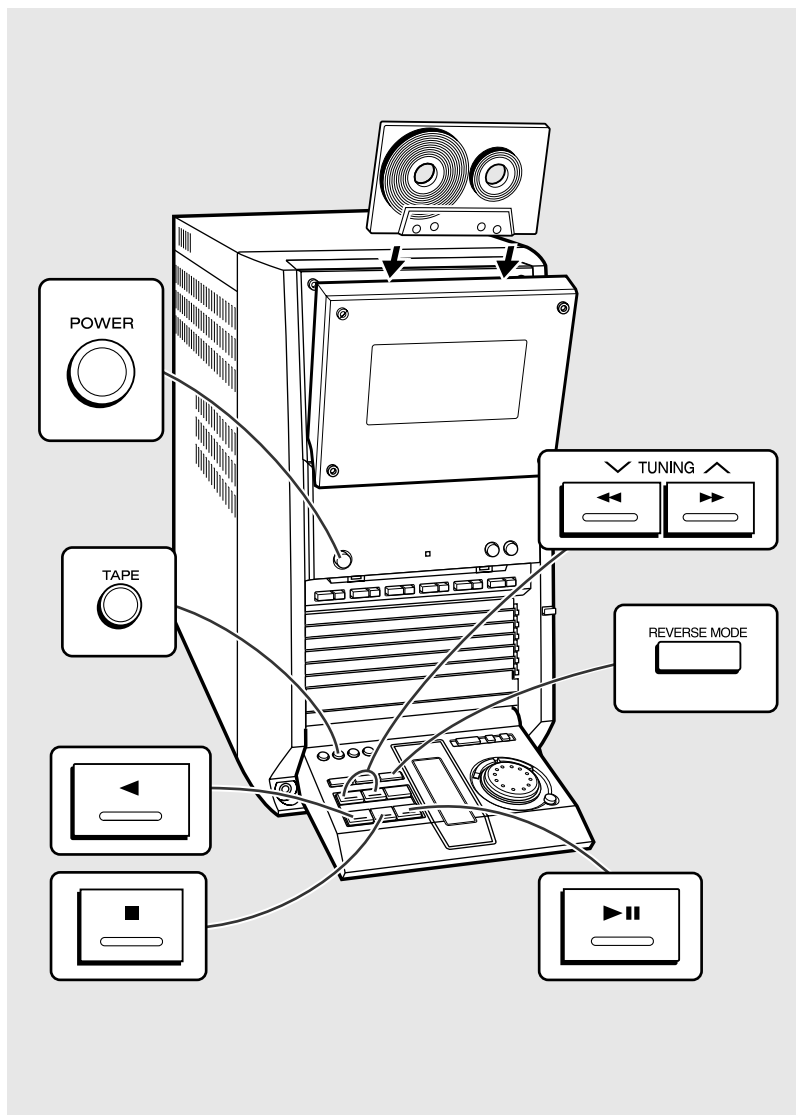

- 1 Press the **POWER** button to turn the power on.
- 2 Press the **TAPE** button.
- 3 Open the cassette door by pushing the area marked "PUSH EJECT ▲".

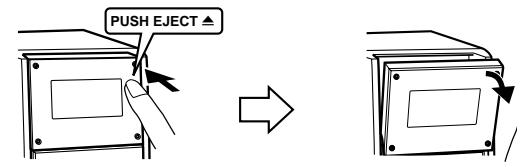

- 4 Load a cassette into the compartment with side A facing you.
- 5 Press the **REVERSE MODE** button to choose one side or both sides.

- ↔ ... To listen to both sides.
- ↔↔ ... For repeat play of both sides.
- ↔ ... To listen to one side.

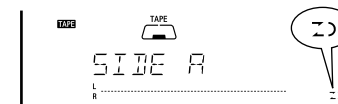

- 6 Press the **▶||** button to listen to side A, or the **◀** button for side B.
  - To play both sides (↔), start from side A. When playback starts from side B, side A will not be played.
  - To play side B using the remote control, press the ■ button to switch the playback side. Then, press the ▶||◀▶ button.

**To stop playback:**  
Press the ■ button.

**Fast forward/rewind on side A:**  
To advance the tape, press the ▶▶ button.  
To rewind it, press the ◀◀ button.

**Fast forward/rewind on side B:**  
To advance the tape, press the ◀◀ button.  
To rewind it, press the ▶▶ button.

**Caution:**

- To remove the cassette, press the ■ button, and then open the compartment.
- If a power failure occurs during tape operation, the tape head will remain engaged with the tape and the cassette door will not open. Wait until the power is restored.
- Even if the ▶|| button is pressed during tape playback, the unit will not enter the pause mode.



# Recording from a CD

- When recording important selections, make a preliminary test to ensure that the desired material is properly recorded.
- SHARP is not liable for damage or loss of your recording arising from malfunction of this unit.
- The volume and sound controls can be adjusted with no effect on the recorded signal (Variable Sound Monitor).
- **Do not use metal or CrO<sub>2</sub> tapes for recording.**

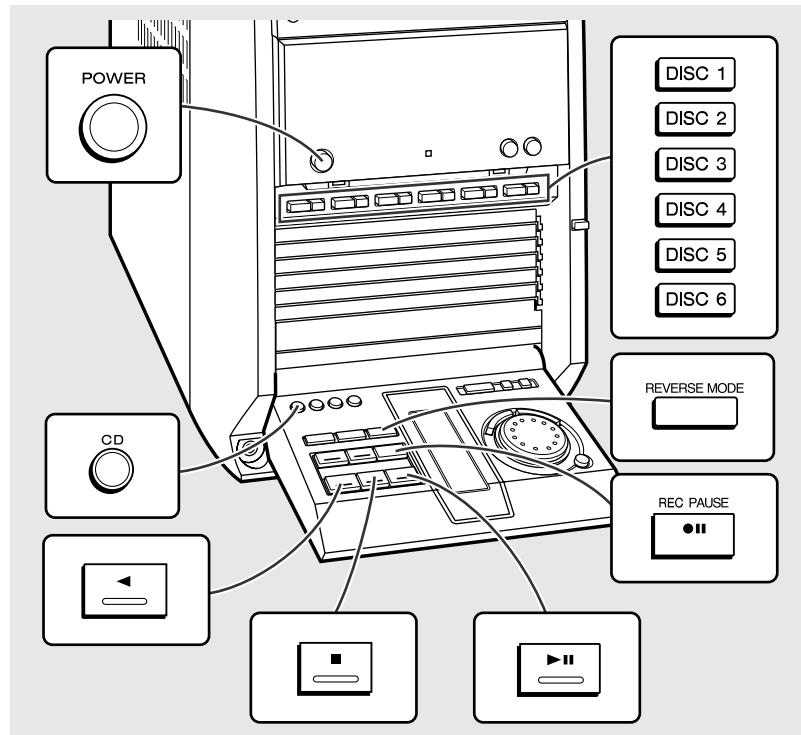

You can record the desired CD using the DISC 1 - DISC 6 buttons.

- 1 Press the POWER button to turn the power on.**
- 2 Press the CD button and load the desired disc.**
- 3 Load a cassette into the compartment with side A facing you.**

## 4 Press the REVERSE MODE button to choose one side or both sides.

- ⏮ ... To record on both sides.
- ⏪ ... To record on only one side.

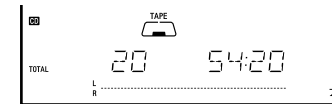

## 5 Press the REC PAUSE button repeatedly to switch to the side you record on.

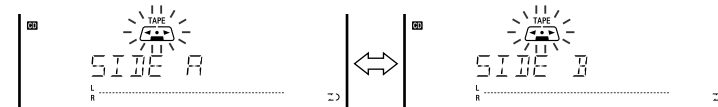

- Recording will be paused.
- To record on both sides, begin on side A. (If recording is started from side B, the tape will not switch over to side A.)

## 6 Press one of the DISC 1 - DISC 6 buttons to start recording.

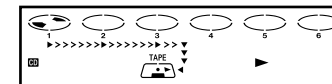

When the CD reaches the end, recording will stop.

### Recording from several CDs continuously:

1. Follow the above steps 1 - 5.
2. Regardless of the setting in step 5, press the ►|| button to record on side A, or the ◀ button for side B.  
Recording will start from the disc of the lowest number.

### To perform programmed recording:

1. Program discs and tracks (page 19).
2. Press the REC PAUSE button.
3. Regardless of the setting in step 5, press the ►|| button to record on side A, or the ◀ button for side B.

### To stop recording:

Press the ■ button.  
The CD and tape will stop.

### Auto restart function:

If the recording side is switched from side A to B during recording, the system will record the interrupted track on side B from its beginning.  
The recording will be made without cutting the beginning of the track on side B.



# Recording from the Radio

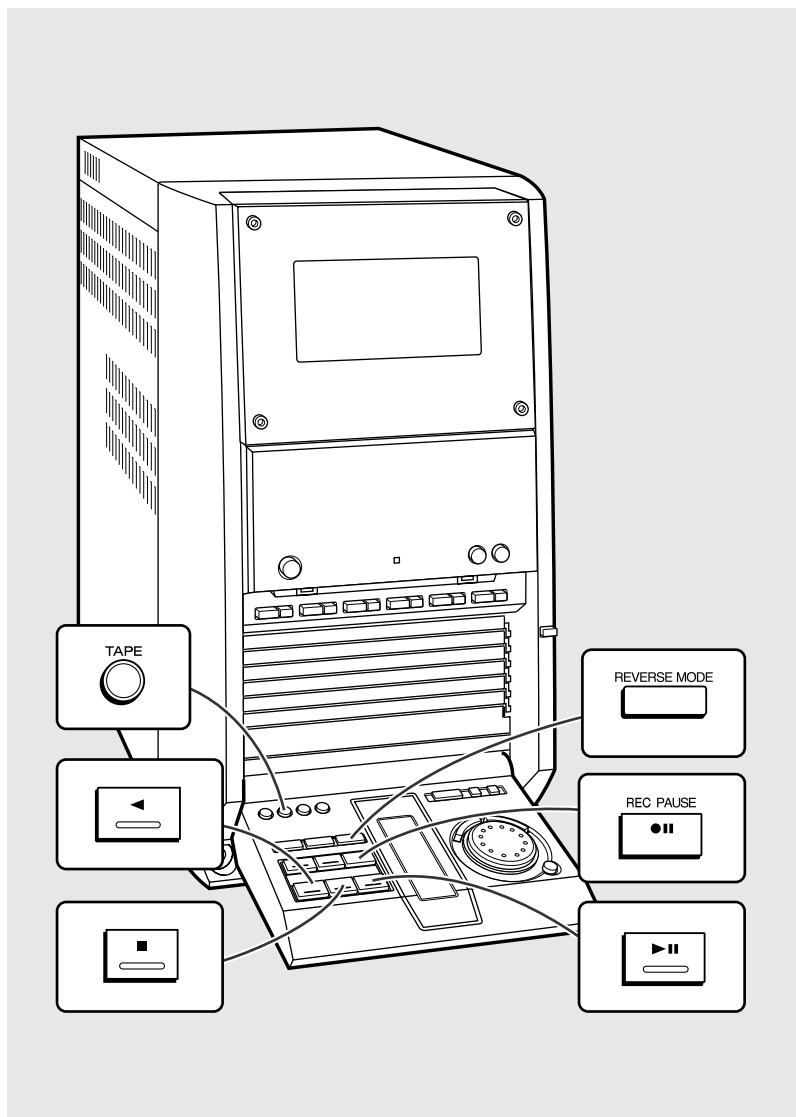

**1** Tune in to the desired station. (See page 20.)

**2** Load a cassette into the compartment with side A facing you.

**3** Press the **REVERSE MODE** button to choose one side or both sides.

- Σ) .... To record on both sides.
- Σ .... To record on only one side.

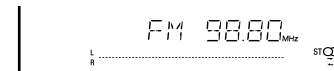

**4** Press the **REC PAUSE** button repeatedly to switch to the side you record on.

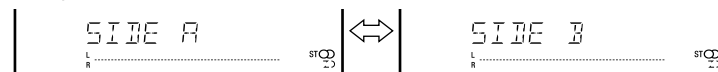

- Recording will be paused.
- To record on both sides, begin on side A. (If recording is started from side B, the tape will not switch over to side A.)

**5** Press the **▶||** button to record on side A, or the **◀** button for side B.

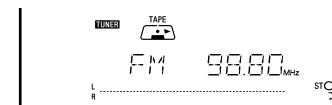

When you press the **▶||/◀▶** button on the remote control, the system will record on the side specified in step 4.

### To interrupt recording:

Press the **REC PAUSE** button.

To resume recording, press the same button (**▶||** or **◀**) you pressed in step 5.

### To stop recording:

Press the **■** button.

### Note:

If you hear a whistling noise while recording an AM station, move the AM loop antenna.

## Erasing recorded tapes

1. Press the **TAPE** button.
2. Follow steps 2 - 5 in "Recording from the Radio".







# Timer and Sleep Operation

## Timer playback:

The unit turns on and plays the desired source (CD, tuner, tape) at the preset time.

## Timer recording:

The unit turns on and starts recording from the tuner at the preset time.

## Sleep operation:

The radio, compact disc and cassette tape can all be turned off automatically.

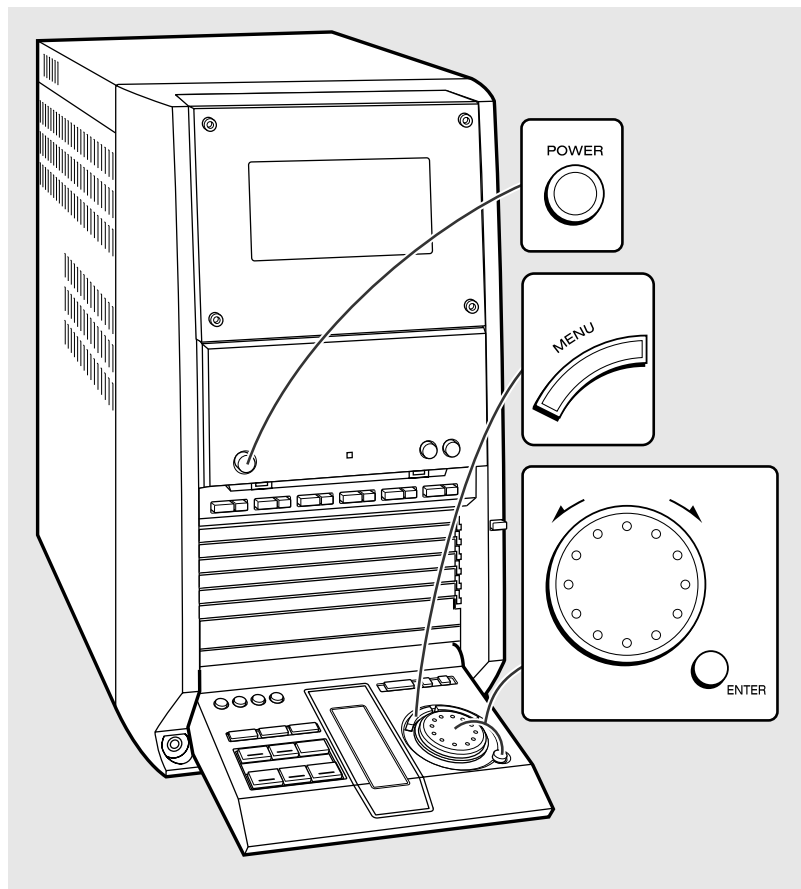

## ■ Timer playback or Timer recording

Before setting the timer:

While the power is in the stand-by mode, press the DISPLAY button on the remote control to check that the clock is on time.



**1** Press the POWER button to turn the power on.

**2** Press the MENU button.

**3** Turn the jog dial to select "TIMER PLAY" or "TIMER REC" mode and within 10 seconds, press the ENTER button.

For timer playback:

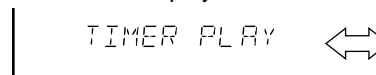

For timer recording:



**4** "⊙ PLAY" or "⊙ REC" will flash for 5 seconds. Press the ENTER button during the flash.

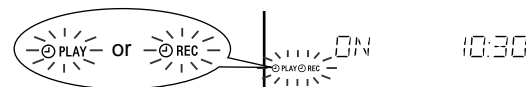

**5** Turn the jog dial to specify the hour to start and within 10 seconds, press the ENTER button.

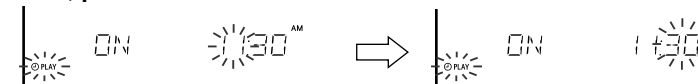

The illustrations show the timer playback setting.

Continued to the next page



## Timer and Sleep Operation (continued)

- 6** Turn the jog dial to specify the minute and within 10 seconds, press the ENTER button.

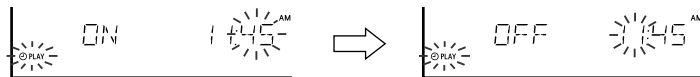

- 7** Turn the jog dial to specify the hour to stop and within 10 seconds, press the ENTER button.

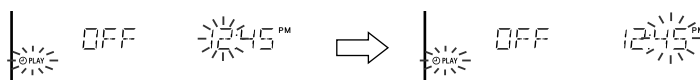

- 8** Turn the jog dial to specify the minute and within 10 seconds, press the ENTER button.

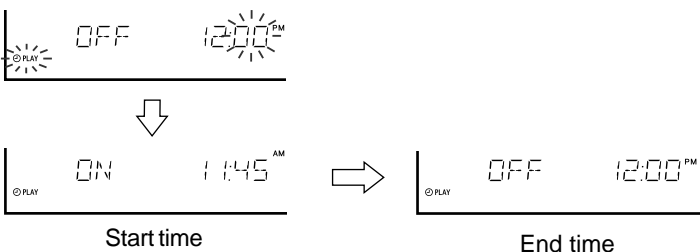

- 9** Adjust the volume using the VOLUME buttons.

Do not turn the volume up too high.

- 10** Press the CD, TUNER (BAND) or TAPE button to select the desired function.

To select the timer playback source : CD, TUNER (BAND) or TAPE.  
To select the timer recording source : TUNER (BAND).

- 11** Press the POWER button to enter the timer stand-by mode.

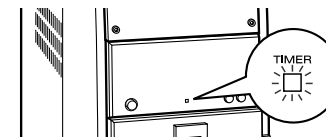

**To cancel the timer playback or timer recording:**

1. Press the POWER button to turn the power on.
2. Press the MENU button.
3. Turn the jog dial to select "TIMER OFF" and then press the ENTER button.

**To check the setting time:**

1. Press the POWER button to turn the power on.
2. Press the MENU button.
3. Turn the jog dial to select "TIMER PLAY" or "TIMER REC" and then press the ENTER button.
4. Press the POWER button to enter the timer stand-by mode.

- 12** When the preset time is reached, playback or recording will start.

The volume will increase gradually until it reaches the volume you were listening to before your system enters the timer stand-by mode.

- 13** When the timer end time is reached, the system will enter the power stand-by mode automatically.

If you press any button during timer operation, the timer mode is canceled and playback or recording will last even when the end time is reached.

**To reset or change the timer setting:**

Perform "Timer playback or Timer recording" from the beginning.

**Notes:**

- Once the time is set, the setting will be retained until a new time is entered.
- When performing timer playback or recording using another unit connected to the AUX IN jacks, select "AUX" in step 10. At this time, only this stereo system will enter the power stand-by mode automatically. (Another unit will not be turned off.)



## ■ Sleep operation

**1** Play back the desired sound source.

**2** Press the MENU button.

**3** Turn the jog dial to select "SLEEP".  
Then press the ENTER button.

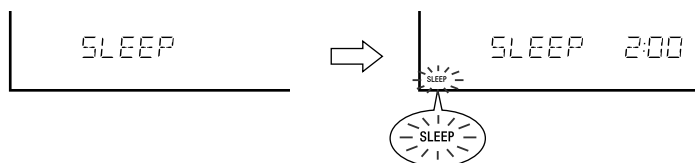

### To change the sleep time:

While the sleep time is displayed, turn the jog dial.  
**(Maximum: 2 hours - Minimum: 30 minutes)**

**4** Press the ENTER button.

**5** Your system will enter the power stand-by mode automatically after the preset time has elapsed.

The volume will be turned down 1 minute before the sleep operation finishes.

### Note:

Once the sleep time is set, it will remain unchanged until the setting is changed.

### To cancel the sleep operation:

Press the POWER button while the sleep timer is set.

### To confirm the remaining sleep time:

Perform the above steps 2 - 3.

This time you can also change the sleep time.

## ■ To use timer and sleep operation together

Example: To fall asleep and wake to the same radio station

You can play back the same source only (the function cannot be switched).

**1** Set the desired playback or recording time (steps 1 - 8, pages 25 - 26).

**2** While playing the desired source, set the sleep time (see left, steps 1 - 4).

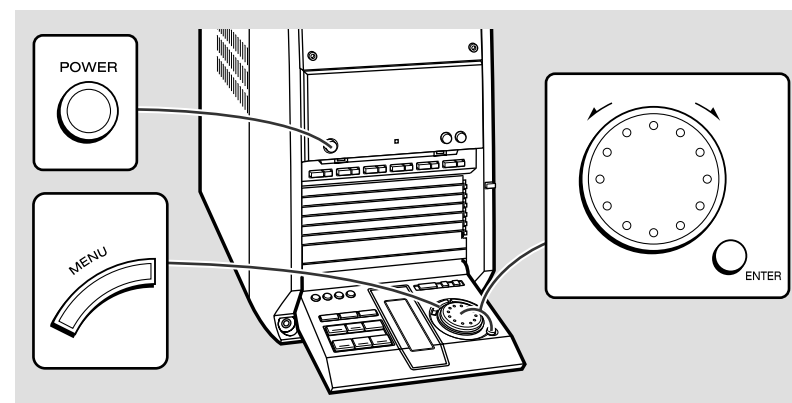
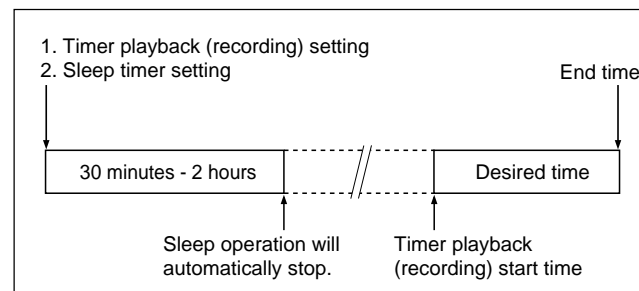



# Enhancing Your Stereo System

The connection cord is not included.  
Purchase a commercially available cord as shown below.

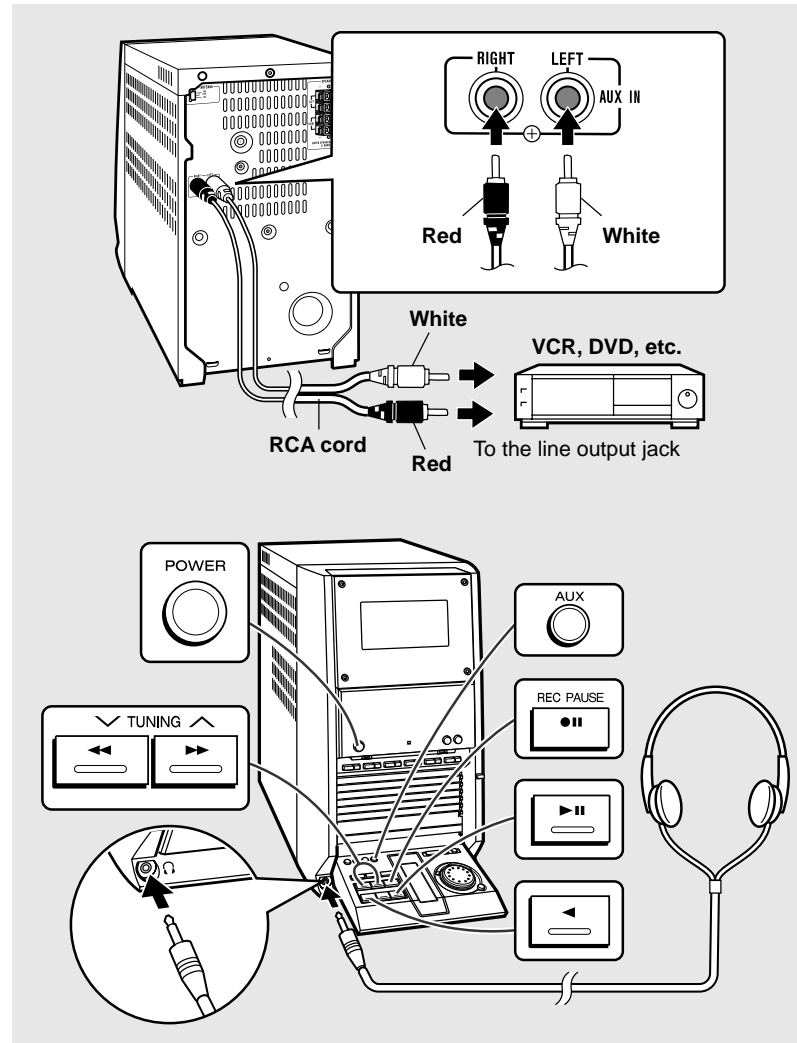

## ■ Listening to the playback sounds from VCR, DVD, etc.

1. Use a connection cable to connect the unit to the AUX IN jacks.  
When using video equipment, connect the audio output to this unit and the video output to a television.
2. Press the POWER button to turn the power on.
3. Press the AUX button to select "AUX".
4. Operate the VCR, DVD, etc.
5. Adjust the input level from VCR, DVD, etc. using the ◀◀ or ▶▶ button.

The "OVER" indicator should not light at the maximum level.

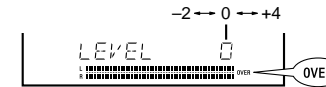

### Note:

To prevent hum interference, place this unit away from a television.

## ■ To record on a tape

1. Insert a cassette in the cassette compartment.
2. Press the AUX button to select "AUX".
3. Press the REC PAUSE button.
4. Operate the VCR, DVD, etc.
5. Adjust the input level from VCR, DVD, etc. using the ◀◀ or ▶▶ button.

The "OVER" indicator should not light at the maximum level.

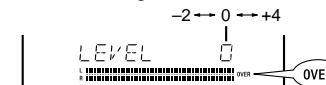

6. Press the ▶▶ button to record on side A, or the ◀ button for side B.

## ■ Headphones

- Before plugging in or unplugging the headphones, reduce the volume.
- Be sure your headphones have a 1/8" (3.5 mm) diameter plug and are between 16 ohms and 50 ohms impedance. The recommended impedance is 32 ohms.
- Plugging in the headphones disconnects the speakers automatically. Adjust the volume using the VOLUME buttons.



# Troubleshooting Chart

Many potential “problems” can be resolved by the owner without calling a service technician.

If something is wrong with this product, check the following before calling your authorized SHARP dealer or service center.

## ■ General

Symptom	Possible cause
<ul style="list-style-type: none"> <li>The clock is not on time.</li> </ul>	<ul style="list-style-type: none"> <li>Did a power failure occur? Reset the clock. (Refer to page 15.)</li> </ul>
<ul style="list-style-type: none"> <li>When a button is pressed, the unit does not respond.</li> </ul>	<ul style="list-style-type: none"> <li>Set this unit to the power stand-by mode and then turn it back on.</li> <li>If the unit still malfunctions, reset it. (Refer to page 30.)</li> </ul>
<ul style="list-style-type: none"> <li>No sound is heard.</li> </ul>	<ul style="list-style-type: none"> <li>Is the volume level set to “0”?</li> <li>Are the headphones connected?</li> <li>Are the speaker wires disconnected?</li> </ul>

## ■ CD player

Symptom	Possible cause
<ul style="list-style-type: none"> <li>Playback does not start.</li> <li>Playback stops in the middle or is not performed properly.</li> </ul>	<ul style="list-style-type: none"> <li>Is the disc loaded upside-down?</li> <li>Does the disc satisfy the standards?</li> <li>Is the disc distorted or scratched?</li> </ul>
<ul style="list-style-type: none"> <li>Playback sounds are skipped, or stopped in the middle of a track.</li> </ul>	<ul style="list-style-type: none"> <li>Is the unit located near excessive vibrations?</li> <li>Is the disc very dirty?</li> <li>Has condensation formed inside the unit?</li> </ul>

## ■ Cassette deck

Symptom	Possible cause
<ul style="list-style-type: none"> <li>Cannot record.</li> </ul>	<ul style="list-style-type: none"> <li>Is the erase-protection tab removed?</li> </ul>
<ul style="list-style-type: none"> <li>Cannot record tracks with proper sound quality.</li> <li>Cannot erase completely.</li> </ul>	<ul style="list-style-type: none"> <li>Is it a normal tape? (You cannot record on a metal or CrO<sub>2</sub> tape.)</li> </ul>
<ul style="list-style-type: none"> <li>Sound skipping.</li> <li>Cannot hear treble.</li> <li>Sound fluctuation.</li> </ul>	<ul style="list-style-type: none"> <li>Is there any slack? Is the tape stretched?</li> <li>Are the capstan, pinch rollers, or heads dirty?</li> </ul>
<ul style="list-style-type: none"> <li>Cannot remove the tape.</li> </ul>	<ul style="list-style-type: none"> <li>If a power failure occurs during playback, the heads remain engaged with the tape. Do not open the compartment forcibly. Wait until electricity resumes.</li> </ul>

## ■ Tuner

Symptom	Possible cause
<ul style="list-style-type: none"> <li>Radio makes unusual noise consecutively.</li> </ul>	<ul style="list-style-type: none"> <li>Is the unit placed near the TV or computer?</li> <li>Is the FM/AM loop antenna placed properly? Move the AC power cord away from the antenna if located near.</li> </ul>

## ■ Remote control

Symptom	Possible cause
<ul style="list-style-type: none"> <li>The remote control does not operate.</li> </ul>	<ul style="list-style-type: none"> <li>Is the AC power cord of the unit plugged in?</li> <li>Is the battery polarity correct?</li> <li>Are the batteries dead?</li> <li>Is the distance or angle incorrect?</li> <li>Does the remote control sensor receive strong light?</li> </ul>

## ■ Condensation

Sudden temperature changes, storage or operation in an extremely humid environment may cause condensation inside the cabinet (CD pickup, tape heads, etc.) or on the transmitter on the remote control.

Condensation can cause the unit to malfunction. If this happens, leave the power on with no disc (or cassette) in the unit until normal playback is possible (about 1 hour). Wipe off any condensation on the transmitter with a soft cloth before operating the unit.

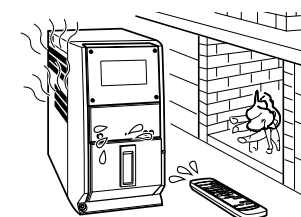



## Troubleshooting Chart (continued)

### ■ If trouble occurs

When this product is subjected to strong external interference (mechanical shock, excessive static electricity, abnormal supply voltage due to lightning, etc.) or if it is operated incorrectly, it may malfunction.

**If such a problem occurs, do the following:**

1. Set the unit to the stand-by mode and turn the power on again.
2. If the unit is not restored in the previous operation, unplug and plug in the unit, and then turn the power on.

### ■ Clearing all the memory (reset)

If neither operation above restores the unit, clear all the memory by following the instructions below.

1. Press the **POWER** button to enter the power stand-by mode.
2. While pressing down the **VOLUME**  $\nabla$  button, press the **POWER** button until "ALL CLEAR" appears.

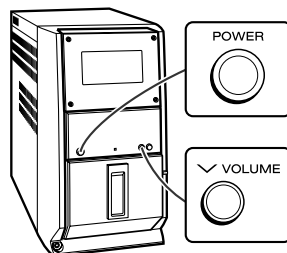

**Caution:**

This operation will erase all data stored in memory including clock, timer settings, tuner preset and CD program.

### ■ Before transporting the unit

On the back of this unit is equipped with a transport safety screw in order to prevent damage during transportation.

1. Press the **POWER** button to turn the power on.
2. Remove all discs from the unit, close the disc tray.  
"CD NO DISC" is displayed.
3. Press the **POWER** button to enter the stand-by mode.  
"GOOD-BYE" is displayed.
4. When "GOOD-BYE" disappears, unplug the AC power cord from the AC outlet.
5. Insert the transport safety screw into the back of the unit and tighten it with a flat-blade screwdriver.

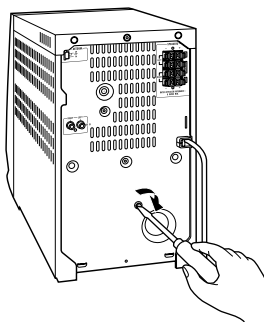

## Maintenance

### ■ Cleaning the tape-handling parts

- Dirty heads, capstans or pinch rollers can cause poor sound and tape jams. Clean these parts with a cotton swab moistened with commercial head/pinch roller cleaner or isopropyl alcohol.
- When cleaning the heads, pinch rollers, etc., unplug the unit which contains high voltages.

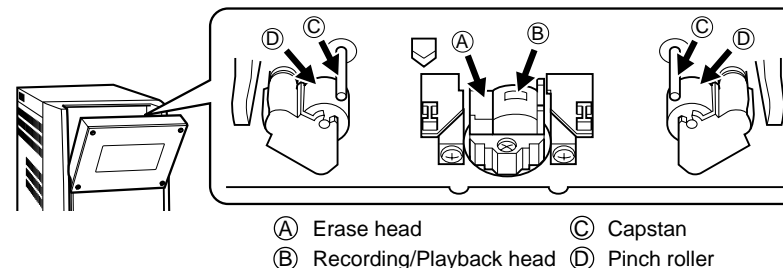

- After long use, the deck's heads and capstans may become magnetized, causing poor sound. Demagnetize these parts once every 30 hours of playing/recording time by using a commercial tape head demagnetizer. Read the demagnetizer's instructions carefully before use.

### ■ Cleaning the CD pickup lens

In order to ensure proper operation of the CD player, preventative maintenance (cleaning of the laser pickup lens) should be performed periodically. Lens cleaners are commercially available. Contact your local CD software dealer for options.

### ■ Cleaning the cabinet

Periodically wipe the cabinet with a soft cloth and a diluted soap solution, then with a dry cloth.

**Caution:**

- Do not use chemicals for cleaning (gasoline, paint thinner, etc.). It may damage the cabinet finish.
- Do not apply oil to the inside of the unit. It may cause malfunctions.

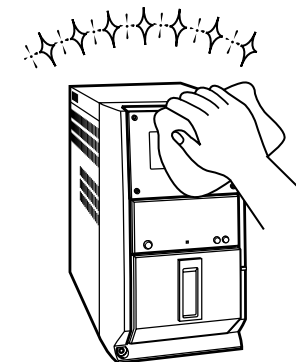



# Specifications

As part of our policy of continuous improvement, SHARP reserves the right to make design and specification changes for product improvement without prior notice. The performance specification figures indicated are nominal values of production units. There may be some deviations from these values in individual units.

## ■ General

<b>Power source</b>	AC 120 V, 60 Hz
<b>Power consumption</b>	175 W
<b>Dimensions</b>	Width: 7-7/8" (200 mm) Height: 13-7/8" (352 mm) Depth: 14-7/8" (377 mm)
<b>Weight</b>	21.4 lbs. (9.7 kg)

## ■ Amplifier

<b>Output power</b>	100 watts minimum RMS per channel into 6 ohms from 60 Hz to 20 kHz, 10 % total harmonic distortion Subwoofer: 60 W/ch (60 Hz - 200 Hz, 6 ohms, 10 % T.H.D.) Main: 40 W/ch (200 Hz - 20 kHz, 6 ohms, 10 % T.H.D.)
<b>Output terminals</b>	Speakers: 6 ohms Headphones: 16-50 ohms (recommended; 32 ohms)
<b>Input terminals</b>	Auxiliary: 500 mV/47 kohms

## ■ CD player

<b>Type</b>	6-disc multi-play compact disc player
<b>Signal readout</b>	Non-contact, 3-beam semiconductor laser pickup
<b>D/A converter</b>	1-bit D/A converter
<b>Frequency response</b>	20 - 20,000 Hz
<b>Dynamic range</b>	90 dB (1 kHz)

## ■ Cassette deck

<b>Frequency response</b>	50-14,000 Hz (Normal tape)
<b>Signal/noise ratio</b>	50 dB (recording/playback)
<b>Wow and flutter</b>	0.3 % (WRMS)

## ■ Tuner

<b>Frequency range</b>	FM: 87.5-108.0 MHz AM: 530-1,720 kHz
------------------------	---

## ■ Speaker

<b>Type</b>	3-way type speaker system 2" (5 cm) Tweeter 5-1/4" (13 cm) Woofer 5-1/4" (13 cm) Subwoofer
<b>Maximum input power (Total)</b>	200 W
<b>Rated input power (Total)</b>	100 W
<b>Impedance</b>	6 ohms
<b>Dimensions</b>	Width: 7-5/16" (185 mm) Height: 16-7/16" (417 mm) Depth: 12-1/4" (311 mm)
<b>Weight</b>	10.6 lbs. (4.8 kg)/each



## CONSUMER LIMITED WARRANTY

SHARP ELECTRONICS CORPORATION warrants to the first consumer purchaser that this Sharp brand product (the "Product"), when shipped in its original container, will be free from defective workmanship and materials, and agrees that it will, at its option, either repair the defect or replace the defective Product or part thereof with a new or remanufactured equivalent at no charge to the purchaser for parts or labor for the period(s) set forth below.

This warranty does not apply to any appearance items of the Product nor to the additional excluded item(s) set forth below nor to any Product the exterior of which has been damaged or defaced, which has been subjected to improper voltage or other misuse, abnormal service or handling, or which has been altered or modified in design or construction.

In order to enforce the rights under this limited warranty, the purchaser should follow the steps set forth below and provide proof of purchase to the servicer.

The limited warranty described herein is in addition to whatever implied warranties may be granted to purchasers by law. ALL IMPLIED WARRANTIES INCLUDING THE WARRANTIES OF MERCHANTABILITY AND FITNESS FOR USE ARE LIMITED TO THE PERIOD(S) FROM THE DATE OF PURCHASE SET FORTH BELOW. Some states do not allow limitations on how long an implied warranty lasts, so the above limitation may not apply to you.

Neither the sales personnel of the seller nor any other person is authorized to make any warranties other than those described herein, or to extend the duration of any warranties beyond the time period described herein on behalf of Sharp.

The warranties described herein shall be the sole and exclusive warranties granted by Sharp and shall be the sole and exclusive remedy available to the purchaser. Correction of defects, in the manner and for the period of time described herein, shall constitute complete fulfillment of all liabilities and responsibilities of Sharp to the purchaser with respect to the Product, and shall constitute full satisfaction of all claims, whether based on contract, negligence, strict liability or otherwise. In no event shall Sharp be liable, or in any way responsible, for any damages or defects in the Product which were caused by repairs or attempted repairs performed by anyone other than an authorized servicer. Nor shall Sharp be liable or in any way responsible for any incidental or consequential economic or property damage. Some states do not allow the exclusion of incidental or consequential damages, so the above exclusion may not apply to you.

THIS WARRANTY GIVES YOU SPECIFIC LEGAL RIGHTS. YOU MAY ALSO HAVE OTHER RIGHTS WHICH VARY FROM STATE TO STATE.

### Model Specific Section

**Your Product Model Number & Description:**

**CD-CH1500 Audio Tower System**

(Be sure to have this information available when you need service for your Product.)

**Warranty Period for this Product:**

One (1) year parts and labor from the date of purchase.

**Additional Item(s) Excluded from Warranty Coverage (if any):**

Non-functional accessories, supplies, and consumable items.

**Where to Obtain Service:**

At a Sharp Authorized Servicer located in the United States.  
To find a location of the nearest Sharp Authorized Servicer, call Sharp toll free at 1-800-BE-SHARP.

**What to do to Obtain Service:**

Ship prepaid or carry in your Product to a Sharp Authorized Servicer.  
Be sure to have **Proof of Purchase** available. If you ship the Product, be sure it is insured and packaged securely.

TO OBTAIN SUPPLY, ACCESSORY OR PRODUCT INFORMATION, CALL **1-800-BE-SHARP**.

**SHARP**  
**SHARP ELECTRONICS CORPORATION**  
Sharp Plaza, Mahwah, New Jersey 07430-2135  
**SHARP CORPORATION**

Printed in Malaysia  
TINSE0345AWZZ  
A0012.YT