

LC-42LB261U/LC-50LB261U

SHARP®

42"/50" LED TV

USER GUIDE



Before using your new product, please read these instructions to prevent any damage.

SHARP®

Contents

CHILD SAFETY	1
Important Safety Instructions	2
WARNING	2
CAUTION	3
Introduction	4
Roku Ready®	4
MHL™	4
CEC Control	4
Motion Enhancement	4
DTS Sound™	4
Game mode	4
Installing the stand or wall-mount bracket	5
Installing the stand	5
Installing a wall-mount bracket	7
TV components	10
Package contents	10
Front	10
Front buttons	10
Side	11
Back	12
Remote control	13
What connection should I use?	14
Connecting a cable or satellite box	15
HDMI (best)	15
DVI (same as HDMI but requires an audio connection)	16
Component video (better)	17
AV (composite video) (good).....	18
Coaxial (good).....	19
Connecting an antenna or cable TV (no box)	20
Connecting a DVD or Blu-ray player	21
HDMI (best)	21
Component video (better)	22
AV (composite video) (good).....	23

- Connecting a Roku Streaming Stick24
- Connecting an MHL-enabled device25
- Connecting a game console26
 - HDMI (best) 26
 - Component video (better) 27
 - AV (composite video) (good)..... 28
- Connecting a computer29
 - HDMI (best) 29
 - DVI (same as HDMI but requires an audio connection) 30
 - VGA (most common) 31
- Connecting a USB flash drive32
- Connecting headphones33
- Connecting external speakers or a sound bar34
 - Digital audio 34
 - Analog audio 35
- Connecting a home theater system with multiple devices36
- Connecting power37
- Using the remote control38
 - Installing remote control batteries 38
 - Aiming the remote control 38
 - Programming universal remote controls 39
 - Viewing universal remote control codes 39
- Turning on your TV for the first time40
- Understanding the basics42
 - Turning your TV on or off 42
 - Selecting the video input source 42
 - On-screen menu overview 42
 - Navigating the menus 43
 - Selecting a channel 44
 - Adjusting the volume 44
 - Viewing channel information 44
- Using a Roku Streaming Stick44
 - Connecting and using 44
 - Switching back to the Roku Streaming Stick 45
- Using an MHL-enabled device45
 - Connecting and using 45
 - Switching back to the connected device 46
- Using CEC Control46
 - Turning CEC Control on or off 46
 - Turning Device Auto Power Off on or off 47

Turning TV Auto Power On on or off	47
Turning Audio Return Channel on or off	48
Displaying a list of CEC-compatible devices	48
Selecting a CEC-compatible device	49
Opening a CEC-compatible device's root menu	49
Using a USB flash drive	50
Switching to USB mode	50
Browsing photos	50
Viewing favorite photos	51
Viewing photos in a slideshow	51
Adjusting the picture	52
Adjusting the TV picture	52
Automatically adjusting the aspect ratio	53
Setting the power on picture mode	54
Adjusting the computer image	54
Adjusting the sound	55
Adjusting sound settings	55
Selecting the audio out mode	56
Playing TV audio only	57
Changing channel settings	57
Automatically scanning for channels	57
Hiding channels	58
Setting up a favorite channel list	59
Viewing a favorite channel	59
Adding or changing a channel label	60
Checking the digital signal strength	61
Setting parental controls	61
Setting or changing the password	61
Blocking unrated TV	62
Setting parental control levels	63
Downloading rating information	64
Locking control buttons	65
Using closed captioning	66
Turning closed captioning on or off	66
Selecting the analog closed captioning mode	66
Selecting the digital closed captioning mode	67
Customizing digital closed captioning settings	67
Adjusting time settings	68
Setting the clock	68
Setting the sleep timer	69
Adjusting menu settings	70
Selecting the menu language	70
Turning Input Sensor on or off	70
Labeling an input source	71

- Maintenance71
 - Cleaning the TV cabinet 71
 - Cleaning the TV screen 71
- Troubleshooting71
 - Viewing system information 71
 - Learning more 72
 - Updating the TV firmware 72
 - Restoring settings to the defaults 73
 - Video and audio 73
 - Remote control 76
 - General 76
 - Roku Streaming Stick 77
 - MHL-enabled device 78
 - CEC-compatible device 78
- Specifications81
- Legal notices82
- One-year limited warranty - Sharp Televisions83

CHILD SAFETY

PROPER TELEVISION PLACEMENT MATTERS



THE CONSUMER ELECTRONICS INDUSTRY CARES

- Manufacturers, retailers and the rest of the consumer electronics industry are committed to making home entertainment safe and enjoyable.
- As you enjoy your television, please note that all televisions - new and old- must be supported on proper stands or installed according to the manufacturer's recommendations. Televisions that are inappropriately situated on dressers, bookcases, shelves, desks, speakers, chests, carts, etc., may fall over, resulting in injury.



TUNE IN TO SAFETY

- **ALWAYS** follow the manufacturer's recommendations for the safe installation of your television.
- **ALWAYS** read and follow all instructions for proper use of your television.
- **NEVER** allow children to climb on or play on the television or the furniture on which the television is placed.
- **NEVER** place the television on furniture that can easily be used as steps, such as a chest of drawers.
- **ALWAYS** install the television where it cannot be pushed, pulled over or knocked down.
- **ALWAYS** route cords and cables connected to the television so that they cannot be tripped over, pulled or grabbed.



WALL OR CEILING MOUNT YOUR TELEVISION

- **ALWAYS** contact your retailer about professional installation if you have any doubts about your ability to safely mount your television.
- **ALWAYS** use a mount that has been recommended by the television manufacturer and has a safety certification by an independent laboratory (such as UL, CSA, ETL).
- **ALWAYS** follow all instructions supplied by the television and mount manufacturers.
- **ALWAYS** make sure that the wall or ceiling where you are mounting the television is appropriate. Some mounts are not designed to be mounted to walls and ceilings with steel studs or cinder block construction. If you are unsure, contact a professional installer.
- Televisions can be heavy. A minimum of two people is required for a wall or ceiling mount installation.



MOVING AN OLDER TELEVISION TO A NEW PLACE IN YOUR HOME

- Many new television buyers move their older CRT televisions into a secondary room after the purchase of a flat-panel television. Special care should be made in the placement of older CRT televisions.
- **ALWAYS** place your older CRT television on furniture that is sturdy and appropriate for its size and weight.
- **NEVER** place your older CRT television on a dresser where children may be tempted to use the drawers to climb.
- **ALWAYS** make sure your older CRT television does not hang over the edge of your furniture.



Important Safety Instructions



This symbol indicates that dangerous voltage constituting a risk of electric shock is present within your TV. This label is located on the back of your TV.



This symbol indicates that there are important operating and maintenance instructions in the literature accompanying your TV.

- 1 Read these instructions.
- 2 Keep these instructions.
- 3 Heed all warnings.
- 4 Follow all instructions.
- 5 Do not use this apparatus near water.
- 6 Clean only with dry cloth.
- 7 Do not block any ventilation openings. Install in accordance with the manufacturer's instructions.
- 8 Do not install near any heat sources such as radiators, heat registers, stoves, or other apparatus (including amplifiers) that produce heat.
- 9 Do not defeat the safety purpose of the polarized or grounding-type plug. A polarized plug has two blades with one wider than the other. A grounding type plug has two blades and a third grounding prong. The wide blade or the third prong are provided for your safety. If the provided plug does not fit into your outlet, consult an electrician for replacement of the obsolete outlet.
- 10 Protect the power cord from being walked on or pinched particularly at plugs, convenience receptacles, and the point where they exit from the apparatus.
- 11 Only use attachments/accessories specified by the manufacturer.
- 12 Use only with the cart, stand, tripod, bracket, or table specified by the manufacturer, or sold with the apparatus. When a cart is used, use caution when moving the cart/apparatus combination to avoid injury from tip-over.
- 13 Unplug this apparatus during lightning storms or when unused for long periods of time.
- 14 Refer all servicing to qualified service personnel. Servicing is required when the apparatus has been damaged in any way, such as power-supply cord or plug is damaged, liquid has been spilled or objects have fallen into the apparatus, the apparatus has been exposed to rain or moisture, does not operate normally, or has been dropped.



S3125A

- 15 The wall plug is the disconnecting device. The plug must remain readily operable.
- 16 Remote control batteries should not be exposed to excessive heat such as sunshine, fire, or the like.
- 17 The apparatus should not be exposed to dripping or splashing, and no objects filled with liquids, such as vases, should be placed on the apparatus.
- 18 Your TV has four VESA mounting holes on the back. If you attach a wall-mount bracket or TV stand to the back of your TV, **the bracket or stand must be securely attached using to all four holes.** If you do not use all four mounting holes, your TV may fall and cause property damage or personal injury. See the documentation that came with your wall mount or TV stand for complete mounting instructions.

WARNING

Electric shock hazard

To reduce the risk of fire or electric shock, do not remove any cover or expose the device to rain or moisture. No user-serviceable parts are inside. Refer servicing to qualified service technicians.

Lightning

For added protection for your device receiver during a lightning storm, or when it is left unattended and unused for long periods of time, unplug it from the power outlet and disconnect any antenna or cable system. This helps prevent property damage and personal injury from lightning and power line surges.

Power lines

An outside antenna system should not be located in the vicinity of overhead power lines or other electric light or power circuits, or where it can fall into such power lines or circuits. When installing an outside antenna system, take extreme care to keep from touching such power lines or circuits as contact with them might be fatal.

Handling the LCD panel

- Your TV's screen is made of glass. Do not drop your TV or hit, jolt, or press hard against the LCD panel. If the screen breaks, be careful of broken glass.
- If the LCD panel is broken, make absolutely sure that you do not touch the liquid in the panel. This may cause skin inflammation.
- If the liquid gets in your mouth, immediately gargle, rinse, and consult with your doctor. Also, if the liquid gets in your eyes or touches your skin, consult with your doctor after rinsing for at least 15 minutes or longer in clean water.

Replacement parts

When replacement parts are required, make sure that the service technician uses replacement parts specified by the manufacturer that have the same characteristics as the original part. Unauthorized substitutions may result in fire, electric shock, personal injury, or other hazards.

Safety check

After completing any service or repair to this device, ask the service technician to perform routine safety checks to determine that your TV is in correct operating condition.

Power source

Operate your TV only from the type of power source indicated on the marking label. If you are not sure of the type of power supplied to your home, consult an electrician or your local power company.

Servicing

These servicing instructions are for use by qualified service personnel only. To reduce the risk of electric shock, do not perform any servicing other than that contained in the operating instructions unless you are qualified to do so.

CAUTION

Damage requiring service

Unplug this TV from the power outlet and refer servicing to qualified service personnel under the following conditions:

- When the power supply cord or plug is damaged or frayed.
- If liquid has been spilled or objects have fallen into your TV.
- If your TV has been exposed to rain or water.
- If your TV does not operate normally by following the operating instructions. Adjust only those controls covered by the operating instructions because incorrect adjustment of other controls may result in damage and will often require extensive work by a qualified technician to restore your TV to its normal operation.
- If your TV has been dropped or damaged in any way.
- When your TV exhibits a distinct change in performance.

Outdoor antenna grounding

If an outside antenna or cable system is connected to your TV, make sure that the antenna or cable system is grounded to provide some protection against voltage surges and built-up static charges. Article 810 of the National Electrical Code, ANSI/NFPA No. 70, provides information with respect to correct grounding of the mast and supporting structure, grounding of the lead-in wire to an antenna discharge unit, size of grounding conductors, location of the antenna-discharge unit, connection to grounding electrodes, and requirements for the grounding electrode.

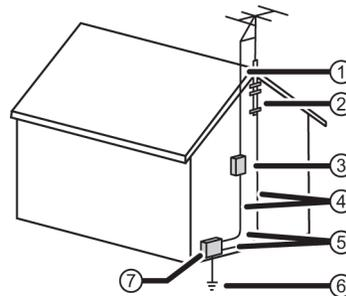

- ① Antenna lead-in wire
- ② Grounding clamp
- ③ Antenna discharge unit
- ④ Grounding conductors
- ⑤ Ground clamps
- ⑥ Power service grounding electrode system
- ⑦ Electric service equipment

Note to CATV system installer

Article 820 of the National Electrical Code, ANSI/NFPA No. 40 provides guidance for correct grounding. Specifically, it states that the cable ground must be connected to the grounding system of the building as close to the point of cable entry as practical.

Condensation

Moisture will form on the TV if the TV is brought from cool surroundings into a warm room or if the temperature of the room rises suddenly. When this happens, the TV's performance may be impaired. To prevent this, let the TV stand in its new surroundings for about an hour before switching it on, or make sure that the room temperature rises gradually.

Condensation may also form during the summer if the TV is exposed to the breeze from an air conditioner. In such cases, change the location of the TV.

Mobile telephone warning

To avoid interference with your TV picture and sound, operating problems, or even damage, keep your cordless and cellular telephones away from the TV.

End of life directives

Your TV may contain materials that are regulated for environmental reasons. Your TV also contains materials that can be recycled and reused. To help protect the environment, contact your local authorities for information about disposal or recycling and about finding a recycler in your area before you dispose of your TV.

Non-active pixels

The LCD panel contains almost 3 million thin film transistors, which provide exceptionally sharp video quality. Occasionally, a few non-active pixels may appear on the screen as a fixed blue, green, or red point. These non-active pixels do not adversely affect the performance of your TV, and are not considered defects.

Sharp 42"/50" LED TV

Introduction

Congratulations on your purchase of a high-quality Sharp product. Your LC-42LB261U or LC-50LB261U represents the state of the art in LED TV design and is designed for reliable and trouble-free performance.

Roku Ready®

Your Sharp TV is certified to work with the Roku Streaming Stick® (sold separately) to instantly stream 1000+ entertainment channels, including Netflix, M-GO, HBO GO, Hulu Plus, WatchESPN, Vudu, Amazon Instant Video, Pandora, PBS, and many more. Operate the Streaming Stick with your TV remote or a mobile device —it's that simple! Just plug the Streaming Stick into the purple MHL port on your TV and enjoy. Roku requires high-speed Internet and WiFi. (See page 24 for connection instructions.)

MHL™

Connect your MHL-enabled device, such as a cell phone, and view your device's screen on your TV. Supports 1080p HD video and 5.1 digital surround sound playback from your mobile device. (Requires an MHL-enabled phone or tablet and an MHL cable.) (See page 25 for connection instructions.)

CEC Control

Enjoy the benefit of having HDMI CEC compatible products plug and play! No setup is needed! CEC technology lets different components discover and communicate with each other. (See page 46 for instructions on how to use CEC Control.)

Motion Enhancement

With a 120Hz screen refresh rate twice the rate of a 60Hz screen, a screen with 1,080 lines of resolution (up from 720 lines in the last generation of HDTVs), and special motion-detection technology, you will experience a picture with clearer detail and brightness, smoother transitions, and reduced motion blurring, particularly when watching fast-motion sports and action scenes. (See the Motion Enhancement option in "[Adjusting the TV picture](#)" on page 52 for information.)

DTS Sound™

DTS Sound delivers clear, crisp, and natural sound while providing deep enveloping bass.

Game mode

Video games generally require adjustments to the television picture settings to get the maximum experience. By simply pressing a button on your remote control, your television settings will automatically adjust for video games. It couldn't be easier. (See the **Game** option in "[Adjusting the TV picture](#)" on page 52 for instruction on how to select Game mode.)

Note

The backs of the 42-inch and 50-inch models look slightly different. The jack locations and names are the same for both models.

The graphics in this *User Guide* show the 42-inch model unless otherwise noted.

Installing the stand or wall-mount bracket

Notes

- If you plan to wall-mount your TV, do not install the stand.
- Store the stand and stand screws in case you decide to use the stand in the future.

Installing the stand

- 1 Carefully place your TV face-down on a cushioned, clean surface to protect the screen from damages and scratches.

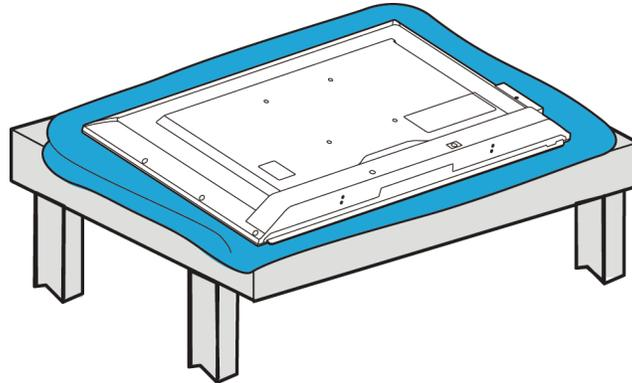

- 2 Insert the stand column into the TV.

42-inch model

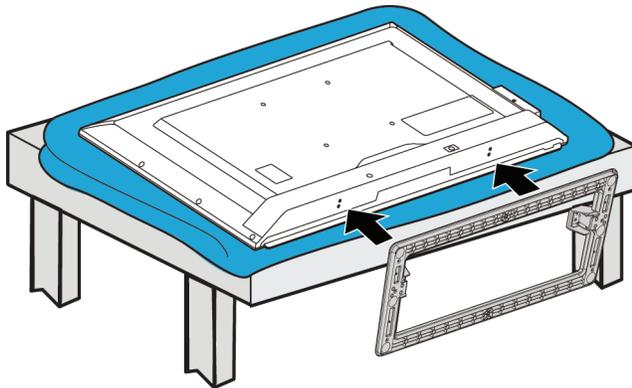

50-inch model

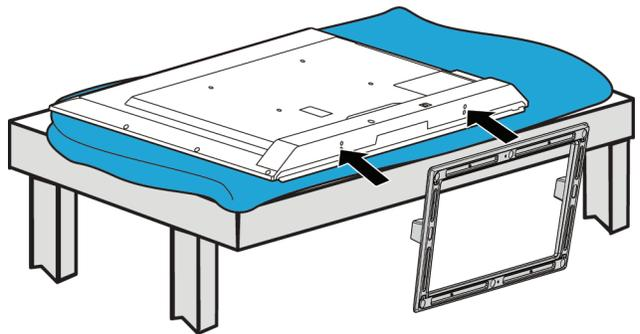

3 Secure the TV stand to your TV with the four provided screws.

42-inch model

Screw type	Screw length	# of screws
M4	18 mm	4

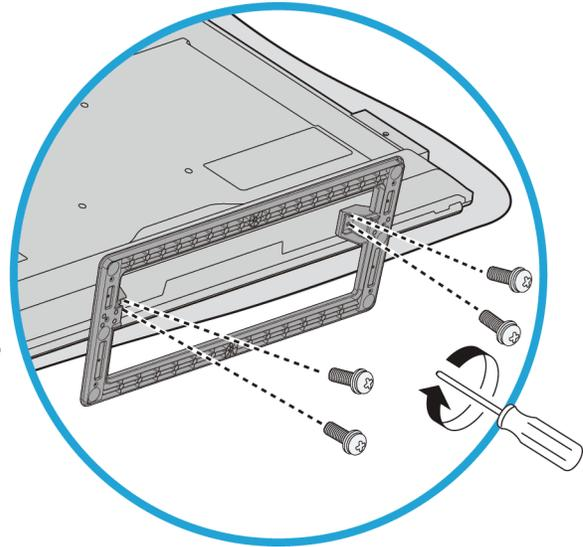
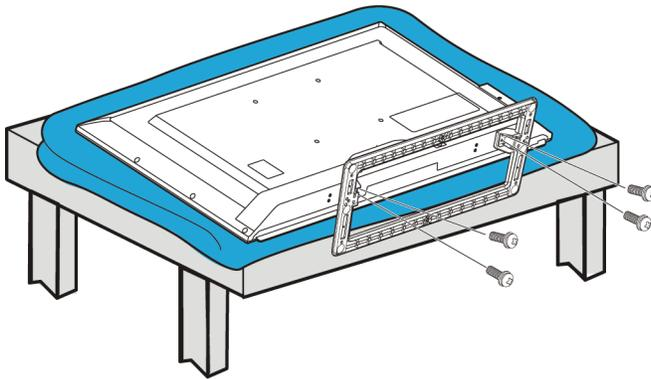

50-inch model

Screw type	Screw length	# of screws
M6	20 mm	4

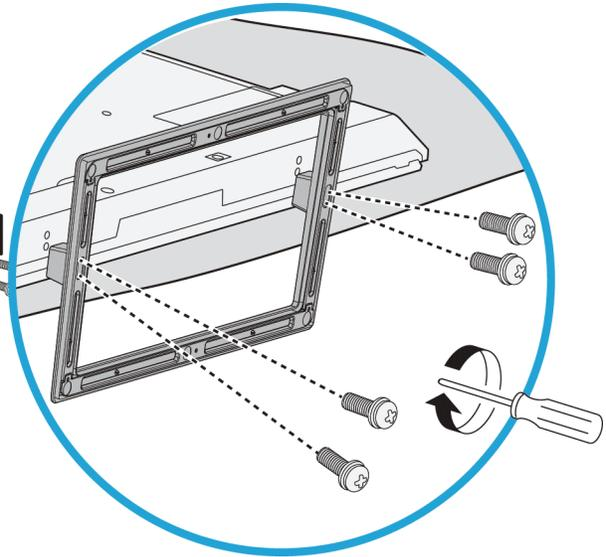
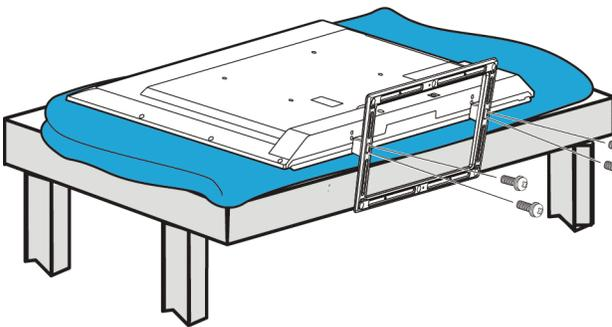

Installing a wall-mount bracket

Warning

- Your TV has four VESA mounting holes on the back. If you attach a wall-mount bracket to the back of your TV, **the bracket must be securely attached, using all four holes.** If you do not use all four mounting holes, your TV may fall and cause property damage or personal injury. See the documentation that came with your wall mount for complete mounting instructions.
- This TV is intended to be supported by a UL Listed wall mount bracket with suitable weight/load. (See "[Miscellaneous](#)" on page 81.)
- To prevent injury, this apparatus must be securely attached to the floor/wall in accordance with the installation instructions.

- 1 Carefully place your TV face-down on a cushioned, clean surface to protect the screen from damages and scratches.

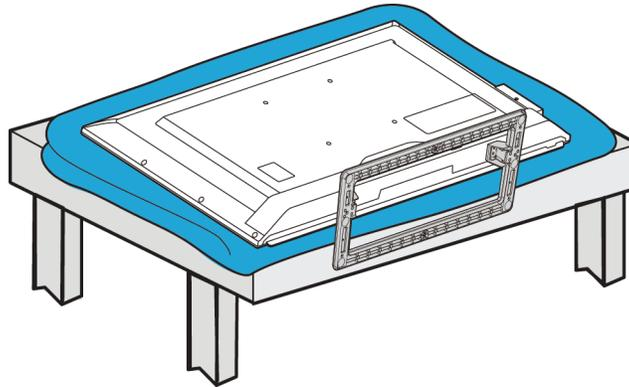

2 If the TV stand is attached, remove the four screws that secure the stand to your TV.

42-inch model

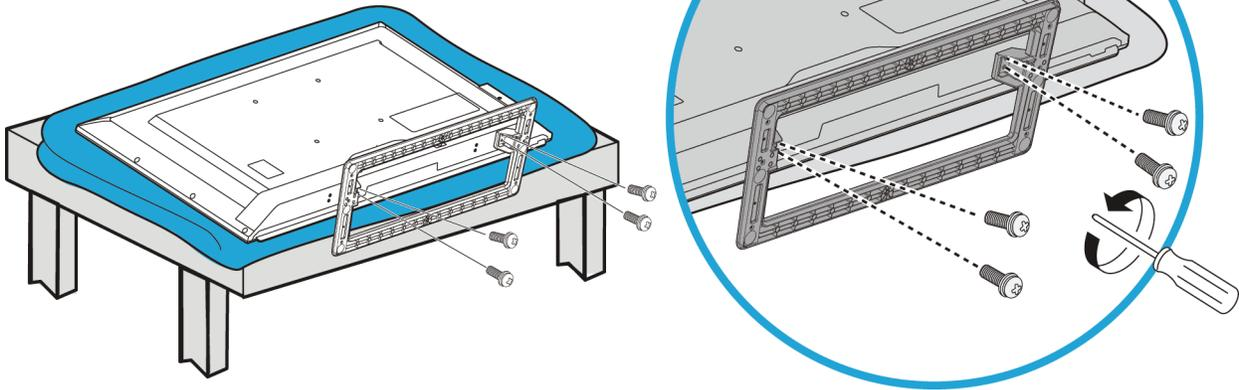

50-inch model

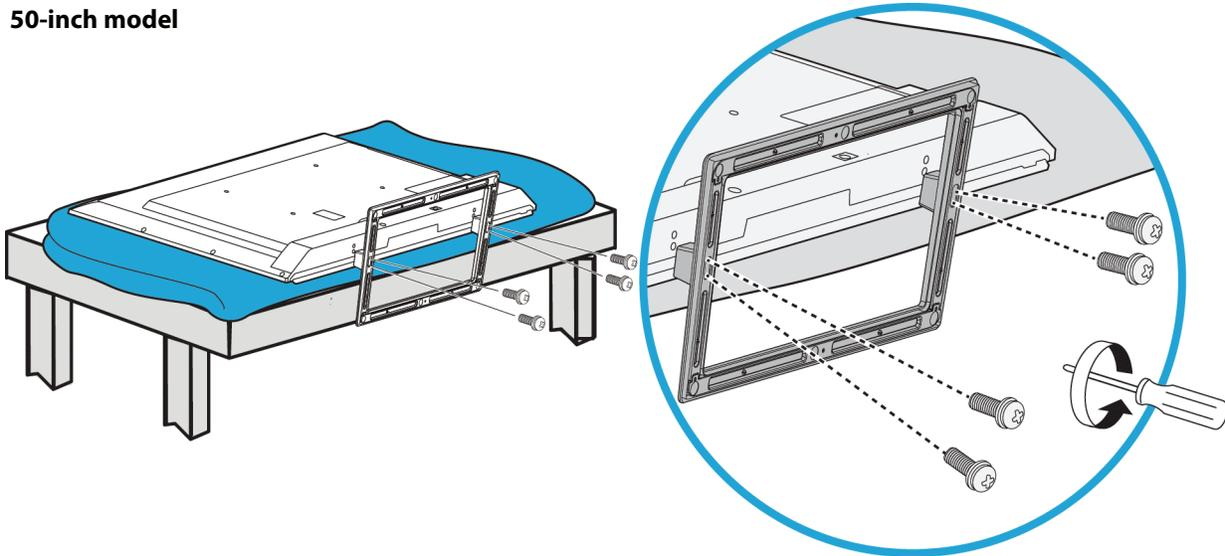

Notes

- The length of the wall-mount screws vary depending on the wall-mount bracket you purchased. See the instructions that came with the wall-mount bracket for screw lengths.
- The mounting holes on the back of your TV take type M6 screws.

42-inch model 7.87 in. (200 mm)

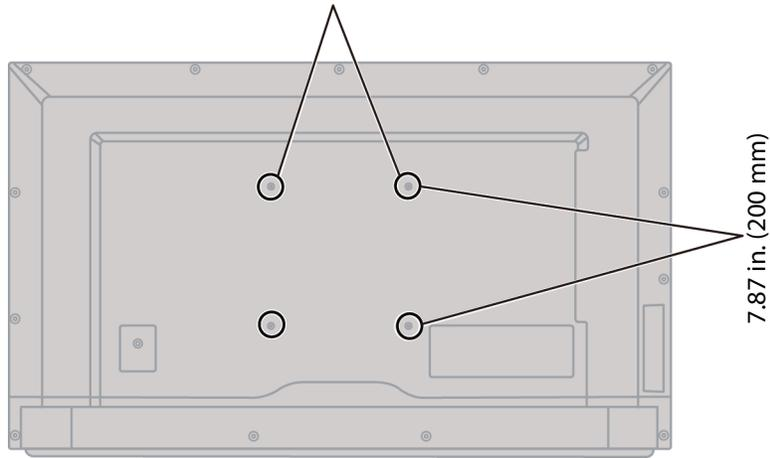

50-inch model 15.74 in. (400 mm)

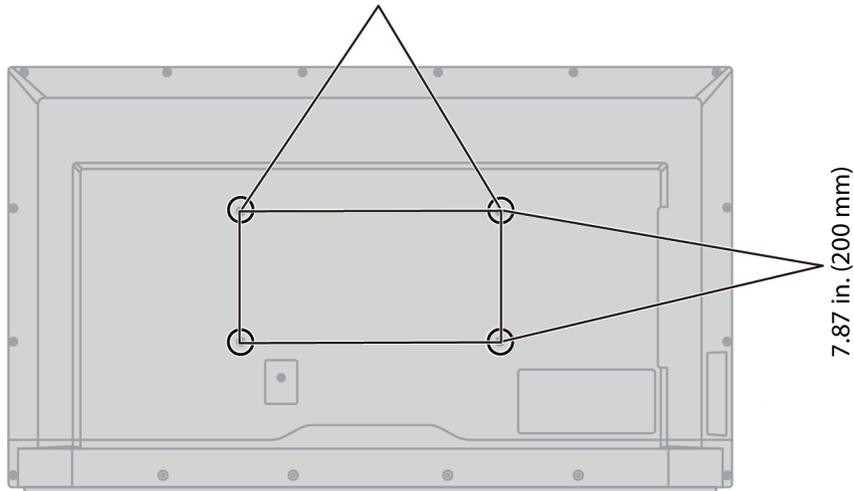

TV components

Package contents

- 42" LED TV or 50" LED TV
- Remote control and batteries (2 AAA)
- TV stand and screws (4)
- Power cord
- *Quick Setup Guide*
- *Important Information*

Front

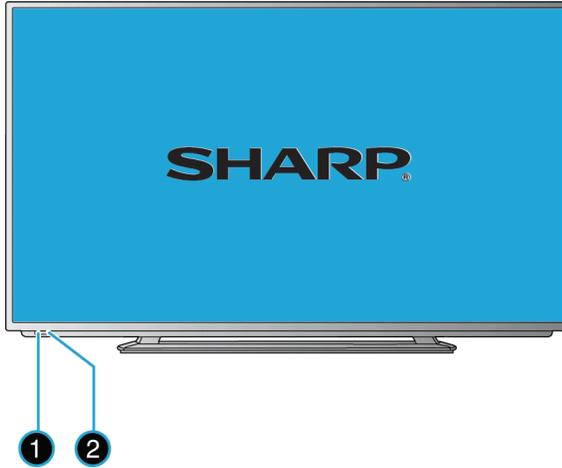

#	Item	Description
1	Remote control sensor	Receives signals from the remote control. Do not block.
2	Power indicator	Lights blue when your TV is on. Lights red when your TV is off (standby mode).

Front buttons

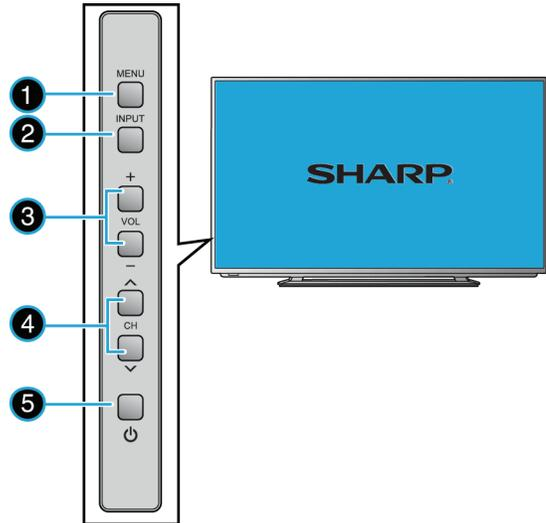

#	Item	Description
1	MENU	Press to open the on-screen menu. For more information, see “Navigating the menus” on page 43.
2	INPUT	Press one or more times to select the video input source you want, then wait a few seconds. Your TV switches to the source you selected. For more information, see “Selecting the video input source” on page 42. In menu mode, press to confirm selections.
3	VOL+/VOL-	Press to increase or decrease the volume.
4	CH ^/CH v	Press to go to the next or previous channel in the channel list. For more information, see “Selecting a channel” on page 44.
5	⏻ (power)	Press to turn your TV on or off (standby mode). Warning: When your TV is off, power still flows through it. To completely disconnect power, unplug the power cord.

Side

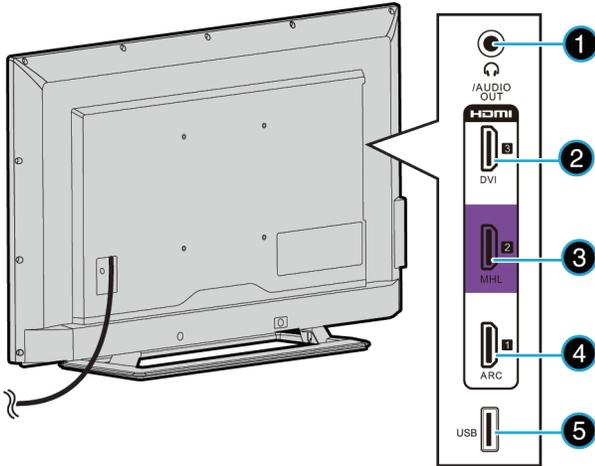

#	Item	Description
1	🎧/AUDIO OUT	Connect headphones, an analog audio amplifier, a home theater system, or a sound bar to this jack. For more information, see "Connecting headphones" on page 33 or "Analog audio" on page 35.
2	HDMI 3/DVI	<p>Connect an HDMI device to this jack. For more information, see "HDMI (best)" on pages 15, 21, 26, or 29.</p> <p>OR</p> <p>Connect the video for a DVI device to this jack. For more information, see "DVI (same as HDMI but requires an audio connection)" on pages 16, or 30.</p>
3	HDMI 2/MHL	<p>Connect an HDMI device to this jack. For more information, see "HDMI (best)" on pages 15, 21, 26, or 29.</p> <p>OR</p> <p>Connect an MHL-enabled device, such as a cell phone or Roku Streaming Stick™, to this jack to view your device's screen on your TV.</p> <p>For more information about MHL, see "Connecting an MHL-enabled device" on page 25 and "Using an MHL-enabled device" on page 45.</p> <p>For more information about Roku, see "Connecting a Roku Streaming Stick" on page 24 and "Using a Roku Streaming Stick" on page 44.</p>
4	HDMI 1/ARC	<p>Connect an HDMI device to this jack. For more information, see "HDMI (best)" on pages 15, 21, 26, or 29.</p> <p>OR</p> <p>Connect a home theater that supports ARC to this jack.</p>
5	USB	Connect a USB flash drive to this jack to view compatible JPEG picture files. For more information, see "Connecting a USB flash drive" on page 32 and "Using a USB flash drive" on page 50.

Back

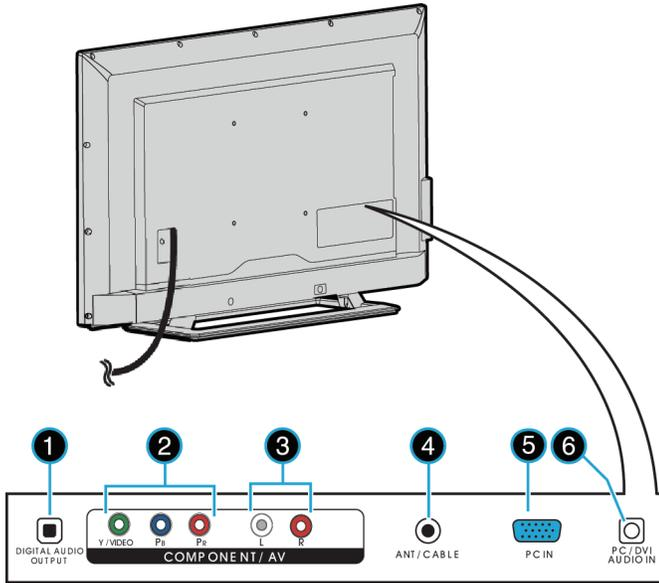

#	Item	Description
4	ANT/CABLE	Connect an antenna or cable TV to this jack. For more information, see “Coaxial (good)” on page 19 or “Connecting an antenna or cable TV (no box)” on page 20.
5	PC IN	Connect the video (VGA) for a computer to this jack. For more information, see “VGA (most common)” on page 31.
6	PC/DVI AUDIO IN	Connect the audio for a computer to this jack. For more information see “VGA (most common)” on page 31. OR Connect the audio for a DVI device to this jack. For more information see, “DVI (same as HDMI but requires an audio connection)” on pages 16 or 30.

#	Item	Description
1	DIGITAL AUDIO OUTPUT (optical)	Connect a digital audio amplifier, home theater system, or sound bar to this jack to listen to TV audio through the external speakers. For more information, see “Digital audio” on page 34.
2	Y/VIDEO, Pb, Pr OR Y/VIDEO	The Y/VIDEO jack works as one of the three component video jacks or as an AV jack. Connect the video for a component video device to these jacks. For more information, see “Component video (better)” on page 17, 22, or 27. OR Connect the video for an AV device to the Y/VIDEO jack. For more information, see “AV (composite video) (good)” on page 18, 23, or 28.
3	L and R (audio)	Connect the audio for a component video device to these jacks. For more information, see “Component video (better)” on page 17, 22, or 27. OR Connect the audio for an AV device to these jacks. For more information, see “AV (composite video) (good)” on page 18, 23, or 28.

Remote control

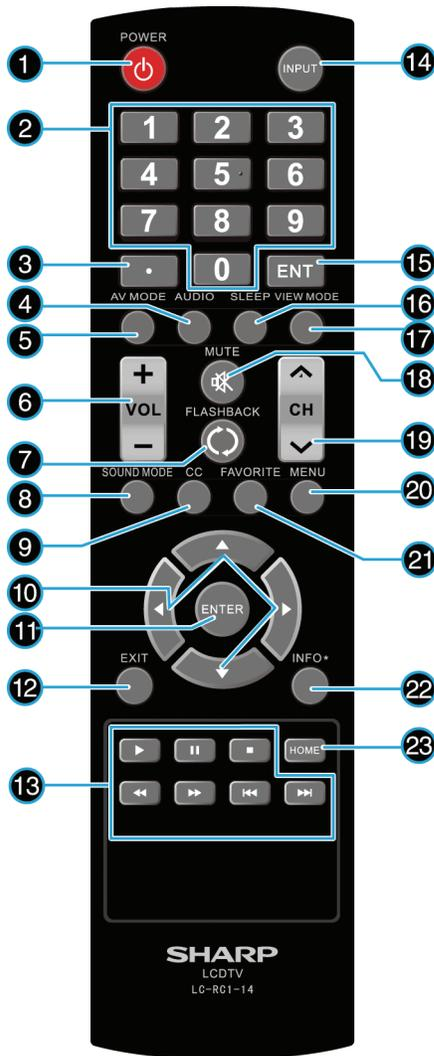

#	Button	Press to...
1	POWER	Turn your TV on or off (standby mode). Warning: When your TV is off, power still flows through it. To disconnect power, unplug the power cord.
2	Numbers	Enter channel numbers and the parental control password.
3	●	Enter a digital sub-channel number. See “Selecting a channel” on page 44.
4	AUDIO	Select the audio mode for an analog program. You can select: <ul style="list-style-type: none"> • Mono—Select this option if there is noise or static on weak stereo broadcasts. • Stereo—Select this option for programs broadcast in stereo. • SAP—Select this option to listen to a secondary audio program, if available. OR Select the audio language for a digital program, if alternate languages are available.
5	AV MODE	Select the AV (picture) mode. You can select Dynamic, Natural, Standard, Movie, Game, or User . See the AV Mode option in “Adjusting the TV picture” on page 52.

#	Button	Press to...
6	VOL+/-	Increase or decrease the volume.
7	↺ FLASHBACK	Return to the previous channel.
8	SOUND MODE	Select the sound mode. You can select Standard, Movie, Music, Voice, Game, or User . See the Sound Mode option in “Adjusting sound settings” on page 55.
9	CC	Turn closed captioning on or off. You can select Off, On Always, or On When Mute . See “Turning closed captioning on or off” on page 66.
10	▲ ▼ ◀ ▶	TV —Navigate in on-screen menus and to adjust settings. Roku —Navigate in Roku screens.
11	ENTER	Confirm selections or changes or to open sub-menus.
12	EXIT	TV —Close the on-screen menu. Roku —Close menus or videos.
13	Media controls	CEC —Control CEC devices connected to your TV. See “Using CEC Control” on page 46. Roku —Control a movie or show that is playing. USB —Control a photo slideshow.
14	INPUT	Open the INPUT SOURCE list, press ▲ or ▼ on the remote control to select the video input source, then press ENTER . See “Selecting the video input source” on page 42.
15	ENT	Go to the channel you selected using the number buttons.
16	SLEEP	Set the sleep timer. You can select Off, 5, 10, 15, 30, 60, 90, 120, 180, or 240 minutes. See “Setting the sleep timer” on page 69.
17	VIEW MODE	Change how the picture looks on the screen (aspect ratio). See the Aspect ratio option in “Adjusting the TV picture” on page 52.
18	🔇 MUTE	Mute on-unmute the sound.
19	CH ▲/CH ▼	Change TV channels. For more information, see “Selecting a channel” on page 44.
20	MENU	Open the on-screen menu.
21	FAVORITE	Open the FAVORITES LIST . See “Setting up a favorite channel list” on page 59 and “Viewing a favorite channel” on page 59.
22	INFO*	TV —Display TV status information, such as the channel number, channel name (if available), or signal source. See “Viewing channel information” on page 44. Roku —Access special Roku options when a Roku Streaming Stick is plugged in.
23	HOME	TV —Open the on-screen menu if your TV does not have an MHL jack. MHL —Open the MHL device’s home menu when an MHL device is plugged in. See “Using an MHL-enabled device” on page 45. Roku —Switch to a connected Roku Streaming Stick when a Roku Streaming Stick is plugged in. See “Using a Roku Streaming Stick” on page 44.

What connection should I use?

Your TV has several connection types for connecting devices to your TV.

For the best video quality, you should connect a device to the best available connection.

Use the following tables to identify cables:

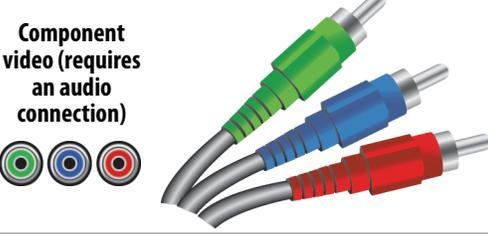
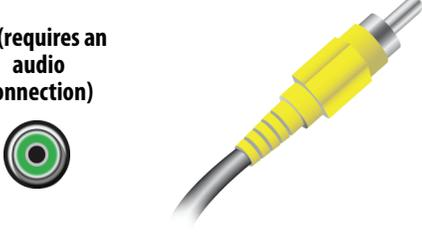
Video quality	Connection type and jack	Cable connector
Best (use this if your devices have HDMI)	HDMI video/audio	
Better than composite or coaxial	Component video (requires an audio connection)	
Better than coaxial	AV (requires an audio connection)	
Good	Coaxial video/audio	

Connection type and jack

Optical digital audio



Analog audio input

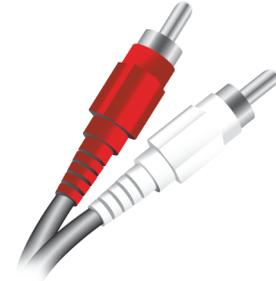

Analog audio output



VGA (computer) video and audio

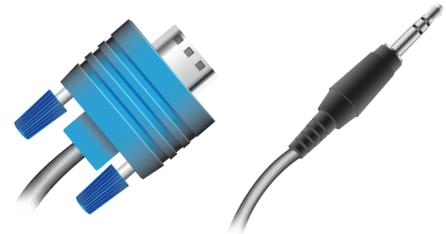

You can use the **HDMI 3/DVI** jack on your TV to connect a DVI device to your TV. For more information, see "[DVI \(same as HDMI but requires an audio connection\)](#)" on page 16 or 30.

Cautions

- Check the jacks for position and type before making any connections.
- Loose connections can result in image or color problems. Make sure that all connections are tight and secure.
- The external audio/video equipment shown may be different from your equipment. If you have questions, refer to the documentation that came with your equipment.
- Always unplug the power cord when connecting external equipment.

Connecting a cable or satellite box

Many cable or satellite TV boxes have more than one connection type. To get the best video, you should use the best connection type available. For more information, see [“What connection should I use?”](#) on page 14.

HDMI (best)

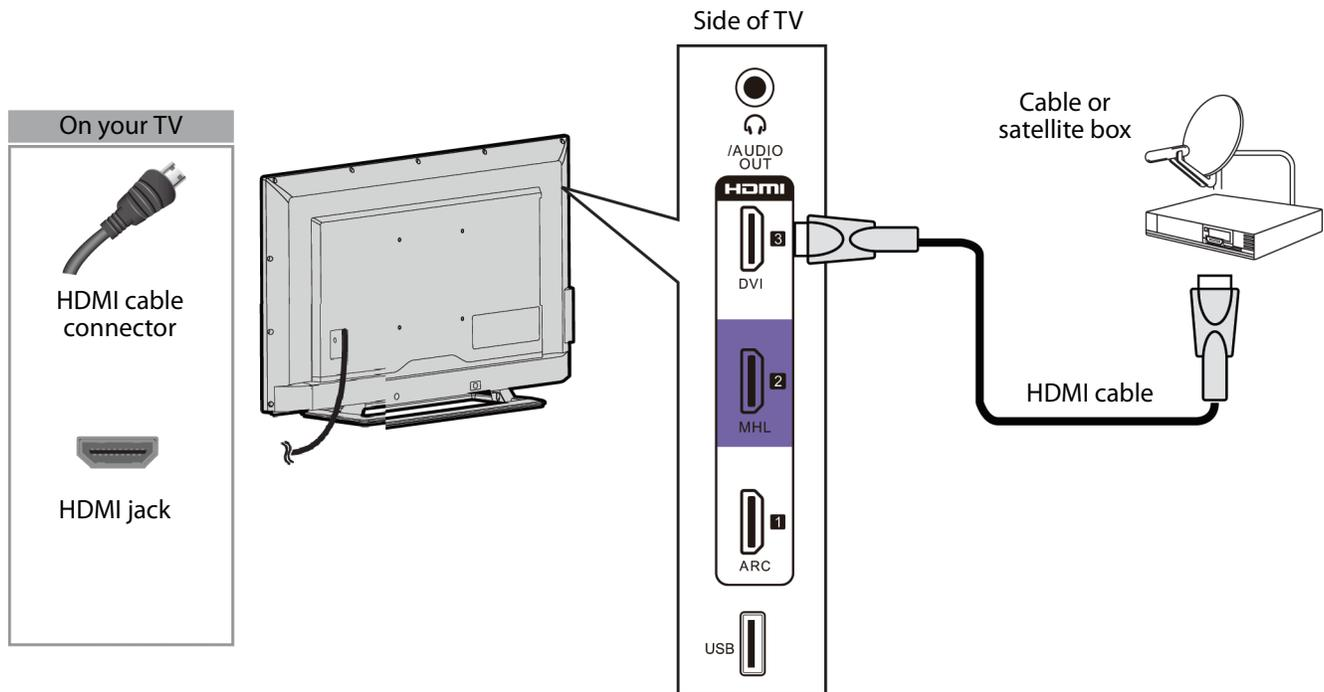

- 1 Make sure that your TV's power cord is unplugged and all connected equipment is turned off.
- 2 Connect the incoming cable from the cable wall jack to the cable-in jack on the cable or satellite box.
- 3 Connect an HDMI cable (not provided) to one of the **HDMI** jacks on the side of your TV and to the **HDMI OUT** jack on the cable or satellite box.
- 4 Plug your TV's power cord into a power outlet, turn on your TV, then turn on the cable or satellite box.
- 5 Press **INPUT** to open the *INPUT SOURCE* list.
- 6 Press **▲** or **▼** to highlight **HDMI 1**, **HDMI 2**, or **HDMI 3**, then press **ENTER**.

Note

An HDMI cable carries both audio and video. You do not need to use any audio cables.

DVI (same as HDMI but requires an audio connection)

Note
You must use the **HDMI 3/DVI** jack to connect a cable or satellite box using DVI. If you use another HDMI jack, you will not hear sound from the TV speakers.

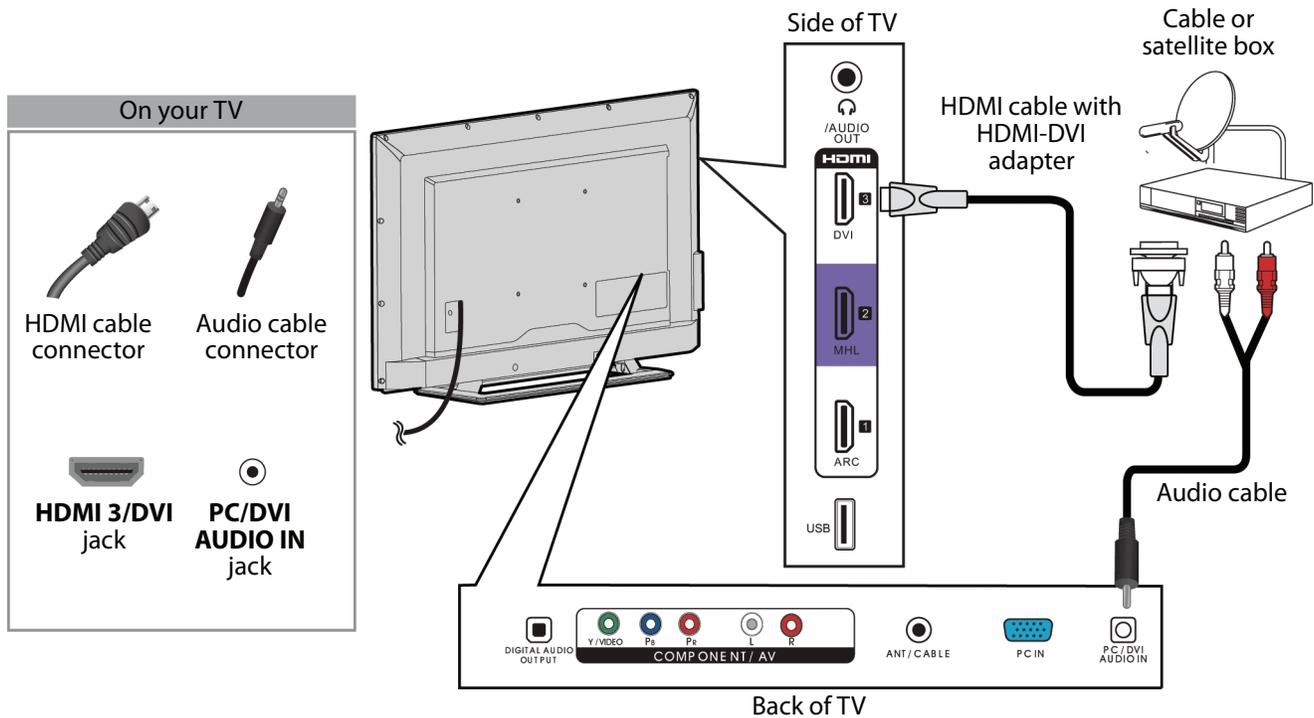

- 1 Make sure that your TV's power cord is unplugged and all connected equipment is turned off.
- 2 Connect the incoming cable from the cable wall jack to the cable-in jack on the cable or satellite box.
- 3 Connect an HDMI-DVI adapter (not provided) to one end of an HDMI cable (not provided), then connect the adapter to the **DVI OUT** jack on the cable or satellite box.
- 4 Connect the other end of the cable to the **HDMI 3/DVI** jack on the side of your TV.
- 5 Connect an audio cable (not provided) to the **PC/DVI AUDIO IN** jack on the back of your TV and to the **AUDIO OUT** jacks on the cable or satellite box.

Note
When you connect the audio using the **PC/DVI AUDIO IN** jack, the audio output is analog.

- 6 Plug your TV's power cord into a power outlet, turn on your TV, then turn on the cable or satellite box.
- 7 Press **INPUT** to open the *INPUT SOURCE* list.
- 8 Press **▲** or **▼** to select **HDMI 3**, then press **ENTER**.

Component video (better)

Note
Cables are often color-coded to match color-coded jacks.

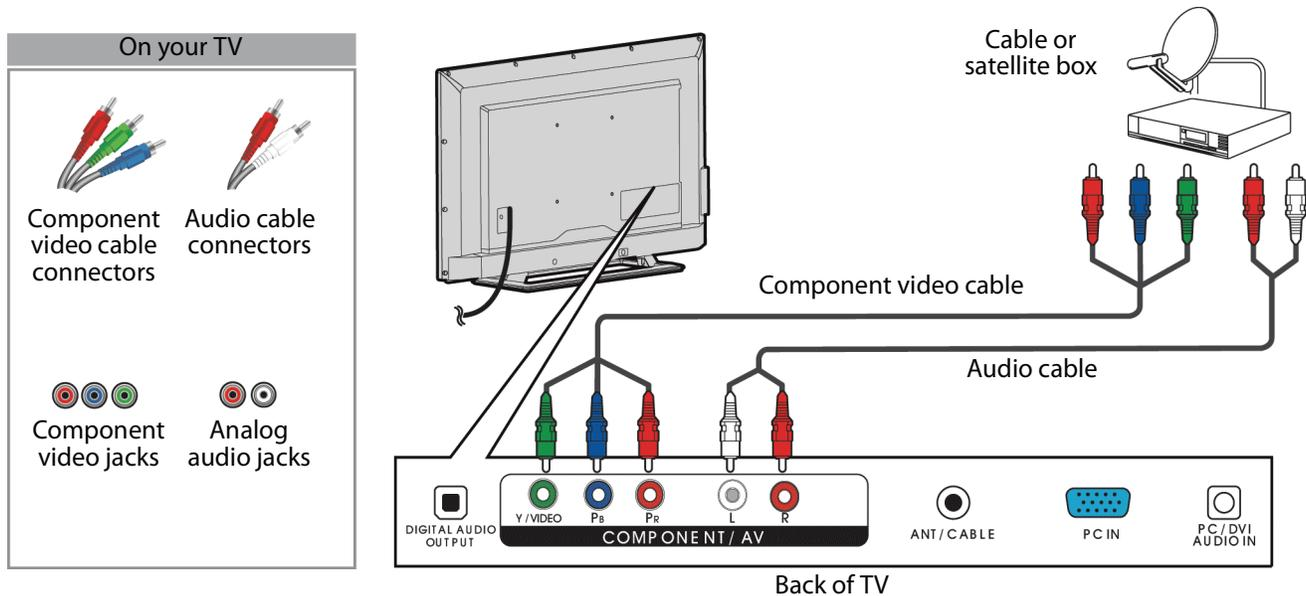

- 1 Make sure that your TV's power cord is unplugged and all connected equipment is turned off.
- 2 Connect the incoming cable from the cable wall jack to the cable-in jack on the cable or satellite box.
- 3 Connect a component video cable (not provided) to the **Y/VIDEO**, **Pb**, and **Pr** video jacks on the back of your TV and the component video out jacks on the cable or satellite box.
- 4 Connect an audio cable (not provided) to the **L** and **R** audio jacks on the back of your TV and to the audio out jacks on the cable or satellite TV box.

Important

- The **Y/VIDEO**, **Pb**, and **Pr** video jacks (used to connect a component video device) share the **L** and **R** audio jacks with the **Y/VIDEO** jack (used to connect an AV device). You can only connect one component video or AV device at a time. We suggest upgrading to HDMI if your DVD or Blu-ray player supports it.
- When you connect the audio using the **L** and **R** audio jacks, the audio output is analog.

- 5 Plug your TV's power cord into a power outlet, turn on your TV, then turn on the cable or satellite box.
- 6 Press **INPUT** to open the *INPUT SOURCE* list.
- 7 Press **▲** or **▼** to select **Component**, then press **ENTER**.

AV (composite video) (good)

Notes

- Cables are often color-coded to match color-coded jacks.
- The yellow video connector on the AV cable connects to the green **Y/VIDEO** jack.

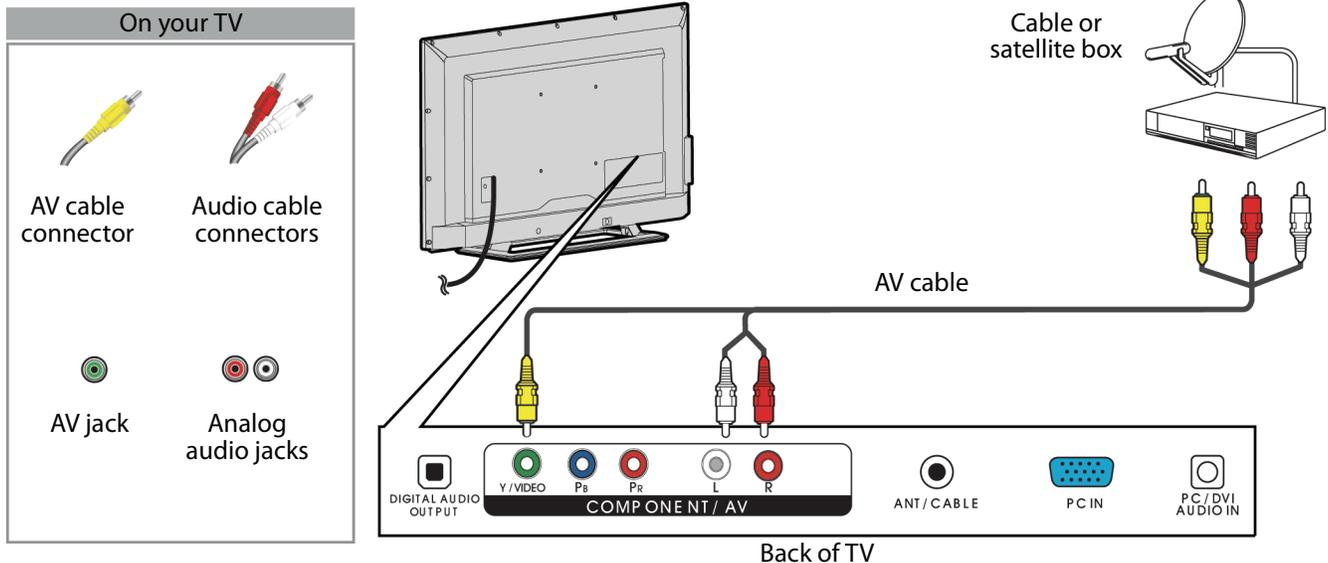

- 1 Make sure that your TV's power cord is unplugged and all connected equipment is turned off.
- 2 Connect the incoming cable from the cable wall jack to the cable-in jack on the cable or satellite box.
- 3 Connect an AV cable (not provided) to the **Y/VIDEO** jack and **L** and **R** audio jacks on the back of your TV and to the AV and audio out jacks on the cable or satellite box.

Important

- The **Y/VIDEO**, **Pb**, and **Pr** video jacks (used to connect a component video device) share the **L** and **R** audio jacks with the **Y/VIDEO** jack (used to connect an AV device). You can only connect one component video or AV device at a time. We suggest upgrading to HDMI if your DVD or Blu-ray player supports it.
- When you connect the audio using the **L** and **R** audio jacks, the audio output is analog.

- 4 Plug your TV's power cord into a power outlet, turn on your TV, then turn on the cable or satellite box.
- 5 Press **INPUT** to open the *INPUT SOURCE* list.
- 6 Press **▲** or **▼** to select **AV**, then press **ENTER**.

Coaxial (good)

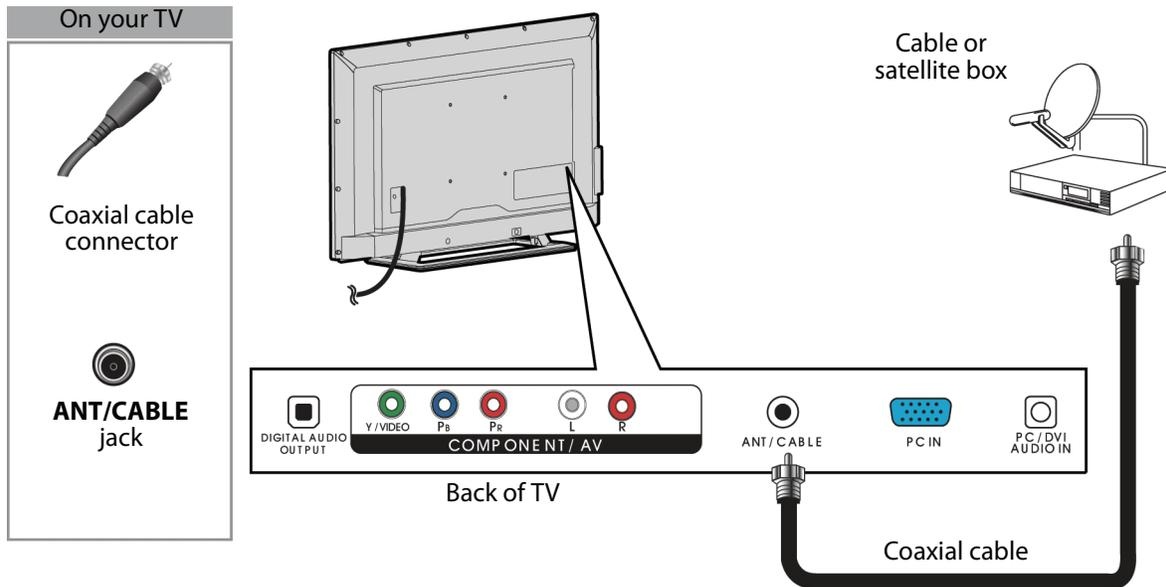

- 1 Make sure that your TV's power cord is unplugged and all connected equipment is turned off.
- 2 Connect the incoming cable from the cable wall jack to the cable-in jack on the cable or satellite box.
- 3 Connect a coaxial cable (not provided) to the **ANT/CABLE** jack on the back of your TV and to the coaxial out jack on the cable or satellite box.
- 4 Plug your TV's power cord into a power outlet, turn on your TV, then turn on the cable or satellite box.
- 5 Press **INPUT** to open the *INPUT SOURCE* list.
- 6 Press **▲** or **▼** to highlight **TV**, then press **ENTER**.
- 7 If you cannot tune to channels you know exist, scan for channels. See "[Automatically scanning for channels](#)" on page 57.

Notes

- Use a coaxial cable to eliminate interference and noise from radio waves.
- Do not bundle the coaxial cable with the power cord or other cables.

Connecting an antenna or cable TV (no box)

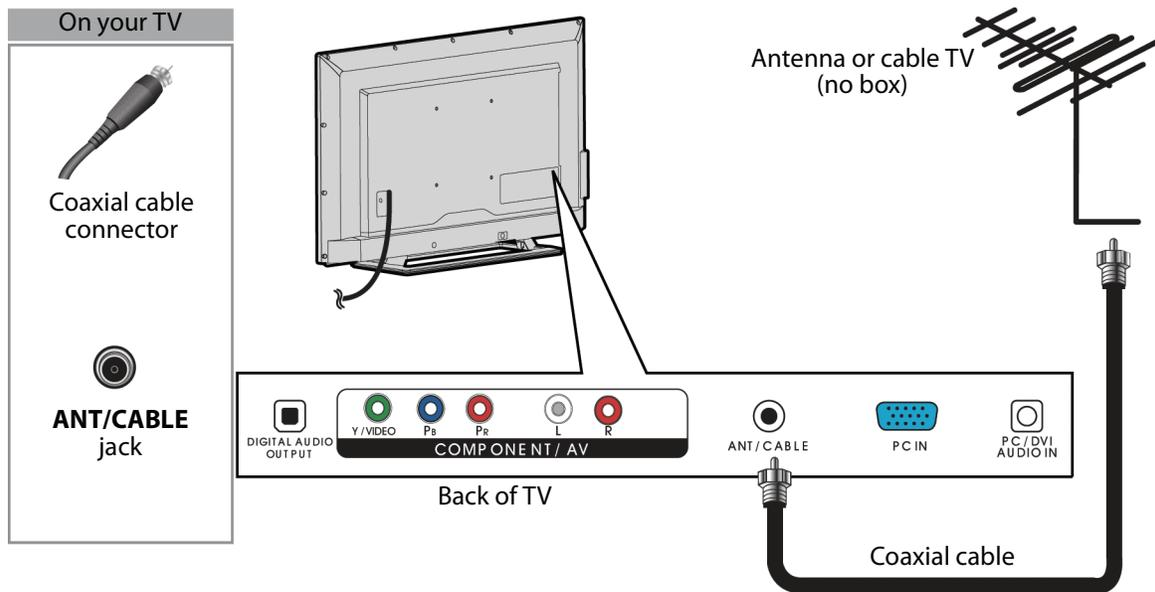

- 1 Make sure that your TV's power cord is unplugged and all connected equipment is turned off.
- 2 Connect a coaxial cable (not provided) to the **ANT/CABLE** jack on the back of your TV and to the antenna or cable TV wall jack.
- 3 Plug your TV's power cord into a power outlet, then turn on your TV.
- 4 Press **INPUT** to open the *INPUT SOURCE* list.
- 5 Press **▲** or **▼** to highlight **TV**, then press **ENTER**.
- 6 If you cannot tune to channels you know exist, scan for channels. See "[Automatically scanning for channels](#)" on page 57.

Notes

- Use a coaxial cable to eliminate interference and noise from radio waves.
- Do not bundle the coaxial cable with the power cord or other cables.
- If the antenna is not installed correctly, contact qualified service personnel to correct the problem.
- If the signal level for a channel is weak, the picture may be distorted. Adjust the antenna or use a highly directional outdoor or set-top antenna with a built-in amplifier.
- If the picture quality is good on some channels and poor on others, the problem may be caused by a poor or weak signal from the broadcaster or cable TV provider.
- If you connect to cable or satellite TV without a set-top box and experience poor picture quality, you may need to install a set-top box to improve signal reception and picture quality. Contact your cable or satellite TV provider about upgrading to a set-top box.
- Many high-definition (HD) channels upscale standard-definition (SD) content. The picture displayed on your TV is still displayed as SD, thus the picture quality will not be as clear or crisp as it would be if the content was originally recorded in HD.

Connecting a DVD or Blu-ray player

Many DVD or Blu-ray players have more than one connection type. To get the best video, you should use the best connection type available. For more information, see [“What connection should I use?”](#) on page 14.

HDMI (best)

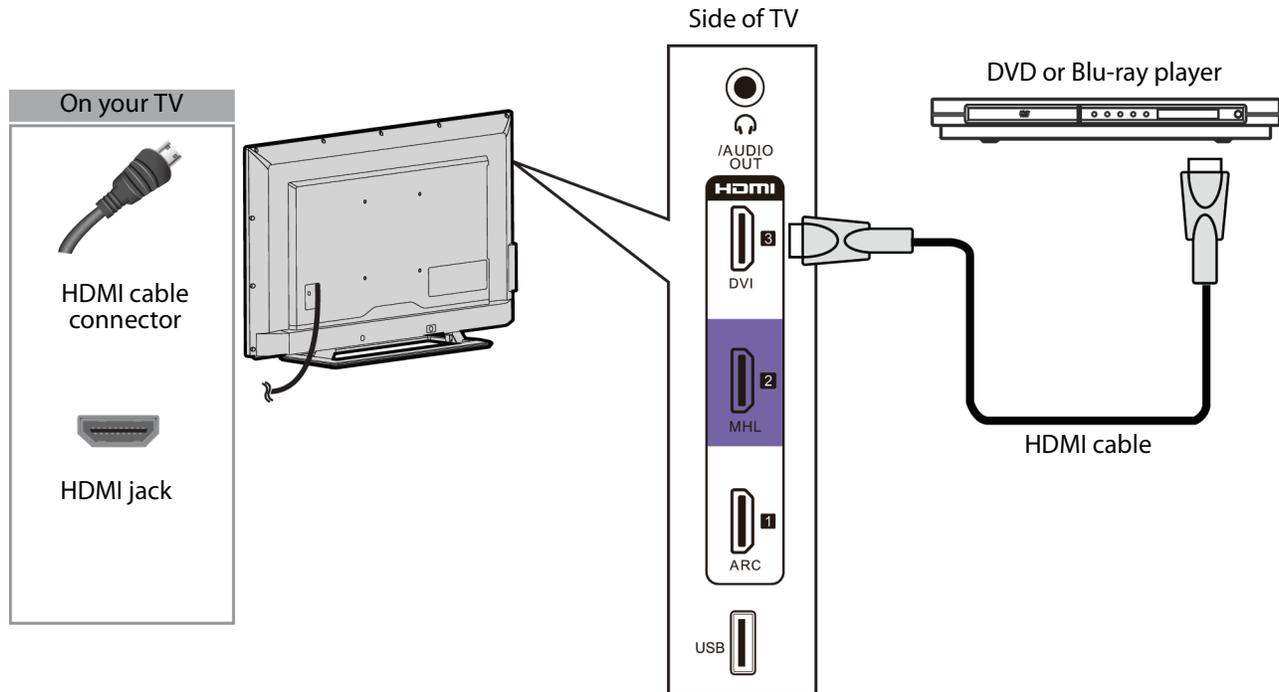

- 1 Make sure that your TV's power cord is unplugged and the DVD or Blu-ray player is turned off.
- 2 Connect an HDMI cable (not provided) to one of the **HDMI** jacks on the side of your TV and to the **HDMI OUT** jack on the DVD or Blu-ray player.
- 3 Plug your TV's power cord into a power outlet, then turn on your TV and the DVD or Blu-ray player.
- 4 Press **INPUT** to open the *INPUT SOURCE* list.
- 5 Press **▲** or **▼** to highlight **HDMI 1**, **HDMI 2**, or **HDMI 3**, then press **ENTER**.

Note

An HDMI cable carries both audio and video. You do not need to use any audio cables.

Component video (better)

Note
Cables are often color-coded to match color-coded jacks.

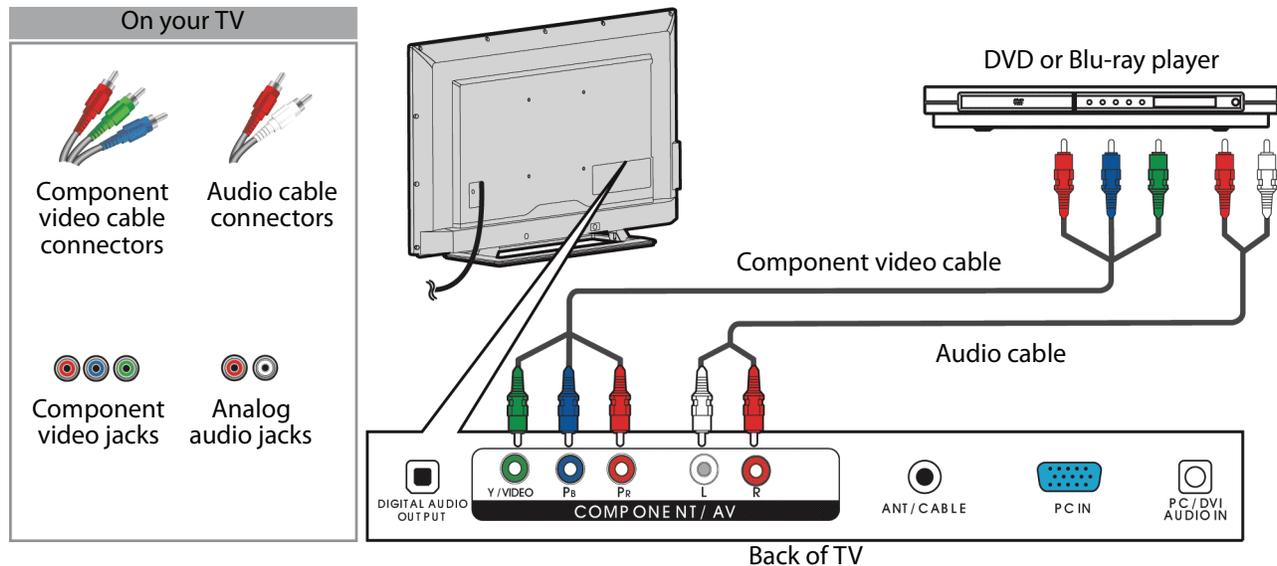

- 1 Make sure that your TV's power cord is unplugged and the DVD or Blu-ray player is turned off.
- 2 Connect a component video cable (not provided) to the **Y/VIDEO**, **Pb**, and **Pr** jacks on the back of your TV and to the **COMPONENT OUT** jacks on the DVD or Blu-ray player.
- 3 Connect an audio cable (not provided) to the **L** and **R** audio jacks on the back of your TV and to the **L** and **R AUDIO OUT** jacks on the DVD or Blu-ray player.

Important

- The **Y/VIDEO**, **Pb**, and **Pr** video jacks (used to connect a component video device) share the **L** and **R** audio jacks with the **Y/VIDEO** jack (used to connect an AV device). You can only connect one component video or AV device at a time. We suggest upgrading to HDMI if your cable or satellite box supports it.
- When you connect the audio using the **L** and **R** audio jacks, the audio output is analog.

- 4 Plug your TV's power cord into a power outlet, then turn on your TV and the DVD or Blu-ray player.
- 5 Press **INPUT** to open the **INPUT SOURCE** list.
- 6 Press **▲** or **▼** to select **Component**, then press **ENTER**.

AV (composite video) (good)

Notes

- Cables are often color-coded to match color-coded jacks.
- The yellow video connector on the AV cable connects to the green **Y/VIDEO** jack.

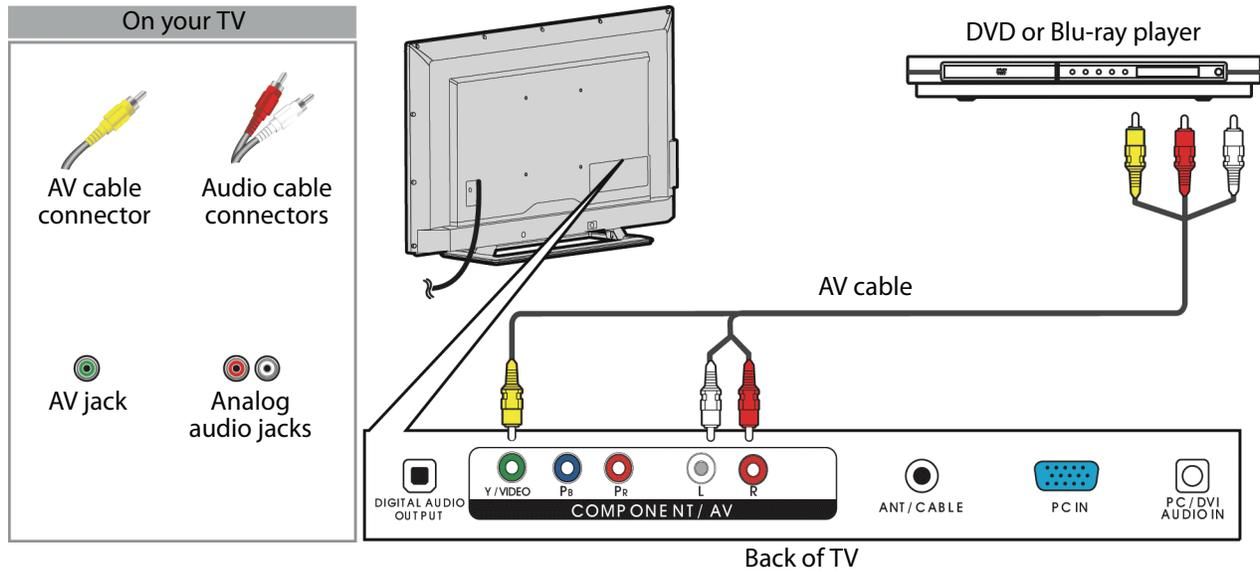

- 1 Make sure that your TV's power cord is unplugged and the DVD or Blu-ray player is turned off.
- 2 Connect an AV cable (not provided) to the **Y/VIDEO** jack and **L** and **R** audio jacks on the back of your TV and to the **AV OUT** jacks on the DVD or Blu-ray player.

Important

- The **Y/VIDEO**, **Pb**, and **Pr** video jacks (used to connect a component video device) share the **L** and **R** audio jacks with the **Y/VIDEO** jack (used to connect an AV device). You can only connect one component video or AV device at a time. We suggest upgrading to HDMI if your cable or satellite box supports it.
- When you connect the audio using the **L** and **R** audio jacks, the audio output is analog.

- 3 Plug your TV's power cord into a power outlet, then turn on your TV and the DVD or Blu-ray player.
- 4 Press **INPUT** to open the *INPUT SOURCE* list.
- 5 Press **▲** or **▼** to select **AV**, then press **ENTER**.

Connecting a Roku Streaming Stick

You can connect a Roku Streaming Stick® to your TV to enjoy streaming video and audio.

Note

You must use the purple **HDMI 2/MHL** jack to connect a Roku Streaming Stick.

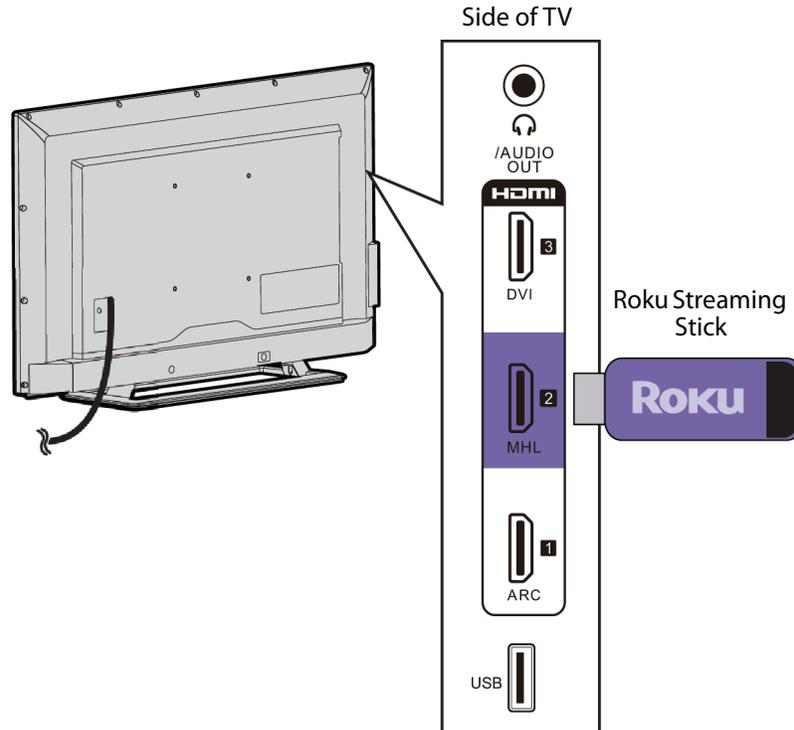

- 1 Plug the Roku Streaming Stick (not provided) into the purple **HDMI 2/MHL** jack on the side of your TV.
 - 2 If your TV is turned on, press **ENTER** when a message appears. Your Roku Streaming Stick's menu opens. (The message may take about 20 seconds to appear.)
- OR
- If your TV is turned off, turn on your TV. Press **HOME**. Your Roku Streaming Stick's menu opens.

Notes

You can also switch to Roku mode by:

- Pressing **INPUT** and selecting **HDMI 2 (Roku)**
- Pressing **MENU** and selecting **Roku**

For instructions on using your Roku Streaming Stick, see "[Using a Roku Streaming Stick](#)" on page 44.

Connecting an MHL-enabled device

You can connect an MHL-enabled device, such as a cell phone, and view your device's screen on your TV.

Note

You must use the purple **HDMI 2/MHL** jack to connect an MHL-enabled device.

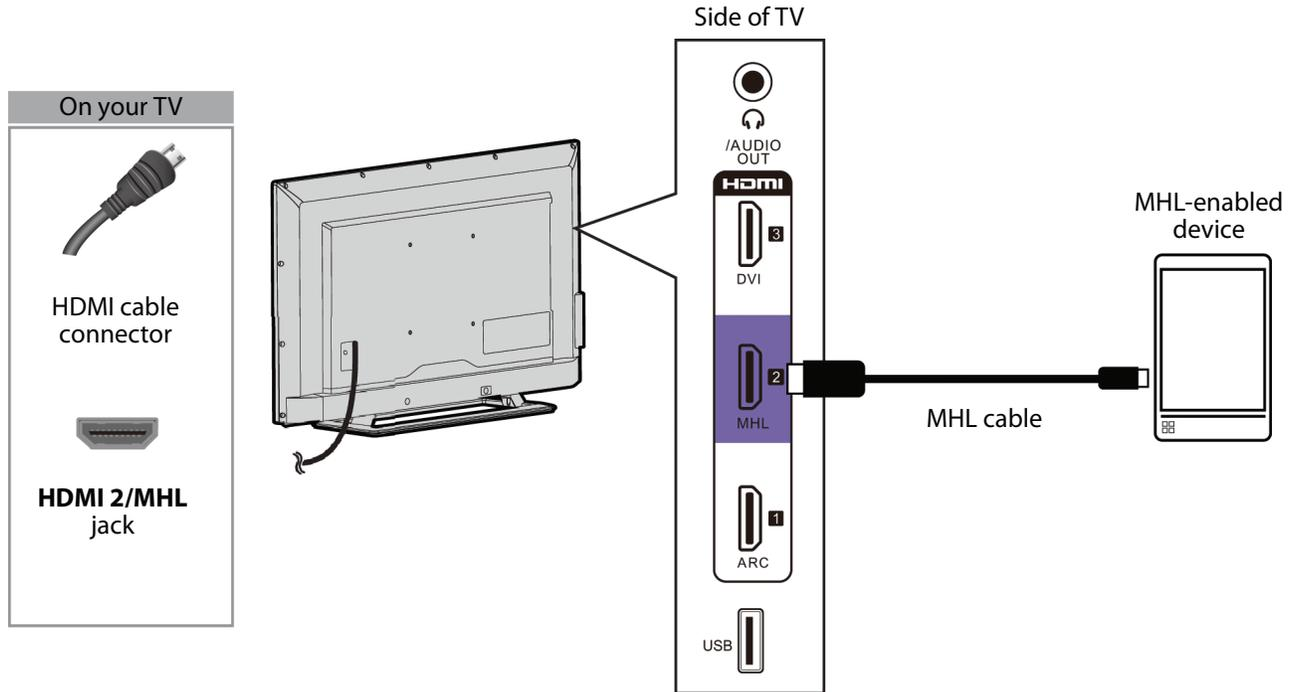

- 1 Connect the small connector on an MHL cable (not provided) to the micro USB port on the MHL-enabled device.
- 2 Connect the other end of the cable to the **HDMI 2/MHL** jack on the side of your TV.
- 3 Turn on the MHL-enabled device.
- 4 If your TV is turned on, press **ENTER** when a message appears. Your MHL-enabled device's menu opens.
OR
If your TV is turned off, turn on your TV. Press **HOME**. Your MHL-enabled device's menu opens.

Notes

You can also switch to MHL mode by:

- Pressing **INPUT** and selecting **HDMI 2 (MHL)**
- Pressing **MENU** and selecting **MHL**

For instructions on using your MHL-enabled device, see ["Using an MHL-enabled device"](#) on page 45.

Connecting a game console

HDMI (best)

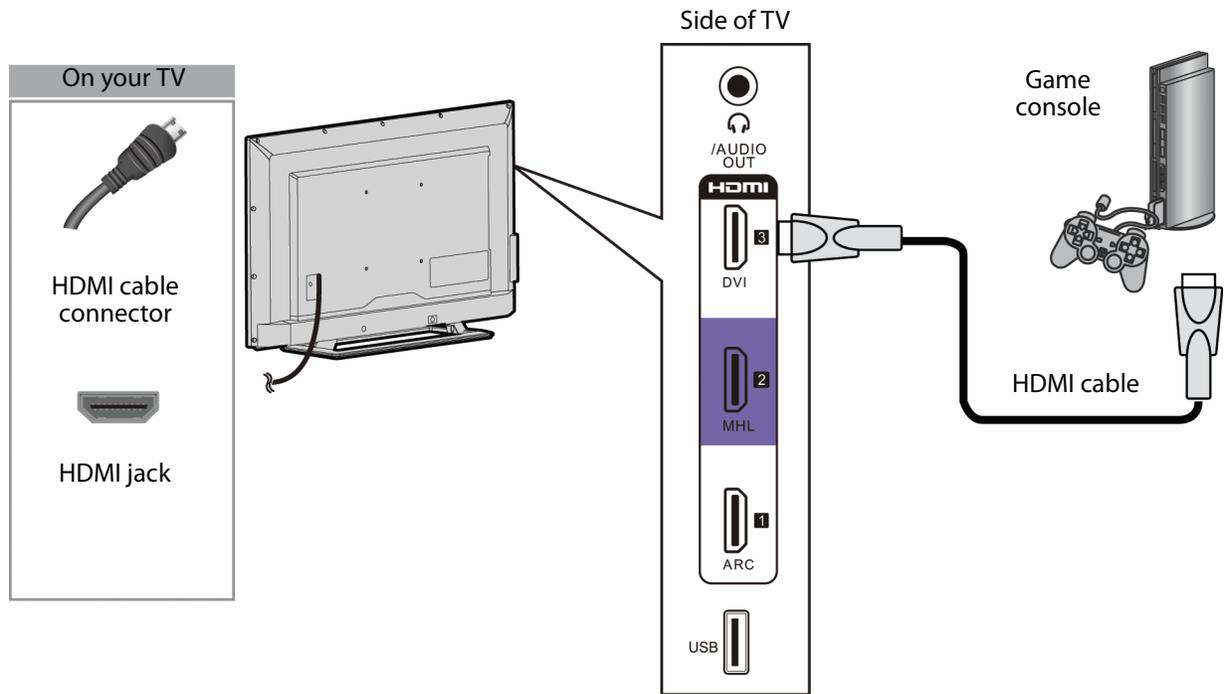

- 1 Make sure that your TV's power cord is unplugged and the game console is turned off.
- 2 Connect an HDMI cable (not provided) to one of the **HDMI** jacks on the side of your TV and to the **HDMI OUT** jack on the game console.
- 3 Plug your TV's power cord into a power outlet, then turn on your TV.
- 4 Turn on the game console, then set it to the correct output mode. For more information, see the documentation that came with the console.
- 5 Press **INPUT** to open the *INPUT SOURCE* list.
- 6 Press **▲** or **▼** to highlight **HDMI 1**, **HDMI 2**, or **HDMI 3**, then press **ENTER**.

Note

An HDMI cable carries both audio and video. You do not need to use any audio cables.

Component video (better)

Note
Cables are often color-coded to match color-coded jacks.

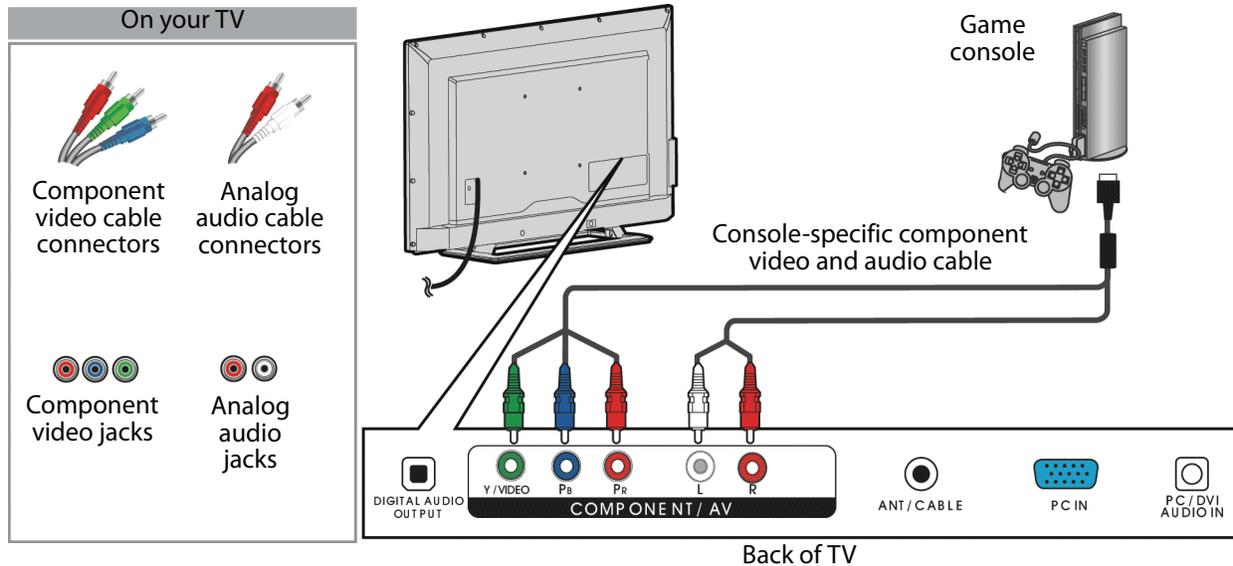

- 1 Make sure that your TV's power cord is unplugged and the game console is turned off.
- 2 Connect the video and audio connectors on the component video cable (not provided) to the **Y/VIDEO**, **Pb**, and **Pr** video jacks and **L** and **R** audio jacks on the back of your TV and to the component jack(s) on the game console.

Important

- Your game console may require a special component video cable. See the documentation that came with your game console or check the manufacturer's website.
- The **Y/VIDEO**, **Pb**, and **Pr** video jacks (used to connect a component video device) share the **L** and **R** audio jacks with the **Y/VIDEO** jack (used to connect an AV device). You can only connect one component video or AV device at a time. We suggest upgrading to HDMI if your game console supports it.
- When you connect the audio using the **L** and **R** audio jacks, the audio output is analog.

- 3 Plug your TV's power cord into a power outlet, then turn on your TV.
- 4 Turn on the game console, then set it to the correct output mode. For more information, see the documentation that came with the console.
- 5 Press **INPUT** to open the *INPUT SOURCE* list.
- 6 Press **▲** or **▼** to select **Component**, then press **ENTER**.

AV (composite video) (good)

Notes

- Cables are often color-coded to match color-coded jacks.
- The yellow video connector on the AV cable connects to the green **Y/VIDEO** jack.

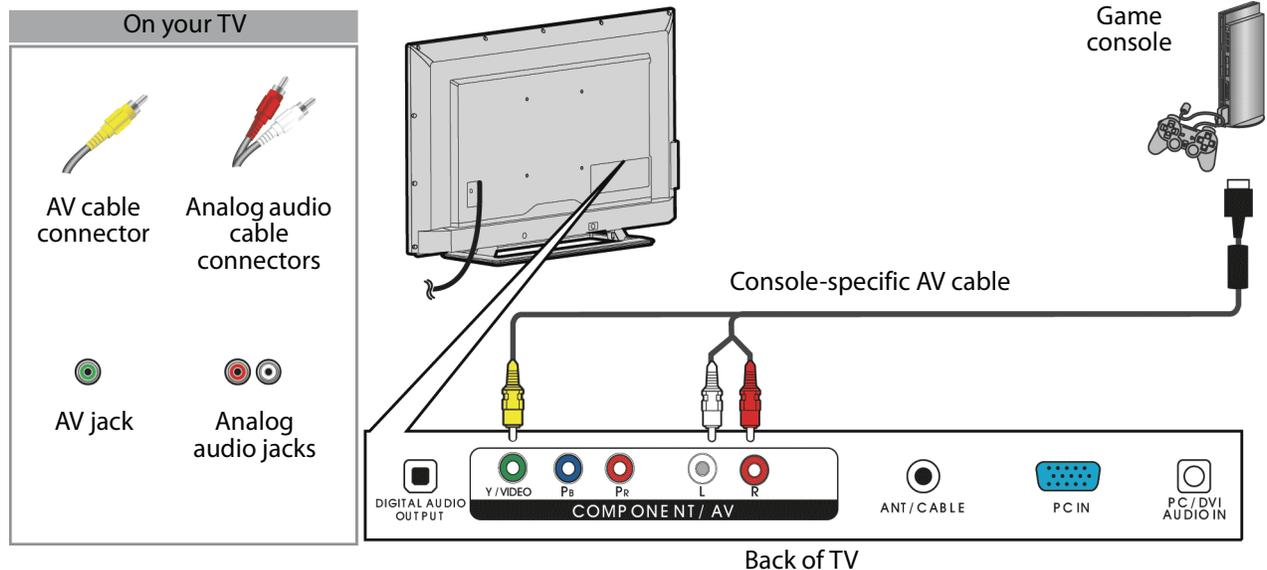

- 1 Make sure that your TV's power cord is unplugged and the game console is turned off.
- 2 Connect the video and audio connectors on the game console's AV cable (not provided) to the **Y/VIDEO** jack and **L** and **R** audio jacks on the back of your TV and to the composite jack(s) on the game console.

Important

- Most game consoles come with a special AV cable. See the documentation that came with your game console or check the manufacturer's Web site.
- The **Y/VIDEO**, **Pb**, and **Pr** video jacks (used to connect a component video device) share the **L** and **R** audio jacks with the **Y/VIDEO** jack (used to connect an AV device). You can only connect one component video or AV device at a time. We suggest upgrading to HDMI if your game console supports it.
- When you connect the audio using the **L** and **R** audio jacks, the audio output is analog.

- 3 Plug your TV's power cord into a power outlet, then turn on your TV.
- 4 Turn on the game console, then set it to the correct output mode. For more information, see the documentation that came with the console.
- 5 Press **INPUT** to open the *INPUT SOURCE* list.
- 6 Press **▲** or **▼** to select **AV**, then press **ENTER**.

Connecting a computer

HDMI (best)

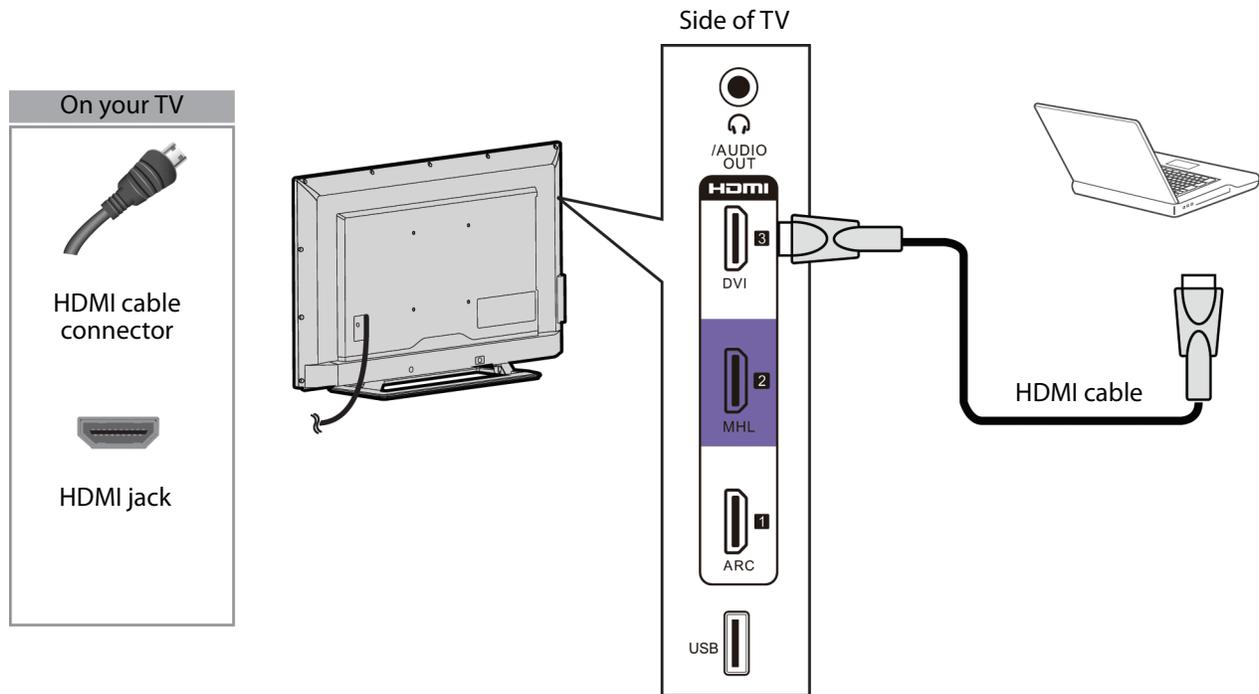

- 1 Make sure that your TV's power cord is unplugged and the computer is turned off.
- 2 Connect an HDMI cable (not provided) to one of the **HDMI** jacks on the side of your TV and to the **HDMI OUT** jack on the computer.
- 3 Plug your TV's power cord into a power outlet, then turn on your TV and the computer.
- 4 Press **INPUT** to open the *INPUT SOURCE* list.
- 5 Press **▲** or **▼** to highlight **HDMI 1**, **HDMI 2**, or **HDMI 3**, then press **ENTER**.
- 6 Adjust the display properties on the computer, if necessary.

DVI (same as HDMI but requires an audio connection)

Note

You must use the **HDMI 3/DVI** jack to connect a computer using DVI. If you use another HDMI jack, you will not hear sound from the TV speakers.

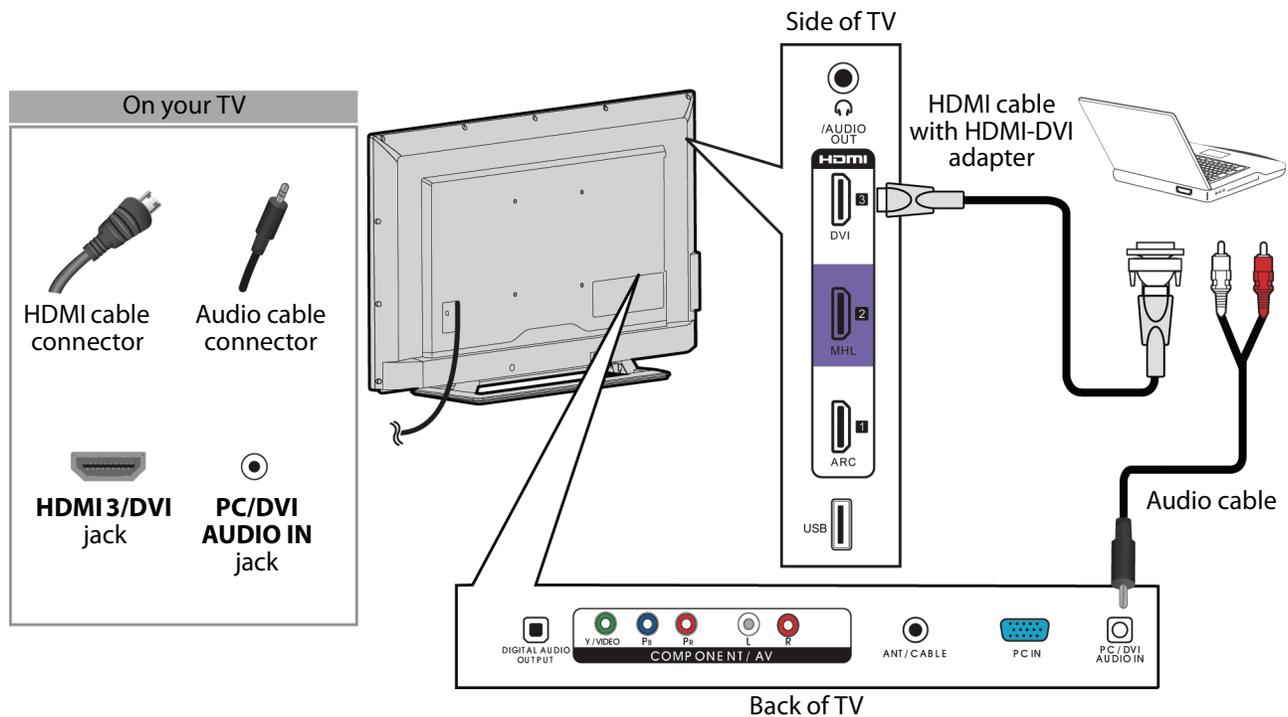

- 1 Make sure that your TV's power cord is unplugged and the computer is turned off.
- 2 Connect an HDMI-DVI adapter (not provided) to one end of an HDMI cable (not provided), then connect the adapter to the **DVI OUT** jack on the computer.
- 3 Connect the other end of the cable to the **HDMI 3/DVI** jack on the side of your TV.
- 4 Connect an audio cable (not provided) to the **PC/DVI AUDIO IN** jack on the back of your TV and to the **AUDIO OUT** (headphone) jack on the computer.

Note

When you connect the audio using the **PC/DVI AUDIO IN** jack, the audio output is analog.

- 5 Plug your TV's power cord into a power outlet, then turn on your TV and the computer.
- 6 Press **INPUT** to open the *INPUT SOURCE* list.
- 7 Press **▲** or **▼** to select **HDMI 3**, then press **ENTER**.
- 8 Adjust the display properties on the computer, if necessary.

VGA (most common)

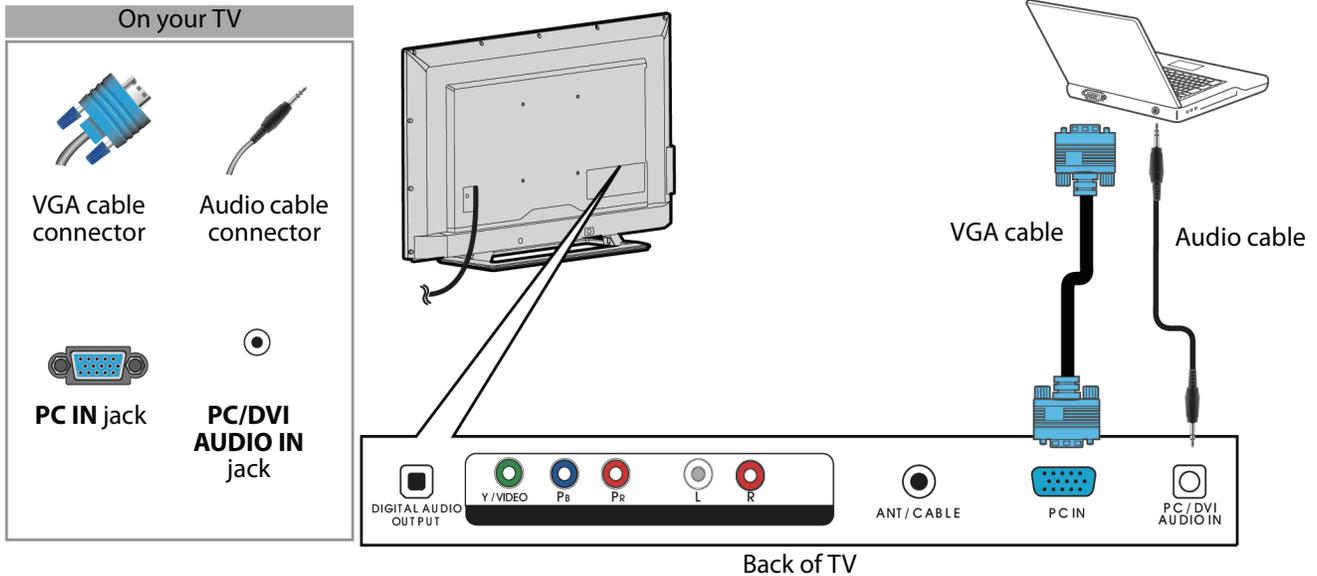

- 1 Make sure that your TV's power cord is unplugged and the computer is turned off.
- 2 Connect a VGA cable (not provided) to the **PC IN** jack on the back of your TV and to the **VGA** jack on the computer.
- 3 Connect an audio cable (not provided) to the **PC/DVI AUDIO IN** jack on the back of your TV and to the **AUDIO OUT** (headphone) jack on the computer.
- 4 Plug your TV's power cord into a power outlet, then turn on your TV and the computer.
- 5 Press **INPUT** to open the *INPUT SOURCE* list.
- 6 Press **▲** or **▼** to select **PC**, then press **ENTER**.
- 7 Adjust the display properties on the computer, if necessary.

Connecting a USB flash drive

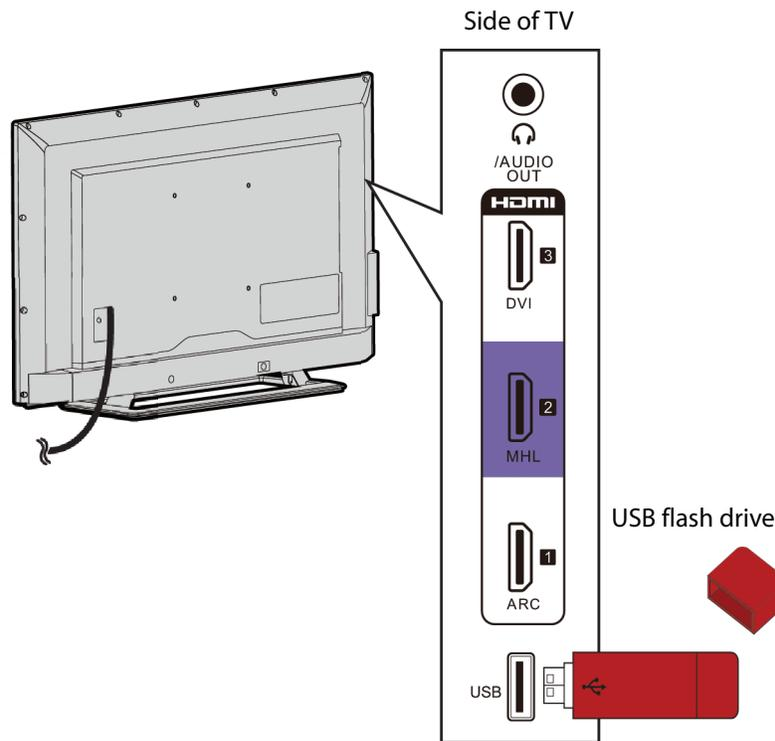

- 1 Plug a USB flash drive into the **USB** port on the side of your TV.

Caution

Do not remove the USB flash drive or turn off the TV while using the USB flash drive. You may lose data or damage the USB flash drive.

- 2 If your TV is turned on when you connect the USB flash drive, press **▲** or **▼** to select **Yes** in the message that appears, then press **ENTER**. The *PHOTOS* menu opens.

OR

If you switch to a different video input source after you plug in the USB flash drive and want to switch back to the drive, press **INPUT** to open the *INPUT SOURCE* list, press **▲** or **▼** to select **USB (Photos)**, then press **ENTER**. The *PHOTOS* menu opens.

Note

The **PHOTOS** viewer only supports JPEG format images (with “.jpg” file extensions) and not all JPEG files are compatible with your TV.
For more information, see [“Using a USB flash drive”](#) on page 50.

Connecting headphones

When you connect headphones, the TV speakers are muted.

Warning

Loud noise can damage your hearing. When using headphones, use the lowest volume setting on your headphones that still lets you hear the sound.

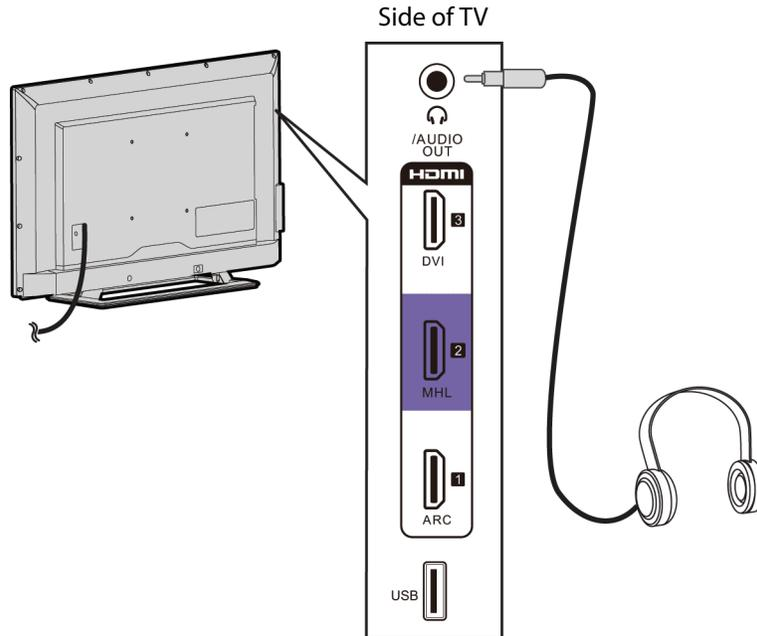

- 1 Connect the headphones to the /AUDIO OUT jack on the side of your TV.
- 2 In the screen that opens, press  or  to highlight **Headphones/Audio Out**, then press **ENTER**. For more information, see ["Selecting the audio out mode"](#) on page 56.

Notes

- If you connect headphones when your TV is turned off, then you turn on your TV, the TV speakers are muted and the audio plays through the headphones.
- You can also connect an amplifier, home theater system, or sound bar to the /AUDIO OUT jack. If you want to connect an amplifier, home theater system, or sound bar, you need to disconnect the headphones.

Connecting external speakers or a sound bar

You can connect external speakers or a sound bar to the digital audio jack.

Digital audio

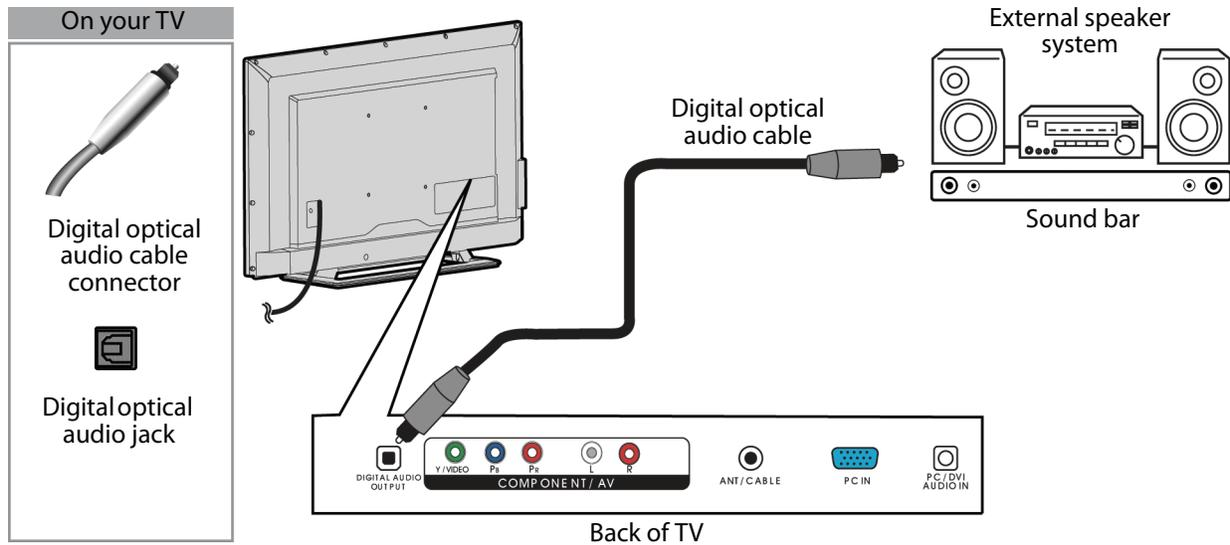

- 1 Make sure that your TV's power cord is unplugged and the external speaker system or sound bar is turned off.
- 2 Connect a digital optical audio cable (not provided) to the **DIGITAL AUDIO OUTPUT** jack on the back of your TV and to the optical **AUDIO IN** jack on the external speaker system or sound bar.
- 3 Plug your TV's power cord into a power outlet, then turn on your TV.
- 4 Turn on the external speaker system or sound bar, then set it to the correct source. For more information, see the documentation that came with the external speaker system or sound bar.
- 5 On your TV, highlight the **Digital Audio Format/Audio Delay** option on the *Sound* menu, then press **ENTER**. Set the **Audio Format** option to **PCM**. See "[Adjusting sound settings](#)" on page 55.

Analog audio

When you connect external speakers or a sound bar to the  **AUDIO OUT** jack, the TV speakers are muted.

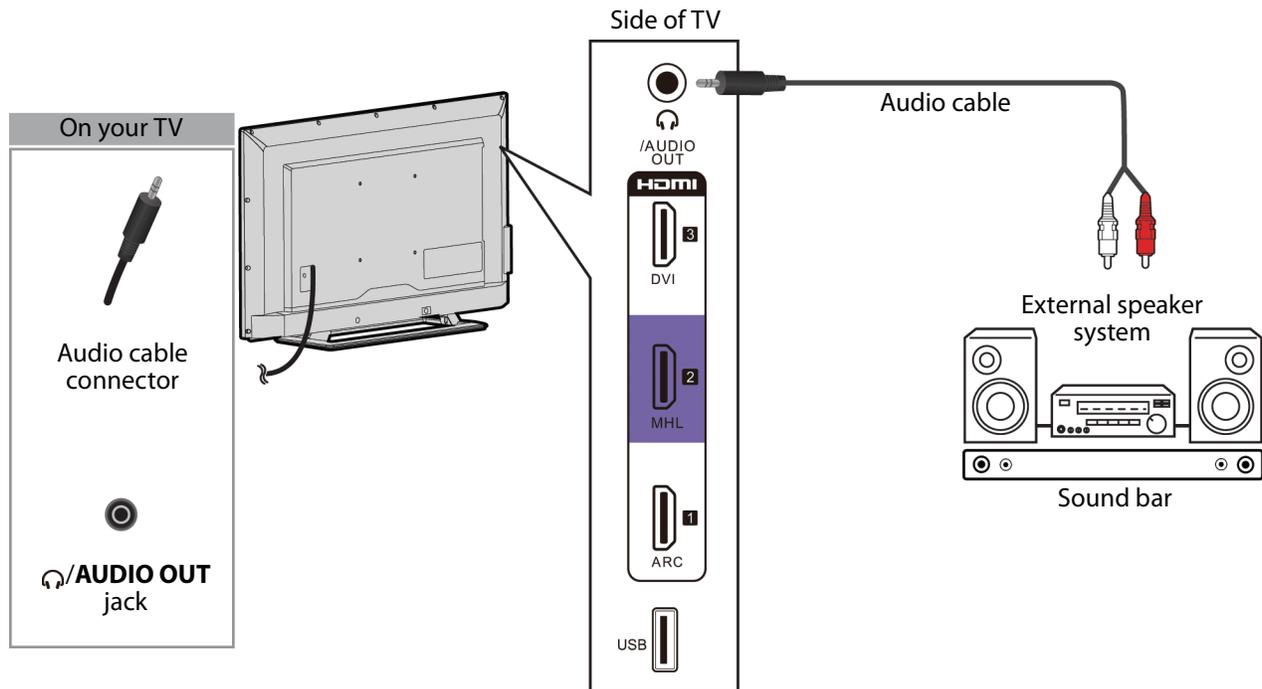

- 1 Make sure that your TV's power cord is unplugged and the external speaker system or sound bar is turned off.
- 2 Connect an audio cable (not provided) to the  **AUDIO OUT** jack on the side of your TV and to the **AUDIO IN** jacks on the external speaker system or sound bar.
- 3 Plug your TV's power cord into a power outlet, then turn on your TV.
- 4 Turn on the external speaker system or sound bar, then set it to the correct source. For more information, see the documentation that came with the external speaker system or sound bar.

Notes

- For information about selecting the audio out mode for an external speaker system or sound bar, see the **Headphones/Audio Out** option in "[Adjusting sound settings](#)" on page 55.
- You can connect headphones to the  **AUDIO OUT** jack. If you want to use headphones, you need to disconnect the external speaker system or sound bar.

Connecting a home theater system with multiple devices

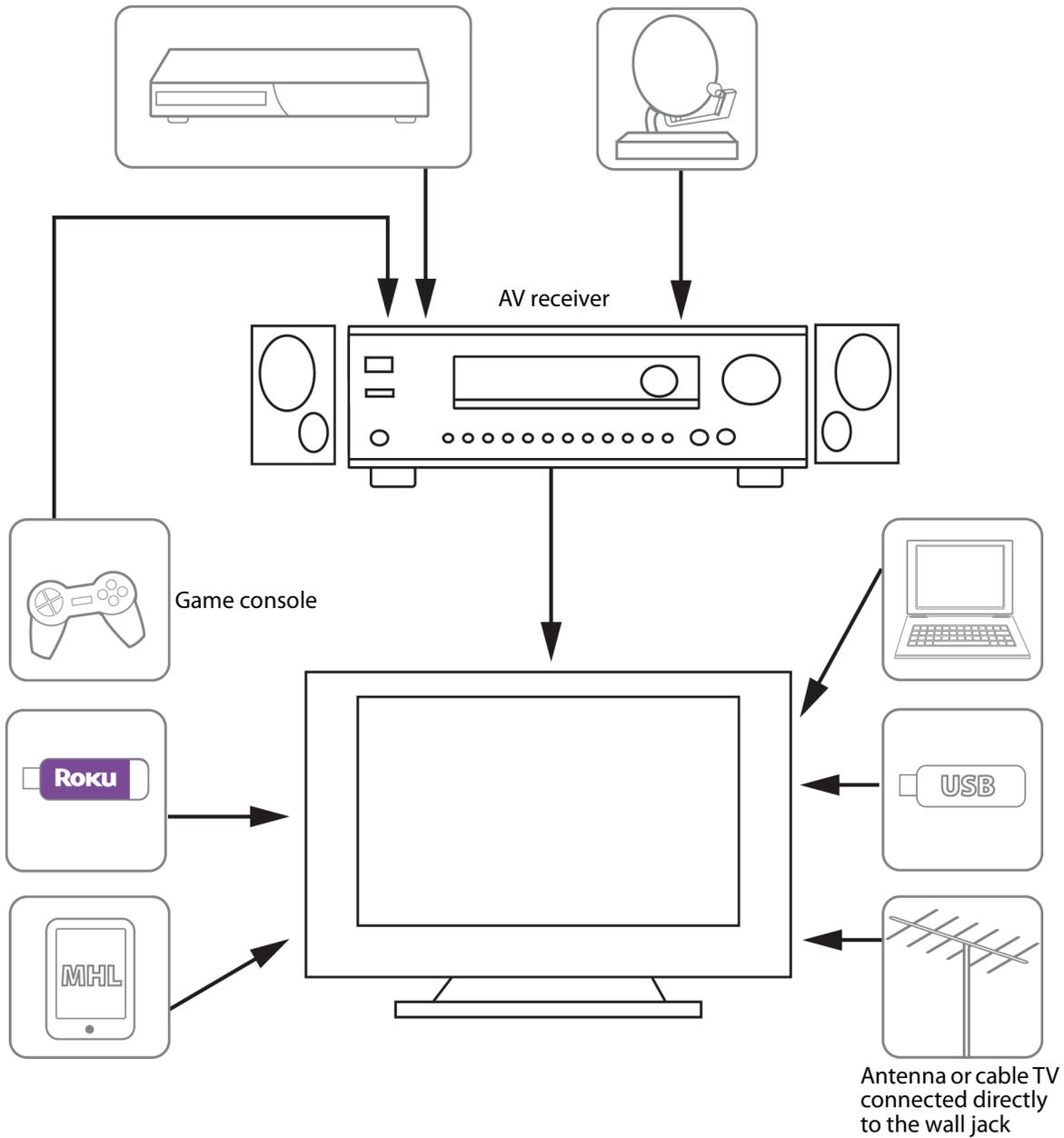

The connections you make depend on the video and audio jacks available on your devices. Refer to the documentation that came with your devices for connection information.

Just remember to use the best connection types available for the best picture and sound. For information about connection types, see ["What connection should I use?"](#) on page 14.

Connecting power

42-inch model

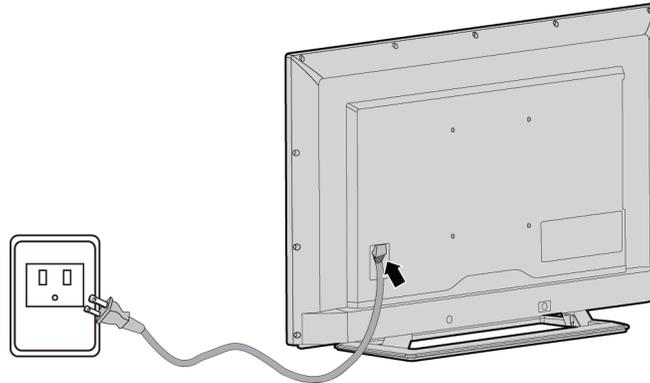

50-inch model

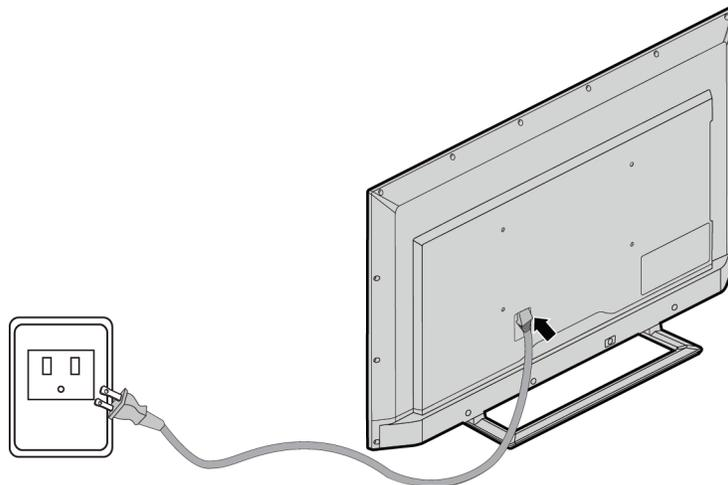

- 1 Connect the AC power cord to the AC IN connector on the back of your TV.
- 2 Connect the other end of the cord to a power outlet.

Caution

- Your TV should only be operated from the power source indicated on the label.
- Always unplug the AC power cord from the power outlet when you will not be using your TV for an extended period of time.

Using the remote control

Installing remote control batteries

- 1 While pressing the release latch on the back of the remote control, lift the battery compartment cover off of the remote control.

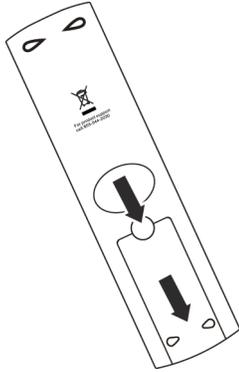

- 2 Insert two AAA batteries into the battery compartment. Make sure that you match the + and – symbols on the batteries with the + and – symbols in the battery compartment.

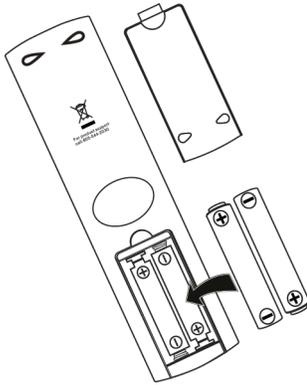

- 3 Replace the battery compartment cover.

Cautions

- Batteries should not be exposed to excessive heat, such as sunshine, heat registers, or fire.
- Battery chemicals can cause a rash. If the batteries leak, clean the battery compartment with a cloth. If chemicals touch your skin, wash immediately.
- Make sure that batteries are disposed of correctly. Do not burn or incinerate.

Notes

- Do not mix batteries of different types.
- Do not mix old and new batteries.
- Remove batteries when the charge is depleted.
- If the remote control is not going to be used for an extended period of time, remove the batteries.

Aiming the remote control

- Point the remote control towards the remote sensor on the front of your TV. For the location of the remote sensor, see "Front" on page 10.

Programming universal remote controls

You can operate your Sharp TV with a new or existing universal remote control.

- 1 See the table in "[Viewing universal remote control codes](#)" for common codes. If you have problems programming your remote or need a different remote control code, see the instructions that came with the remote control or check the remote control manufacturer's website for the latest remote control code information.
- 2 Follow your universal remote control's instructions to enter the TV code you found in Step 1.

Tips

- If your universal remote control has a code search feature, run a code search to identify a code that matches your TV. See your universal remote control's instructions for details.
- If your universal remote control has a "Learn" feature, you can manually program it using the Sharp TV remote to "teach" the commands one at a time. See your universal remote control's instructions for details.

For additional help and information:

- Visit the remote control manufacturer's website
- Call technical support for the universal remote control or cable/satellite company of the remote/set-top box you are trying to program.

Viewing universal remote control codes

You can view a list of universal remote control codes in the on-screen menu.

Tips

- The brand name is often visible on the front of the universal remote control, and the model number is often visible on the back.
- If your universal remote control is not listed, refer to your universal remote control's instructions and try codes for the brands Orion, Emerson, Memorex, Sansui, Sylvania, or Zenith. You may need to try several codes before finding a match.

- 1 Press **MENU**.



- 2 Press **◀** or **▶** to highlight **Help**, then press **ENTER**.

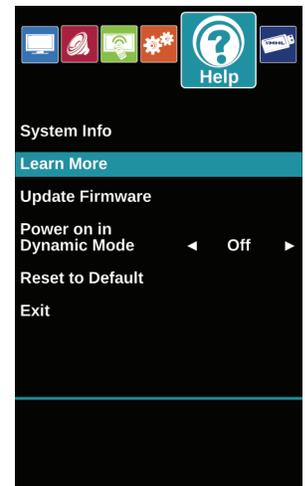

- 3 Press **▲** or **▼** to highlight **Learn More**, then press **ENTER** or **▶**.
- 4 Press **▲** or **▼** to highlight **Remote control codes**, then press **ENTER** or **▶**. Your TV displays information about the universal remote codes that you can use to make your TV work with a universal remote.
- 5 Press **ENTER** to view a list of available codes.

Turning on your TV for the first time

The first time you turn on your TV, the *Easy Setup* wizard opens. The wizard guides you through setting up basic settings.

- 1 Make sure that you have:
 - Installed the remote control batteries. (See page 38 for details.)
 - Connected an antenna, cable TV, or satellite TV. (See page 15 through 20 for details.)
 - Connected the power cord. (See page 37 for details.)
- 2 Press ⏻ (power) to turn on your TV.



- 3 Press \blacktriangle or \blacktriangledown to highlight a language, then press **ENTER**.

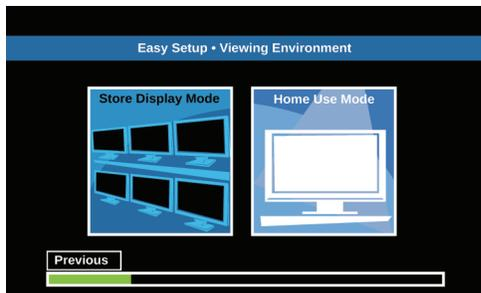

- 4 Press \blacktriangleleft or \blacktriangleright to highlight **Home Use Mode** or **Store Display Mode**, then press **ENTER**.

If you selected **Store Display Mode**, a message asks if you are sure you want this mode. Select **OK** to continue using **Store Display Mode**, or select **Cancel** to change to **Home Use Mode**, then press **ENTER**. **Store Display Mode** is not an energy savings mode.



- 5 Press \blacktriangleleft or \blacktriangleright to highlight an option, then press **ENTER**. You can select:
 - **Watch TV** to skip the customization options. You can press **MENU** later to access the on-screen menus and customize viewing settings. Go to "Finish the wizard" on page 41.
 - **Customize TV** to set viewing options to maximize your viewing experience. Go to "Customize my TV" on page 40.

Customize my TV

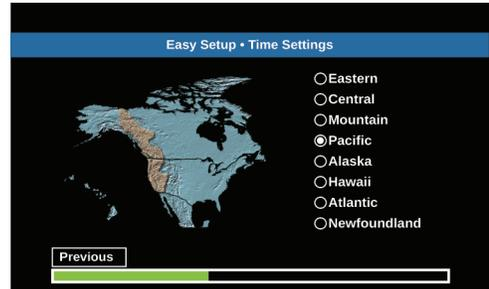

- 6 Press \blacktriangle or \blacktriangledown to highlight a time zone, then press **ENTER**.



- 7 Press \blacktriangle or \blacktriangledown to select **On** to turn on **Daylight Saving Time** or **Off** to turn off **Daylight Saving Time**, then press **ENTER**.

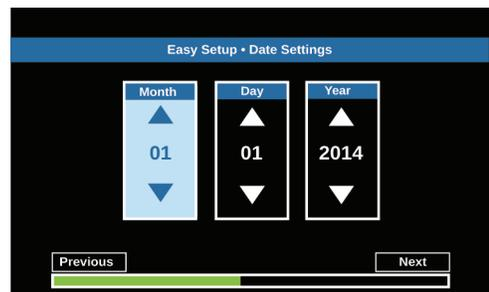

- 8 Press \blacktriangleleft or \blacktriangleright or **ENTER** to highlight **Month**, **Day**, or **Year**, then press \blacktriangle or \blacktriangledown to adjust the setting. When you are finished, use the arrow buttons to highlight **Next**, then press **ENTER**.

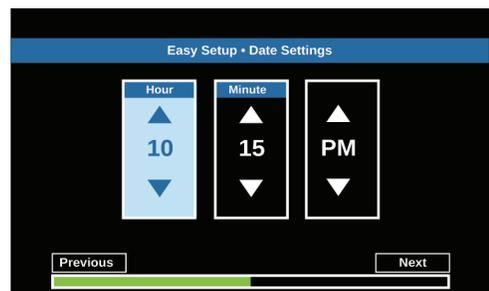

- 9 Press ◀▶ or **ENTER** to highlight **Hour, Minute**, or the **AM/PM** field, then press ▲ or ▼ adjust the option. When you are finished, use the arrow buttons to highlight **Next**, then press **ENTER**.

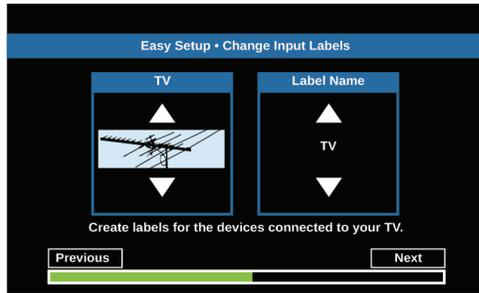

- 10 Press ▲ or ▼ to highlight a video input source, then press ▶ to move to the label area.

- 11 Press ▲ or ▼ to highlight a preset label or **Custom**.

- 12 If you select a preset label, press **ENTER**. The video input box on the left is selected so you can label a different video input source.

OR

If you select **Custom**, press **ENTER**, then press ▲ or ▼ to enter the first character in your custom label, then press ▶ to move to the next character position. Use the arrow buttons to enter additional characters or to move from character to character. You can enter 12 characters (letters or numbers). When you have finished creating your label, press **ENTER**. The video input box on the left is selected so you can label a different video input source.

- 13 Repeat Steps 10 through 12 to label additional video input sources.

- 14 When you have finished creating input labels, use the arrow buttons to highlight **Next**, then press **ENTER**.

Finish the wizard

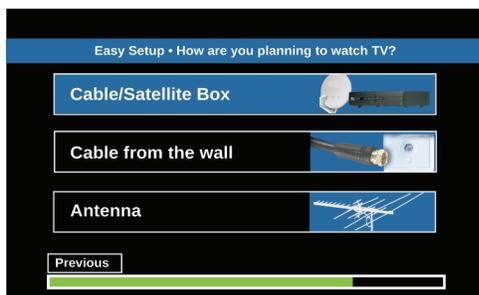

- 15 Press ▲ or ▼ to highlight **Cable/Satellite Box, Cable from the wall, or Antenna**, then press **ENTER**.

- If you select **Cable/Satellite Box**, a screen opens that shows you the ways you can connect the box.

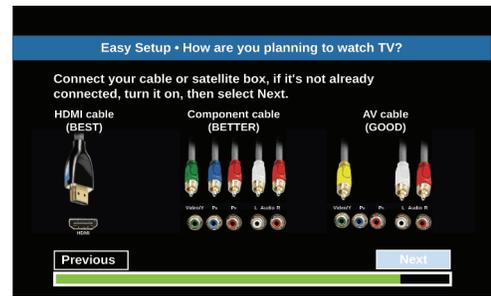

Press **ENTER**.

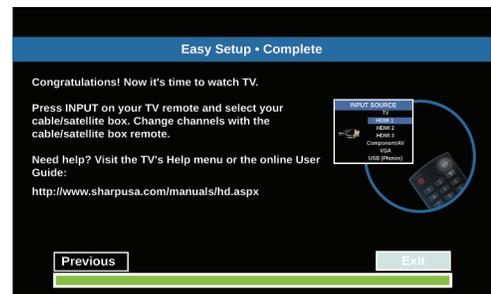

- If you select **Cable from the wall** or **Antenna**, your TV starts scanning for channels and displays a progress screen. The scan may take several minutes.

Note

You can press **EXIT**, or select **Skip** and press **ENTER**, to stop the auto channel search, but you will need to run the auto channel search again to create a channel list.

When a message tells you that setup is complete, press **ENTER** to close the menu.

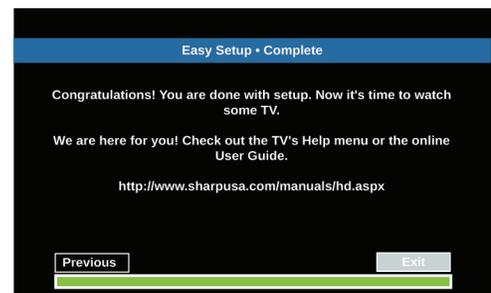

- 16 Press **ENTER** to close the wizard. If you selected:

- **Cable from the wall** or **Antenna**, your TV tunes to the first channel it found in the scan.
- **Cable/Satellite box**, press **INPUT** to open the **INPUT SOURCE** list, press ▲ or ▼ to select the video input (**HDMI**, **Component**, or **AV**) you connected the box to, then press **ENTER**. Your TV switches to the input you selected.

Understanding the basics

Turning your TV on or off

- 1 Make sure that the power cord is connected to a power outlet. See "Connecting power" on page 37.
- 2 Press **POWER** to turn on your TV. The power indicator turns blue.
- 3 Press **POWER** again to turn off your TV. Your TV enters standby mode, and the power indicator turns red.

Warning

When your TV is in standby mode, it is still receiving power. To completely disconnect power, unplug the power cord.

Note

If your TV does not receive an input signal for several minutes, it automatically goes into standby mode.

Selecting the video input source

- 1 Turn on your TV, then press **INPUT**.

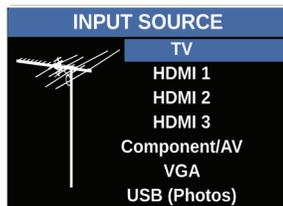

- 2 Press **▲** or **▼** to select a video input source, then press **ENTER**.

Note

The *INPUT SOURCE* list displays **Component** when a component video device is connected and turned on or displays **AV** when an AV device is connected and turned on.

On-screen menu overview

Notes

- Depending on the signal source selected, you may see different options on your screen.
- Menu items that are not selectable are grayed out.

Accessing the menus

- 1 Press **MENU**.



- 2 Press **◀** or **▶** to highlight a menu icon, then press **ENTER**.

Picture menu (TV mode)

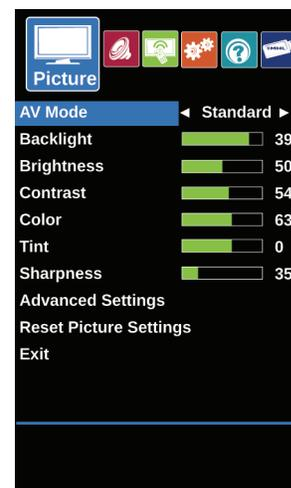

Sound menu (TV mode)

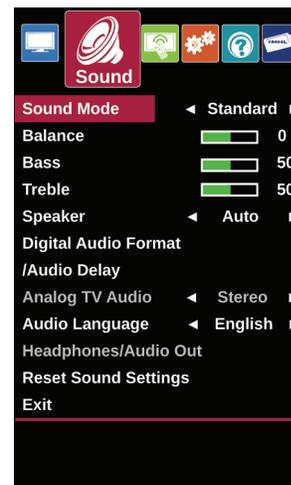

Channels menu (TV mode)

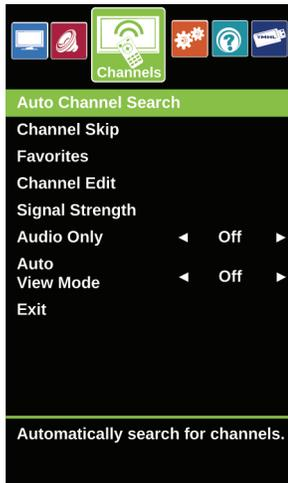

Help menu (TV mode)

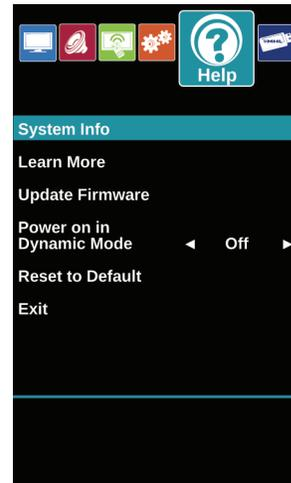

Settings menu (TV mode)

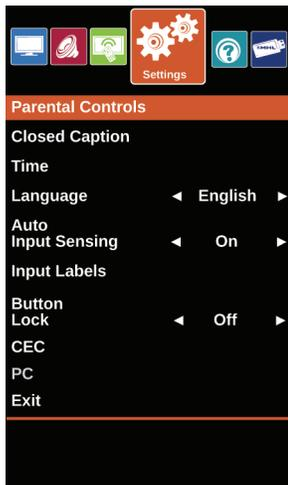

Photos menu (USB mode)



Navigating the menus

 Press **MENU** to open the on-screen menu.

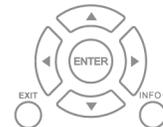

 Press the right or left arrow to move the cursor on the screen or to adjust a selected item.



 Press the up or down arrow to select menu options.



 Press **ENTER** to confirm a selection or enter a sub-menu.

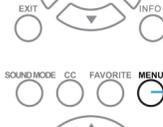

 Press **EXIT** to close the menu.

Selecting a channel

- Press **CH** \wedge or **CH** \vee to go to the next or previous channel on the memorized channel list.
- Press the number buttons to enter the channel number you want, then wait for the channel to change or press **ENTER** to immediately change the channel.
- To select a digital sub-channel, press the number buttons to enter the main digital channel, press \bullet (sub-channel), then press the number button for the sub-channel. Wait for the channel to change, or press **ENTER** to immediately change the channel. For example, to tune to channel 5.1, press **5**, \bullet (sub-channel), then **1**.

Note

Button presses must be within three seconds of each other.

- Press \curvearrowright **FLASHBACK** to go to the last viewed channel.
- Press **FAVORITE** to open the favorite channel list, press \blacktriangle or \blacktriangledown to highlight a channel, then press **ENTER**. For information about setting up a favorite channel list, see “[Setting up a favorite channel list](#)” on page 59.

Note

If a list has more than one page, press \blacktriangle or \blacktriangledown to scroll through the pages.

Adjusting the volume

- Press **VOL+** or **VOL-** to increase or decrease the volume.
- Press MUTE to turn off the sound.
Press MUTE again to turn the sound back on.

Viewing channel information

- Press **INFO*** to view an information banner. The information banner shows the current program information such as channel number, video input source, and resolution.
- Digital channel information—Displays the channel number, station name, channel label, broadcast program name, TV rating, signal type, audio information, resolution, current time, signal strength, day of the week, date and current program start and end times, if provided by the broadcaster.
- Analog channel information—Displays channel number, channel label, signal type, audio information, day of the week, date, and resolution, if provided by the broadcaster.

Using a Roku Streaming Stick

You can connect a Roku Streaming Stick and enjoy streaming video and audio.

Note

You must use the purple **HDMI 2/MHL** jack to connect a Roku Streaming Stick.

Connecting and using

- 1 Connect a Roku Streaming Stick™ to your TV. For connection instructions, see “[Connecting a Roku Streaming Stick](#)” on page 24. A message tells you the stick is connected.

Note

The message may take a few seconds to appear.

- 2 Press **ENTER** to access your Roku Streaming Stick™. Your stick’s menu opens.

Note

Your Roku Streaming Stick’s menu will vary depending on the content you have loaded on the device.

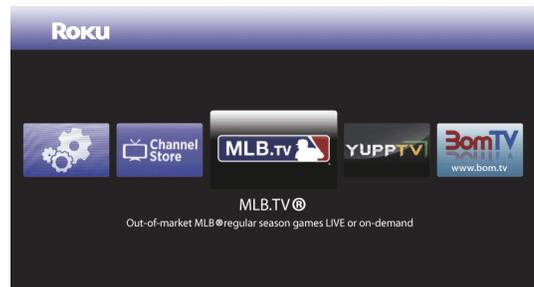

- 3 Use \blacktriangle \blacktriangledown \blacktriangleleft \blacktriangleright and **ENTER** to navigate on your Roku Streaming Stick™.

Switching back to the Roku Streaming Stick

- 1 Press **INPUT**, then press ▲ or ▼ to select **HDMI 2 (Roku)**.

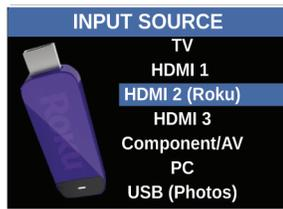

OR

Press **MENU**, then press ◀ or ▶ to highlight **Roku**.

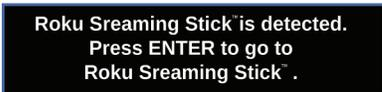

- 2 Press **ENTER** to access your Roku Streaming Stick™. Your stick's menu opens.

Note

Your Roku Streaming Stick's menu will vary depending on the content you have loaded on the device.

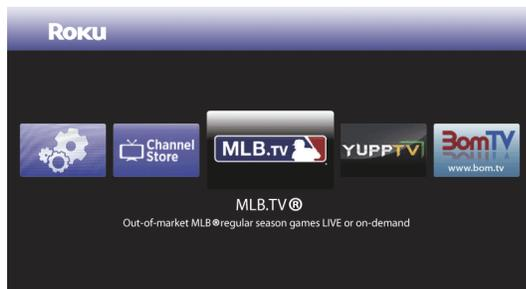

- 3 Use ▲ ▼ ◀ ▶ and **ENTER** to navigate on your Roku Streaming Stick™.

Using an MHL-enabled device

You can connect your MHL-enabled device, such as a cell phone, and view your device's screen on your TV.

Note

You must use the purple **HDMI 2/MHL** jack to connect an MHL-enabled device.

Connecting and using

- 1 Connect an MHL-enabled device to your TV. For connection instructions, see "[Connecting an MHL-enabled device](#)" on page 25. A message tells you the device is connected.
- 2 Press **ENTER** to access your MHL-enabled device. Your device's menu opens.

Note

Your device's menu will vary depending on the device and the apps you have loaded on the device.

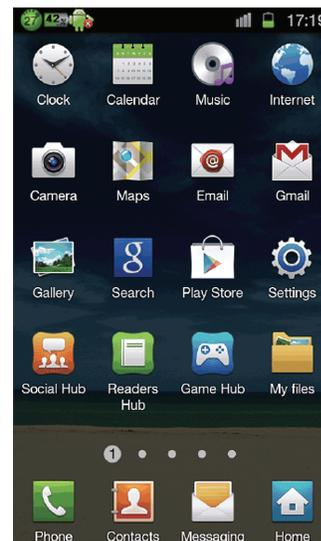

- 3 Use ▲ ▼ ◀ ▶ and **ENTER** to navigate on your device.

Note

The buttons you use to navigate on your device may vary depending on the device.

Switching back to the connected device

- 1 Press **INPUT**, then press **▲** or **▼** to select **HDMI 2 (MHL)**.

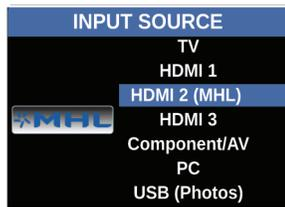

OR

Press **MENU**, then press **◀** or **▶** to highlight **MHL**.

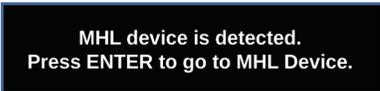

- 2 Press **ENTER** to access your MHL-enabled device. Your device's menu opens.

Note

Your device's menu will vary depending on the device and the apps you have loaded on the device.

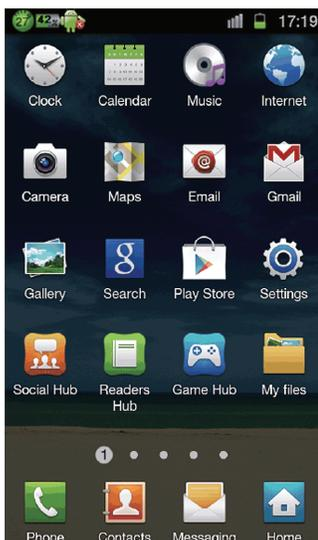

- 3 Use **▲ ▼ ◀ ▶** and **ENTER** to navigate on your device.

Note

The buttons you use to navigate on your device may vary depending on the device.

Using CEC Control

CEC Control lets you control HDMI CEC-compatible devices connected to the HDMI jacks on your TV using the remote control that came with your TV. To use CEC Control, you must set the **CEC Control** setting on the *Settings* · *CEC* menu to **On**.

Notes

- HDMI cables must be used to connect HDMI CEC-compatible devices to your TV.
- The connected device's HDMI CEC feature must be turned on.
- If you connect an HDMI device that is not HDMI CEC-compatible, all of the **CEC** features do not work.
- Depending on the connected HDMI device, the **CEC** feature may not work.

Turning CEC Control on or off

- 1 Press **MENU**.



- 2 Press **◀** or **▶** to highlight **Settings**, then press **ENTER**.

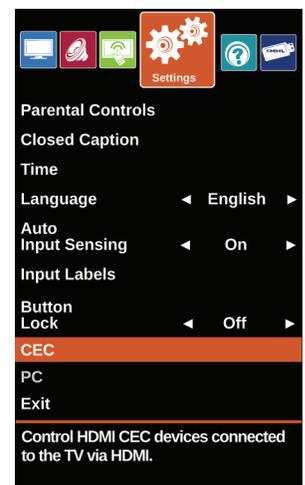

- 3 Press **▲** or **▼** to highlight **CEC**, then press **ENTER**.

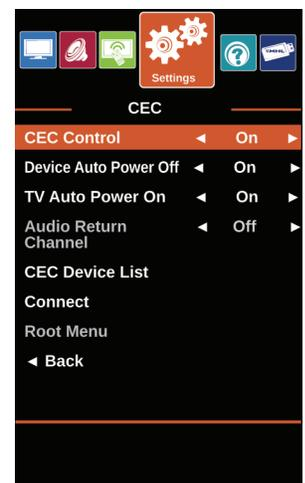

- 4 Press **▲** or **▼** to highlight **CEC Control**, then press **ENTER** or **▶** to access the option.
- 5 Press **◀** or **▶** to highlight **On** or **Off**, then press **ENTER**.
- 6 Press **MENU** to return to the previous menu, or press **EXIT** to close the menu.

Turning Device Auto Power Off on or off

When CEC Control is set to **On**, **Device Auto Power Off** automatically turns off HDMI CEC devices when you turn off your TV.

- 1 Press **MENU**.



- 2 Press **◀** or **▶** to highlight **Settings**, then press **ENTER**.

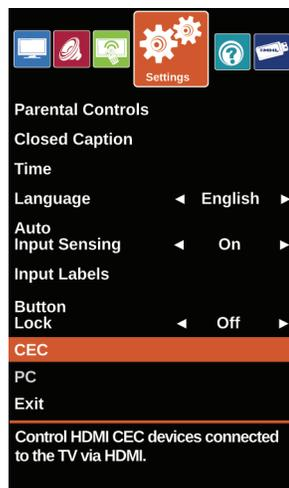

- 3 Press **▲** or **▼** to highlight **CEC**, then press **ENTER**.

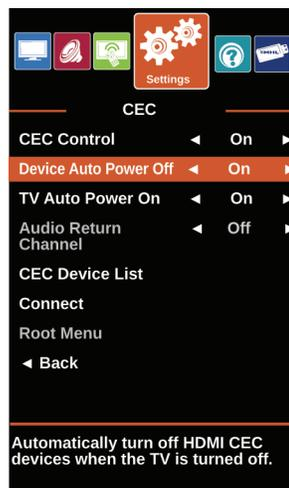

- 4 Make sure that the **CEC Control** option is turned on. See "Turning CEC Control on or off" on page 46.
- 5 On the *Settings · CEC* menu, press **▲** or **▼** to highlight **Device Auto Power Off**, then press **ENTER** or **▶** to access the option.

- 6 Press **◀** or **▶** to highlight **On** (turns off the connected devices when you turn off your TV) or **Off** (does not turn off the connected devices when you turn off your TV), then press **ENTER**.
- 7 Press **MENU** to return to the previous menu, or press **EXIT** to close the menu.

Turning TV Auto Power On on or off

TV Auto Power On automatically turns on your TV when an HDMI CEC device is turned on, if the device has this feature.

- 1 Press **MENU**.



- 2 Press **◀** or **▶** to highlight **Settings**, then press **ENTER**.

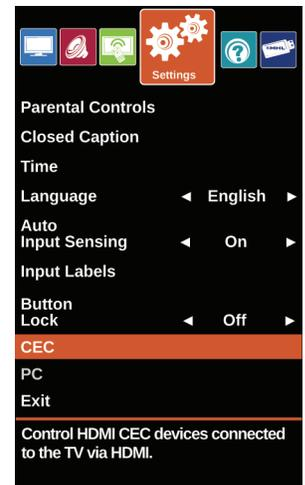

- 3 Press **▲** or **▼** to highlight **CEC**, then press **ENTER**.

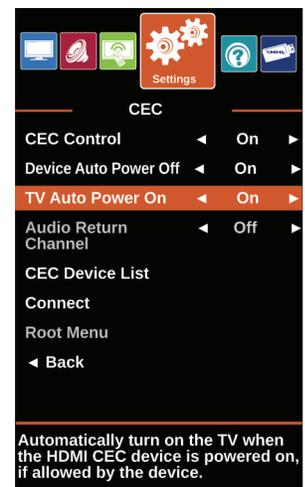

- 4 Make sure that the **CEC Control** option is turned on. See "Turning CEC Control on or off" on page 46.
- 5 On the *Settings · CEC* menu, press **▲** or **▼** to highlight **TV Auto Power On**, then press **ENTER** or **▶** to access the option.

- Press **◀** or **▶** to highlight **On** (turns on your TV when you turn on the connected device) or **Off** (does not turn on your TV when you turn on the connected device), then press **ENTER**.
- Press **MENU** to return to the previous menu, or press **EXIT** to close the menu.

Turning Audio Return Channel on or off

When CEC Control is turned on and you have connected an audio receiver to your TV, turning on **Audio Return Channel** lets you use your TV's remote control to control the volume on the audio receiver.

- Press **MENU**.



- Press **◀** or **▶** to highlight **Settings**, then press **ENTER**.

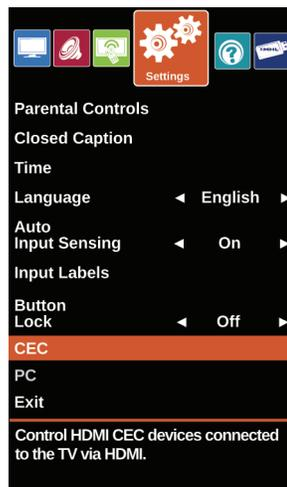

- Press **▲** or **▼** to highlight **CEC**, then press **ENTER**.

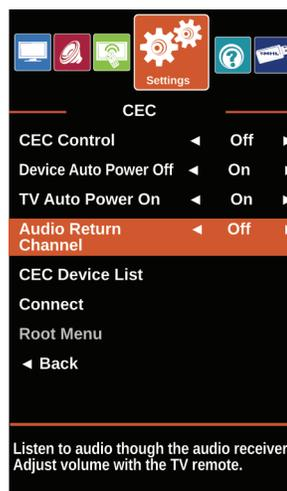

- Make sure that the **CEC Control** option is turned on. See ["Turning CEC Control on or off"](#) on page 46.
- On the *Settings* · *CEC* menu, press **▲** or **▼** to highlight **Audio Return Channel**, then press **ENTER** or **▶** to access the option.

- Press **◀** or **▶** to highlight **On** (your TV's remote control controls the connected audio receiver's volume) or **Off** (your TV's remote control does not control the connected audio receiver's volume), then press **ENTER**.
- Press **MENU** to return to the previous menu, or press **EXIT** to close the menu.

Displaying a list of CEC-compatible devices

You can display a list of HDMI CEC devices that are connected to your TV.

- Press **MENU**.



- Press **◀** or **▶** to highlight **Settings**, then press **ENTER**.

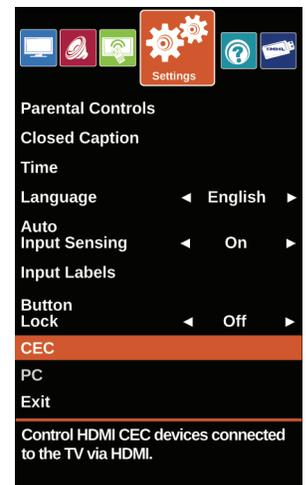

- Press **▲** or **▼** to highlight **CEC**, then press **ENTER**.

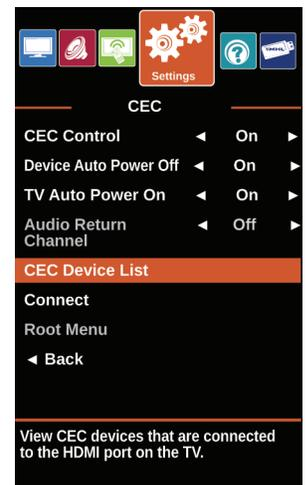

- Make sure that the **CEC Control** option is turned on. See ["Turning CEC Control on or off"](#) on page 46.
- On the *Settings* · *CEC* menu, press **▲** or **▼** to highlight **CEC Device Lists**, then press **ENTER**. A list of the HDMI CEC-compatible devices you have connected appears.
- Press **MENU** to return to the previous menu, or press **EXIT** to close the menu.

Selecting a CEC-compatible device

When you have more than one INLink-compatible device connected, you can select the device you want to use.

- 1 Press **INPUT**, press **▲** or **▼** to highlight the CEC-compatible device you want to wake, then press **ENTER**.
- 2 Press **MENU**.



- 3 Press **◀** or **▶** to highlight **Settings**, then press **ENTER**.

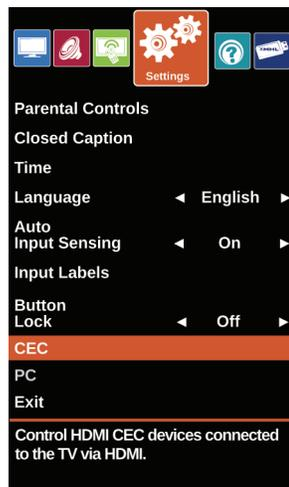

- 4 Press **▲** or **▼** to highlight **CEC**, then press **ENTER**.



- 5 Make sure that the **CEC Control** option is turned on. See ["Turning CEC Control on or off"](#) on page 46.
- 6 On the *Settings* · *CEC* menu, press **▲** or **▼** to highlight **Connect**, then press **ENTER**. A list of HDMI CEC-compatible devices you have connected opens.
- 7 Press **▲** or **▼** to highlight the HDMI CEC-compatible device you want to connect to, then press **ENTER**.
- 8 Press **MENU** to return to the previous menu, or press **EXIT** to close the menu.

Opening a CEC-compatible device's root menu

You can open a CEC-compatible device's root menu, then use your TV's remote control to control the device, if the device has this feature.

- 1 Press **INPUT**, press **▲** or **▼** to highlight an HDMI input, then press **ENTER**.
- 2 Press **MENU**.



- 3 Press **◀** or **▶** to highlight **Settings**, then press **ENTER**.

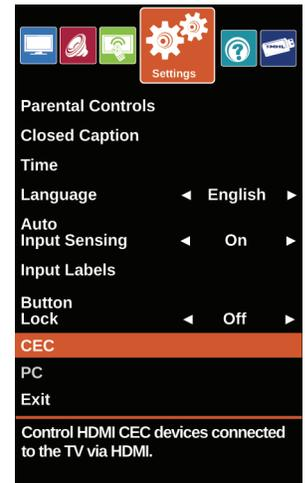

- 4 Press **▲** or **▼** to highlight **CEC**, then press **ENTER**.

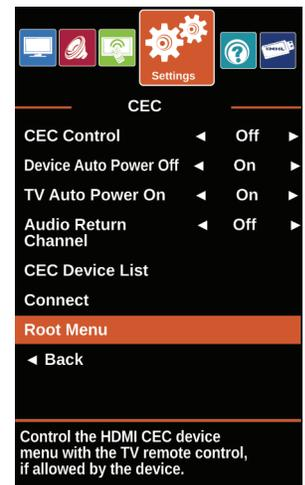

- 5 Make sure that the **CEC Control** option is turned on. See ["Turning CEC Control on or off"](#) on page 46.
- 6 On the *Settings* · *CEC* menu, press **▲** or **▼** to highlight **Root Menu**, then press **ENTER**. The device's root menu opens, and you can use your TV's remote control to control the device.
- 7 Press **MENU** to return to the previous menu, or press **EXIT** to close the menu.

Using a USB flash drive

You can connect a USB flash drive to your TV to view compatible JPEG pictures.

Notes

- Never remove the USB flash drive or turn off your TV while viewing JPEG pictures.
- The JPEG picture viewer only supports JPEG format images (with ".jpg" file extensions) and not all JPEG files are compatible with your TV.

Switching to USB mode

- 1 Make sure that you have connected the USB flash drive to the USB port on your TV.
- 2 If your TV is turned on when you connect the USB flash drive, press **▲** or **▼** to highlight **Yes** in the message that appears, then press **ENTER**. The *Photos* menu opens.

OR

If you connected the USB flash drive, then changed to a different video input source, press **INPUT** to open the *INPUT SOURCE* list, press **▲** or **▼** to highlight **USB (Photos)**, then press **ENTER**. The *Photos* menu opens.

Note

To exit USB mode, press **INPUT** to open the *INPUT SOURCE* list, then select another input source.

Browsing photos

- 1 Switch to USB mode. See "Switching to USB mode" on page 50.

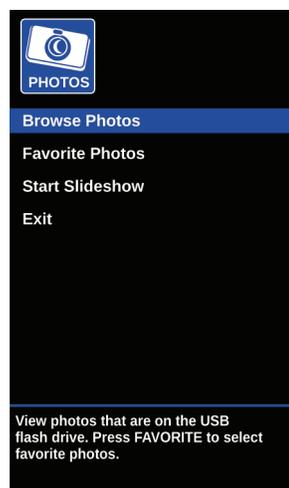

- 2 Press **▲** or **▼** to highlight **Browse Photos**, then press **ENTER**. The screen displays folder names and photo files stored on the USB flash drive in a thumbnail index with the first photo or folder highlighted. A control bar appears at the bottom of the screen.

Note

Photos are shown in the order they appear on the USB flash drive. They may not be listed in file name order.



- 3 To navigate the thumbnail index screen, press:
 - **▲ ▼ ◀ ▶** to browse through the files and folders.
 - **ENTER** to view a highlighted photo full-screen or open a highlighted folder.
 - **MENU** to open the *Photos* menu.
 - **FAVORITE** to add or remove a photo from the favorite photo list. A heart appears on a photo that has been added to the favorite photo list.

When a photo is displayed full-screen, a control bar appears at the bottom of the photo. The file name, picture resolution, size, and date are displayed on the bottom of the control bar. If you do not press a button within 10 seconds, the control bar closes. Press **INFO*** to open the control bar again.



- 4 To navigate on the photo screen, press:
 - **◀** to go to the previous photo.
 - **▶** to go to the next photo.
 - **ENTER** to rotate the photo clockwise.
 - **VIEW MODE** one or more times to enlarge the image by $\times 2$ or $\times 4$ or to select **Fill** (to fill the screen). You can press **▲ ▼ ◀ ▶** to pan the photo.
 - **EXIT** to return to the thumbnail index.
 - **MENU** to return to the *Photos* menu.

Viewing favorite photos

After you create your favorite photo list, you can browse among your favorite photos quickly.

- 1 Switch to USB mode. See [“Switching to USB mode”](#) on page 50.

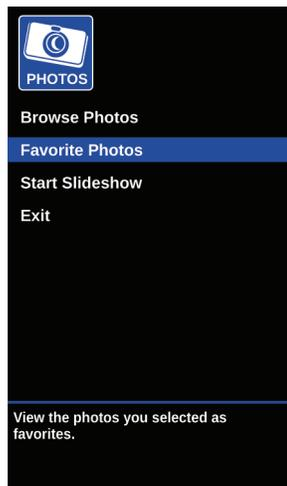

- 2 Press **▲** or **▼** to highlight **Favorite Photos**, then press **ENTER**. A thumbnail index of your favorite photos opens with a control bar at the bottom of the screen. A heart appears on a favorite photo.

Note

Photos are shown in the order they appear on the USB flash drive. They may not be listed in file name order.

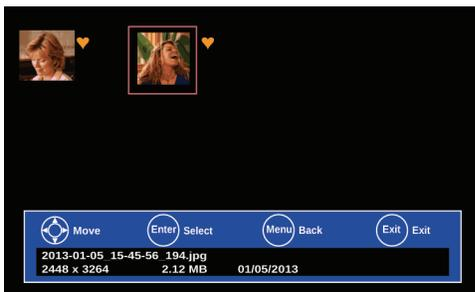

You select photos and navigate on the photo screen in the same way you do when you are browsing through photos. For more information, see [“Browsing photos”](#) on page 50.

Viewing photos in a slideshow

You can view your photos in a slideshow.

- 1 Switch to USB mode. See [“Switching to USB mode”](#) on page 50.
- 2 If the photos you want to view are in a folder on the USB flash drive, select the folder. For information about selecting a folder, see [“Browsing photos”](#) on page 50 or [“Viewing favorite photos”](#) on page 51.
- 3 Press **MENU**.

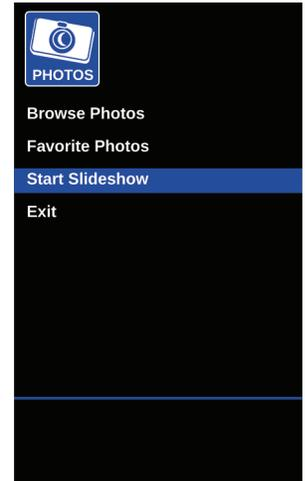

- 4 Press **▲** or **▼** to highlight **Start Slideshow**, then press **ENTER**. A slideshow starts with the first photo in the current folder.
- 5 To control the slideshow, press:
 - **ENTER**, **▶** (play), or **||** (pause) to pause or start the slideshow.
 - **EXIT** or **■** (stop) to exit the slideshow and go to the thumbnail index.
 - **MENU** to go to the *Photos* menu.

Adjusting the picture

Adjusting the TV picture

You can adjust various settings to improve the quality of the TV picture. Also, you can reset all picture settings to the factory default.

1 Press **MENU**.



2 Press ◀ or ▶ to highlight **Picture**, then press **ENTER**.



3 Press ▲ or ▼ to highlight an option, then press **ENTER** or ▶ to access the option. You can select:

- **AV Mode**—Selects the picture mode. You can select:
 - **Dynamic**—(a bright and vivid picture). Significantly increases the contrast, brightness, and sharpness. This selection is good for video games, animation, and in bright light environments.
 - **Natural**—(a standard picture). Moderately increases the contrast, brightness, and sharpness. This selection is good for standard TV broadcasts.
 - **Standard**—(the backlight brightness is decreased). Your TV has a backlight that provides light for displaying a picture. By reducing the amount of light, your TV uses less energy.
 - **Movie**—(a finely detailed picture). Adjusts the brightness and contrast and lowers the sharpness for a more realistic picture. This selection is good for watching the highest quality video such as Blu-ray Discs, DVDs, and HDTV.
 - **Game**—Adjusts the picture for the ultimate gaming experience. This option is available when the video input source is set the HDMI, Component, AV, or VGA.
 - **User**—(customized picture). Lets you manually adjust picture settings such as brightness, contrast, and sharpness.

Note

You can also press **AV MODE** to select the picture mode.

- **Backlight**—Sets the overall brilliance of the screen.
- **Brightness**—Adjusts the brightness of the dark areas of the picture.
- **Contrast**—Adjusts the brightness of the light areas of the picture.
- **Color**—Adjusts the color intensity of the picture. A low setting may make the color look faded. A high setting may make the color look artificial.
- **Tint**—Adjusts the color balance of the picture. Use this control to make skin tones look more natural.
- **Sharpness**—Adjusts the color detail of images. If you set this control too high, dark images may appear with light or white edges.
- **Advanced Settings**—Opens the *Advanced Settings* menu where you can adjust additional video options.

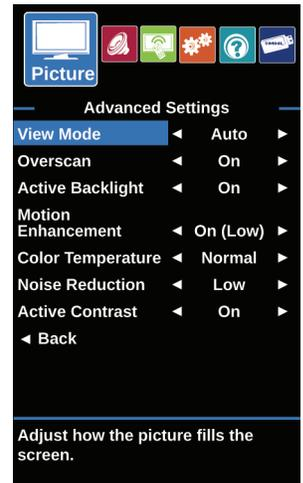

- **View Mode**—Adjusts how the picture fills the screen (aspect ratio). You can select:

Aspect ratio options	Example
Normal: Original aspect ratio is preserved. You might see black bars if the original content is not widescreen (16:9).	
Zoom: Expands the image to fill the screen. The top and bottom of the image may be cropped.	
Wide: Use this option to view content recorded in widescreen (16:9) format.	

Aspect ratio options	Example
<p>Cinema: Stretches the image at the edges, but keeps a clear image in the center.</p>	
<p>Auto: Automatically adjusts the image based on the screen size and the TV program. Select this option if you don't know which aspect ratio to choose.</p> <p>Note: Auto is only available when Auto View Mode in the <i>Channels</i> menu is set to On.</p>	

Note
You can also press **VIEW MODE** to select the aspect ratio.

- **Overscan**—Extends text and images past the screen edges to hide edge artifacts. You can select **On** or **Off**.
 - **Active Backlight**—Enhances the contrast ratio between light and dark areas of the picture. You can select **On** or **Off**.
 - **Motion Enhancement**—Reduces motion blur and eliminates film judder with clear detail and smooth motion. You can select **Off**, **On (Low)**, **On (High)**, or **Film Mode**.
 - **Color Temperature**—Selects the color temperature. You can select **Cool** (to enhance the blues), **Normal**, or **Warm** (to enhance the reds).
 - **Noise Reduction**—Selects the noise reduction mode to reduce picture noise (snow). You can select **Off**, **Low**, **Middle**, or **High**.
 - **Active Contrast**—Automatically adjusts picture detail and brightness. You can select **On** or **Off**.
 - **Reset Picture Settings**—Resets all picture settings to factory mode.
- 4 Press ◀ or ▶ to adjust the option.
 - 5 Press **MENU** to return to the previous menu, or press **EXIT** to close the menu.

Automatically adjusting the aspect ratio

Auto View Mode automatically changes how the picture looks on the screen (aspect ratio) based on the TV program you are viewing.

- 1 Press **MENU**.



- 2 Press ◀ or ▶ to highlight **Channels**, then press **ENTER**.

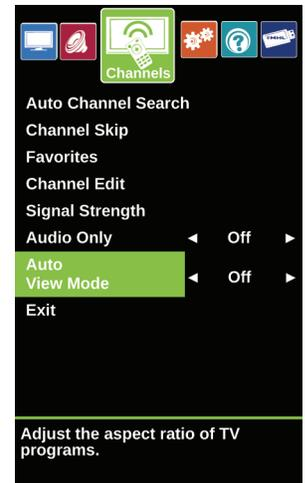

- 3 Press ▲ or ▼ to highlight **Auto View Mode**, then press **ENTER** or ▶ to access the option.
- 4 Press ◀ or ▶ to select **On** (automatically adjust the aspect ratio) or **Off** (does not automatically adjust the aspect ratio), then press **ENTER**.
- 5 Press **MENU** to return to the previous menu, or press **EXIT** to close the menu.

Note
You can also press **VIEW MODE** to select the aspect ratio.

Setting the power on picture mode

You can set the picture mode your TV uses when you turn it on.

- 1 Press **MENU**.



- 2 Press **◀** or **▶** to highlight **Help**, then press **ENTER**.

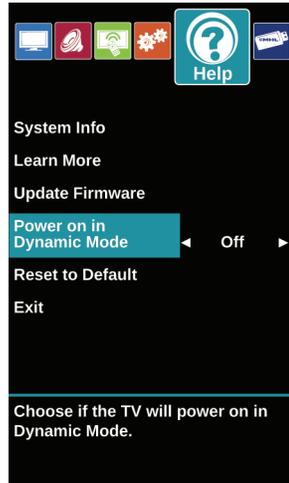

- 3 Press **▲** or **▼** to highlight **Power on in Dynamic Mode**, then press **ENTER** or **▶** to access the option.
- 4 Press **◀** or **▶** to select **On** (when you turn on your TV, it will be in **Dynamic** picture mode) or **Off** (when you turn on your TV, it will be in the picture mode it was in before you turned it off), then press **ENTER**.
- 5 Press **MENU** to return to the previous menu, or press **EXIT** to close the menu.

Adjusting the computer image

When you connect a computer to your TV using the **PC IN** jack, you may need to adjust the computer image to improve the quality.

Note

The **PC** option is only available when a computer is connected to the **PC IN** jack on the back of your TV.

- 1 Press **INPUT**, press **▲** or **▼** to highlight **PC**, then press **ENTER**.
- 2 Press **MENU**.



- 3 Press **◀** or **▶** to highlight **Settings**, then press **ENTER**.

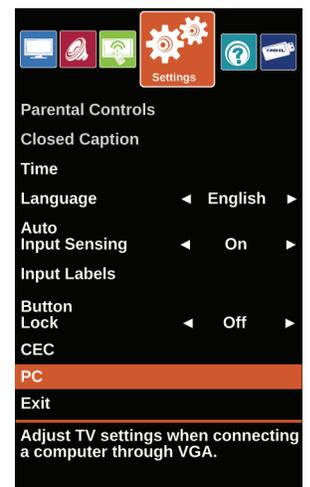

- 4 Press ▲ or ▼ to highlight **PC**, then press **ENTER**.

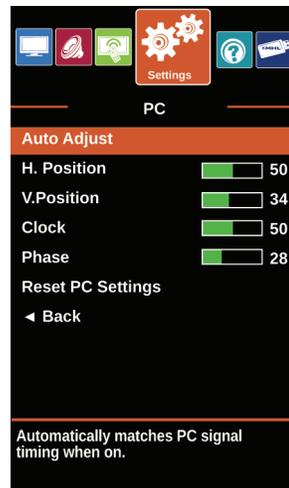

- 5 Press ▲ or ▼ to highlight an option, then press **ENTER** or ► to access the option. You can select:
- **Auto Adjust**—Automatically adjusts the image settings such as position and phase.
 - **H. Position**—Moves the image right or left.
 - **V. Position**—Moves the image up or down.
 - **Clock**—Minimizes vertical stripes in the screen image.
 - **Phase**—Adjusts the focus of stable images.
 - **Reset PC Settings**—Resets all computer settings to factory mode.
- 6 Press ◀ or ▶ to adjust the option.
- 7 Press **MENU** to return to the previous menu, or press **EXIT** to close the menu.

Adjusting the sound

Adjusting sound settings

You can adjust sound settings to improve the sound quality. You also can reset all sound settings to the factory default.

- 1 Press **MENU**,



- 2 Press ◀ or ▶ to highlight **Sound**, then press **ENTER**.

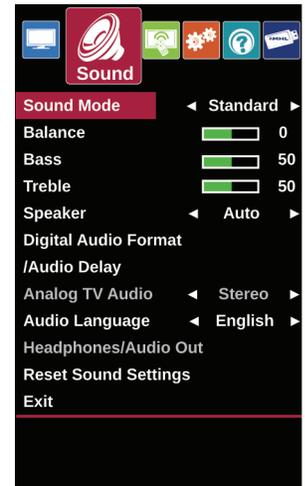

- 3 Press ▲ or ▼ to highlight an option, then press **ENTER** or ► to access the option. You can select:
- **Sound Mode**—Selects the sound mode. You can select:
 - **Standard**—Balances treble and bass. This setting is good for watching standard TV broadcasts.
 - **Movie**—Enhances treble and bass for a rich sound experience. This setting is good for watching DVDs, Blu-ray Discs, and HDTV.
 - **Music**—Preserves the original sound. This setting is good for listening to music.
 - **Voice**—Enhances vocals for TV audio. This setting is good for watching news broadcasts.
 - **User**—Lets you manually adjust sound settings.
 - **Balance**—Adjusts the balance between the left and right audio channels.
 - **Bass**—Adjusts the low sounds.
 - **Treble**—Adjusts the high sounds.
 - **Speaker**—Selects where to play TV audio. When you connect headphones to your TV, audio plays through both the headphones and the TV speakers. You can select:
 - **Auto** (default setting)—Automatically turns off the TV speakers when you connect a device to the ◻/AUDIO OUT jack. When the device is disconnected, the TV speakers turn on automatically.
 - **On**—Always plays the audio through the TV speakers. If a device is connected to the ◻/AUDIO OUT jack, the audio is played through both the TV speakers and the device.
 - **Off**—Turns off the TV speakers and plays the audio only through the device connected to the ◻/AUDIO OUT jack. If you disconnect the device, the TV speakers remain turned off.

- **Digital Audio Format/Audio Delay**—Sends digital audio to an external audio system. You can select:
 - **Audio Format**—Selects how the digital audio is sent to the external audio system. You can select:
 - **Pass Thru**—Outputs the original digital audio sound.
 - **PCM**—Outputs audio in 2-channel stereo.
 - **Audio Delay**—Fine tunes the audio when it is not in sync with the video.
- **Analog TV Audio**—(Analog channels only) Selects the audio mode. You can select:
 - **Mono**—Select this option if there is noise or static on weak stereo broadcasts.
 - **Stereo**—Select this option for programs broadcast in stereo.
 - **SAP**—Select this option to listen to a secondary audio program, if available.

Note

You can also press **AUDIO** one or more times to select the audio mode.

- **Audio Language**—(Digital channels only) Selects an alternate audio language, if available.
- **Headphones/Audio Out**—You can use the **Ⓜ/AUDIO OUT** jack on the side of your TV to connect headphones, a home theater system, or a sound bar. When a device is connected to the **Ⓜ/AUDIO OUT** jack, the TV speakers are muted. You can select:
 - **Headphones/Audio Out**—Select this option to use the remote control that came with your TV to control the audio from the headphones, home theater system, sound bar, or external speaker system you connected to the **Ⓜ/AUDIO OUT** jack.
 - **Audio Out Fixed**—Select this option to use the remote control that came with the home theater system, sound bar, or external speaker system you connected to the **Ⓜ/AUDIO OUT** jack to control the audio.

This option is only available when a device is connected to the **Ⓜ/AUDIO OUT** jack.

- **Reset Sound Settings**—Reset all audio settings to factory defaults.

- 4 Press **◀** or **▶** to adjust the option.
- 5 Press **MENU** to return to the previous menu, or press **EXIT** to close the menu.

Selecting the audio out mode

If your TV is on when you connect a device to the **Ⓜ/AUDIO OUT** jack on the side of your TV, a screen opens where you select which audio out mode you want to use.

- 1 Connect headphones, an amplifier, a home theater system, or a sound bar to the **Ⓜ/AUDIO OUT** jack on the side of your TV.



- 2 Press **◀** or **▶** to highlight the audio out mode you want to use, then press **ENTER**. You can select:
 - **Headphones/Audio Out**—Select this option to use the remote control that came with your TV to control the audio from the headphones, home theater system, sound bar, or external speaker system you connected to the **Ⓜ/AUDIO OUT** jack.
 - **Audio Out Fixed**—Select this option to use the remote control that came with the home theater system, sound bar, or external speaker system you connected to the **Ⓜ/AUDIO OUT** jack to control the audio.

Playing TV audio only

You can turn off the picture on your TV and listen to the program audio only.

- 1 Press **MENU**,



- 2 Press **◀** or **▶** to highlight **Channels**, then press **ENTER**.

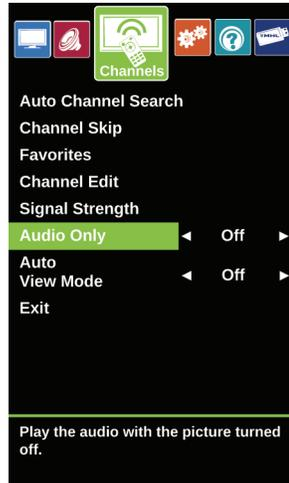

- 3 Press **▲** or **▼** to highlight **Audio Only**, then press **ENTER** or **▶** to access the option.
- 4 Press **◀** or **▶** to select **On**.
- 5 Press **MENU** to return to the previous menu, or press **EXIT** to close the menu.

Notes

- The picture turns off in about five seconds.
- **Audio Only** works only when the input source is TV and your TV is receiving a broadcast signal.
- To exit audio only mode, press any button. When you exit audio only mode, the **Audio Only** option is automatically reset to **Off**.

Changing channel settings

Automatically scanning for channels

When you scan for channels, your TV searches for channels with signals and stores the channel information in the channel list. When you press **CH ▲** or **CH ▼**, your TV goes to the next or previous channel in the channel list.

If the TV signal source changes, for example you change from an outdoor antenna to cable TV (no box), you need to scan for channels.

- 1 Press **MENU**.



- 2 Press **◀** or **▶** to highlight **Channels**, then press **ENTER**.

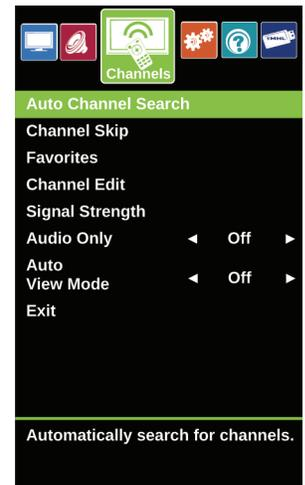

- 3 Press **▲** or **▼** to highlight **Auto Channel Search**, then press **ENTER**.

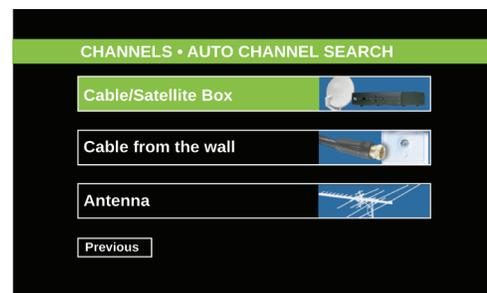

4 Press **▲** or **▼** to highlight **Cable/Satellite Box**, **Cable from the wall**, or **Antenna**, then press **ENTER**.

A If you select **Cable/Satellite Box**, a screen opens to show the ways you can connect a cable or satellite box.



Press **ENTER**. A message tells you that setup is complete. Press **ENTER** to close the menu.

B If you select **Cable from the wall**, your TV scans for channels. The scan may take several minutes. When a message tells you that setup is complete, press **ENTER** to close the menu.

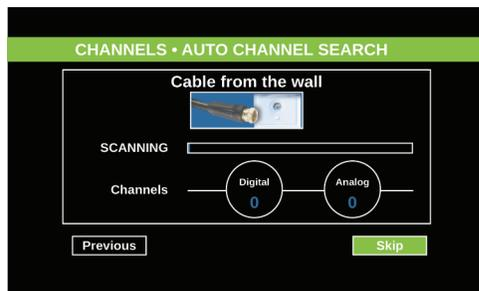

C If you select **Antenna**, your TV scans for available channels. The scan may take several minutes. When a message tells you that setup is complete, press **ENTER** to close the menu.

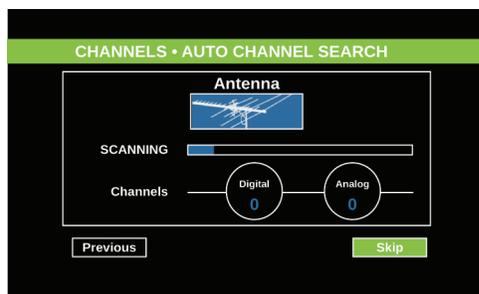

Note

You can press **EXIT** to stop the auto channel search, but you will need to run the auto channel search again to create a channel list.

Hiding channels

You can hide channels in the channel list. When you press **CH ▲** or **CH ▼**, your TV skips the hidden channels. You can still tune to a hidden channel by pressing the number buttons for the channel.

1 Press **MENU**.



2 Press **◀** or **▶** to highlight **Channels**, then press **ENTER**.

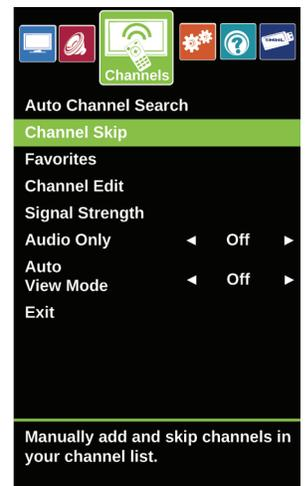

3 Press **▲** or **▼** to highlight **Channel Skip**, then press **ENTER** or **▶** to access the option.

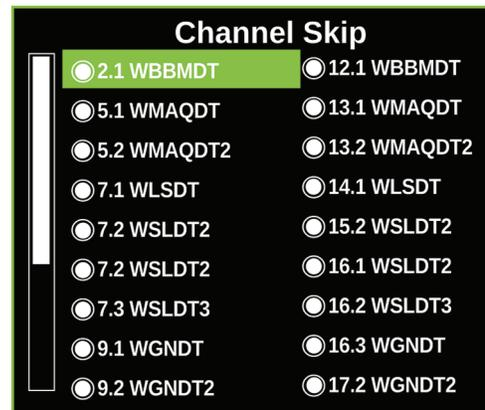

- Press **▲▼◀▶** to highlight the channel you want to hide, then press **ENTER**. Each channel has a circle to the left. When you hide a channel the circle is empty.

Notes

- If you highlight a channel in the list for two to four seconds, your TV displays the channel in the background.
- A channel with a filled circle is not hidden. A channel with an empty circle is hidden.
- If the list has more than one page, press **▲** or **▼** to scroll through the pages.

- Press **MENU** to return to the previous menu, or press **EXIT** to close the menu.

Setting up a favorite channel list

You can create a favorite channel list so you can quickly browse through your favorite channels by pressing **FAVORITE**, then selecting a channel from the favorite channel list.

- Press **MENU**.



- Press **◀** or **▶** to highlight **Channels**, then press **ENTER**.

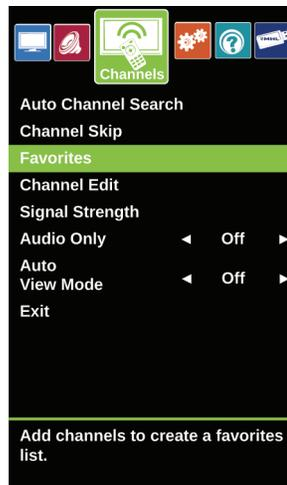

- Press **▲** or **▼** to highlight **Favorites**, then press **ENTER**.



- Press **▲▼◀▶** to highlight the channel you want to add to the favorites list, then press **ENTER**. Each channel has a circle to the left. When you add a channel to the *Favorite List*, the circle is filled.

Notes

- If you highlight a channel in the list for two to four seconds, your TV displays the channel in the background.
- To remove a channel from the favorites list, highlight the channel, then press **ENTER**. The filled circle is replaced with an empty circle and the channel is removed from the list.
- If the list has more than one page, press **▲** or **▼** to scroll through the pages.

- Press **MENU** to return to the previous menu, or press **EXIT** to close the menu.

Viewing a favorite channel

- Press **FAVORITE**.
- Press **▲** or **▼** to highlight a channel, then press **ENTER**.

Adding or changing a channel label

If a channel is not already labeled, you can label the channel to make it easier to identify. You can also relabel a channel that is already labeled.

- 1 Press **MENU**.



- 2 Press ◀ or ▶ to highlight **Channels**, then press **ENTER**.

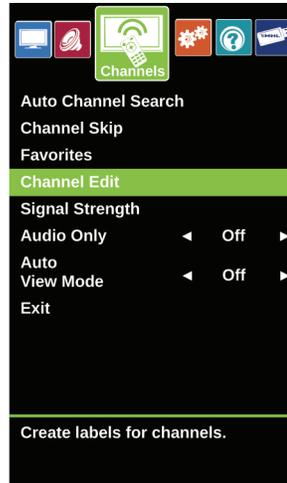

- 3 Press ▲ or ▼ to highlight **Channel Edit**, then press **ENTER**.

- 4 Press ◀ or ▶ to select the channel you want to label, then press ▼ to move to the channel label field. Do you press down arrow to go to the label field?



- 5 Press ▲ or ▼ to select a character, then press ◀ or ▶ to move to the previous or next character position. Repeat this step to enter additional characters. You can enter as many as 11 characters.

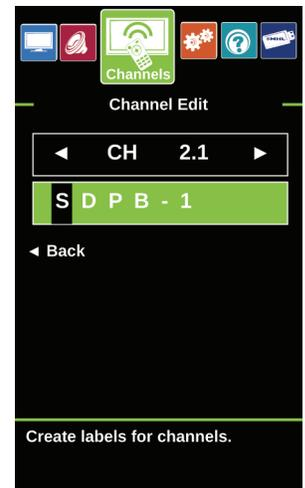

- 6 When you have completed the label, press **ENTER**.
- 7 Press **EXIT** to close the menu.

Checking the digital signal strength

You can check the digital signal strength to determine if you need to adjust your antenna or digital cable input. The higher the signal strength, the less likely you are to experience picture degradation.

- 1 Press **MENU**.



- 2 Press **◀** or **▶** to highlight **Channels**, then press **ENTER**.

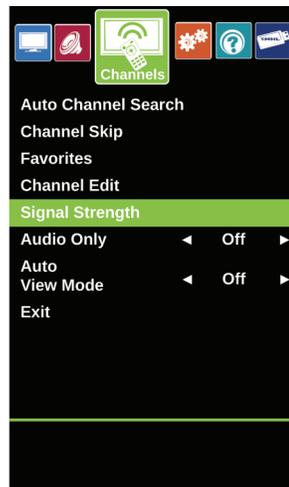

- 3 Press **▲** or **▼** to highlight **Signal Strength**, then press **ENTER**.



- 4 Press **MENU** to return to the previous menu, or press **EXIT** to close the menu.

Setting parental controls

Parental controls let you prevent your children from watching inappropriate material on TV. When set, parental controls read the rating of the program (with some exceptions, such as news and sports) and deny access to programs that exceed the ratings level you select. To watch programs that exceed the selected rating, you must enter a password.

Setting or changing the password

- 1 Press **MENU**.



- 2 Press **◀** or **▶** to highlight **Settings**, then press **ENTER**.

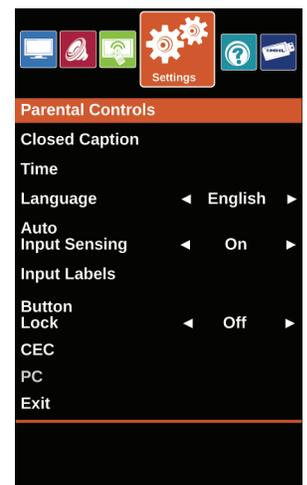

- 3 Press **▲** or **▼** to highlight **Parental Controls**, then press **ENTER**.



- 4 Press the number buttons to enter the four-digit password. The default password is **0000**. You should change the password to a number you can remember.

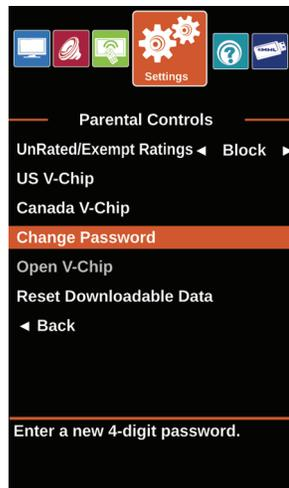

- 5 Press **▲** or **▼** to highlight **Change Password**, then press **ENTER**.



- 6 Press the number buttons to enter a password, then enter the password again. A message tells you that the password has been changed.

Note

If you forget your password, enter **9999**.

- 7 Press **MENU** to return to the previous menu, or press **EXIT** to close the menu.

Blocking unrated TV

Some TV programs, such as news and sports shows are not rated. When you set **UnRated/Exempt Ratings** to **Block**, TV programs that do not have ratings are blocked. When you try to watch a blocked program, you are prompted to enter the parental controls password.

- 1 Press **MENU**.



- 2 Press **◀** or **▶** to highlight **Settings**, then press **ENTER**.

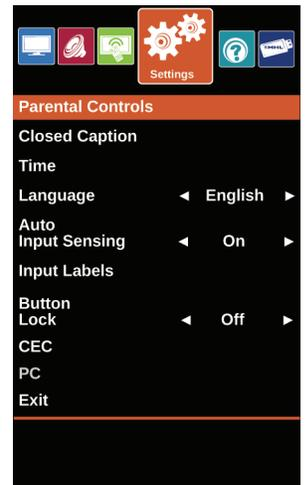

- 3 Press **▲** or **▼** to highlight **Parental Controls**, then press **ENTER**.



- 4 Press the number buttons to enter the four-digit password.

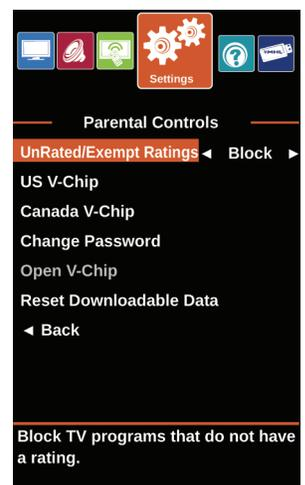

- 5 Press **▲** or **▼** to highlight **UnRated/Exempt Ratings**, then press **ENTER** or **▶** to access the option.
- 6 Press **◀** or **▶** to select **Block** (to block unrated TV) or **View** (to unblock unrated TV).
- 7 Press **MENU** to return to the previous menu, or press **EXIT** to close the menu.

Setting parental control levels

You can set parental controls for the U.S. and Canada.

U.S. rating levels

U.S. TV ratings	
NONE	Not rated
TV-Y	All children
TV-Y7	Suitable for children 7 and older
TV-G	General audiences
TV-PG	Parental guidance suggested
TV-14	Parental guidance strongly suggested
TV-MA	Mature audiences only

Some of the age-based TV Parental Guidelines ratings also have content-based ratings.

U.S. TV content ratings	
All	All ratings are blocked
FV	Fantasy violence
L	Strong language
S	Sexual situations
V	Violence
D	Suggestive dialog

U.S. movie (MPAA) ratings	
None	Movie not rated
G	General audiences
PG	Parental guidance suggested
PG-13	Suitable for children 13 and older
R	Parental guidance suggested for children under 17
NC-17	Not suitable for children under 17
X	Adults only

Canadian rating levels

Canadian English ratings	
E	Exempt programming
C	Suitable for all children
C8+	Suitable for children 8 and older
G	General audiences
PG	Parental guidance suggested
14+	Suitable for children 14 and older
18+	Adult only

Canadian French ratings	
E	Exempt programming
G	General audiences
8ans+	Suitable for children 8 and older
13ans+	Suitable for children 13 and older
16ans+	Suitable for children 16 and older
18ans+	Adult only

- 1 Press **MENU**.



- 2 Press **◀** or **▶** to highlight **Settings**, then press **ENTER**.

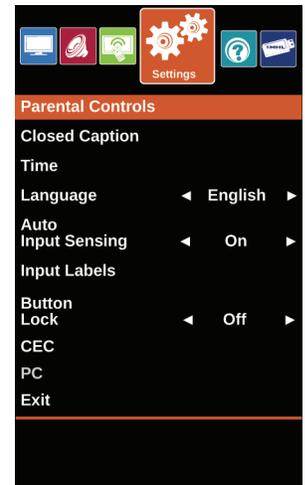

- 3 Press **▲** or **▼** to highlight **Parental Controls**, then press **ENTER**.



- 4 Press the number buttons to enter the four-digit password.

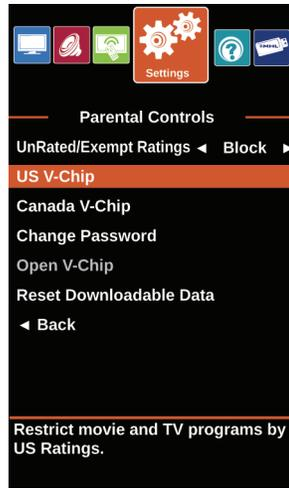

- 5 Press ▲ or ▼ to highlight **US V-Chip**, then press **ENTER**. (To set Canadian ratings, select **Canadian V-Chip**.)

US V-Chip

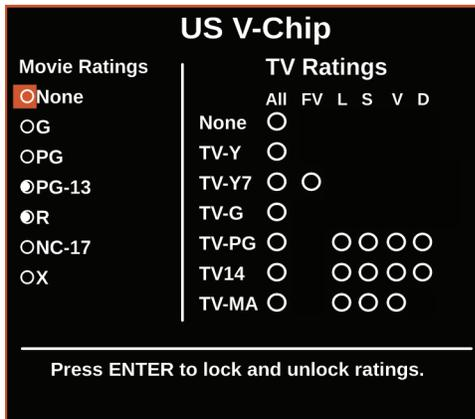

Canadian V-Chip

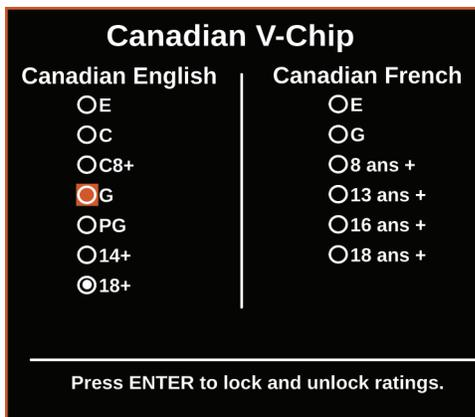

- 6 Press ◀ or ▶ to highlight:
- **Movie Ratings** or **TV Ratings** for USA ratings.
 - **Canadian English** or **Canadian French** for Canadian ratings.

- 7 Press ▲ or ▼ to select the rating. If a rating has sub-ratings, press ◀ or ▶ to highlight a sub-rating.

Note

When you block a rating, that rating and all higher ratings are blocked.

- 8 Press **ENTER** to confirm. A lock symbol appears when a rating is blocked.
- 9 Press **MENU** to return to the previous menu, or press **EXIT** to close the menu.

Downloading rating information

If the program you are viewing has downloadable rating information, you can download the information to use when setting parental controls.

Note

If the program you are viewing does not have V-Chip rating information, **Open V-CHIP** is grayed on the *Settings · Parental Controls* menu and cannot be selected.

- 1 Press **MENU**.



- 2 Press ◀ or ▶ to highlight **Settings**, then press **ENTER**.

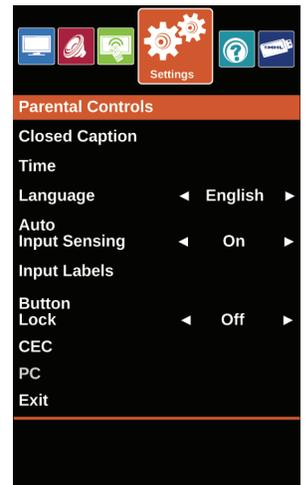

- 3 Press ▲ or ▼ to highlight **Parental Controls**, then press **ENTER**.



- 4 Press the number buttons to enter the four-digit password.

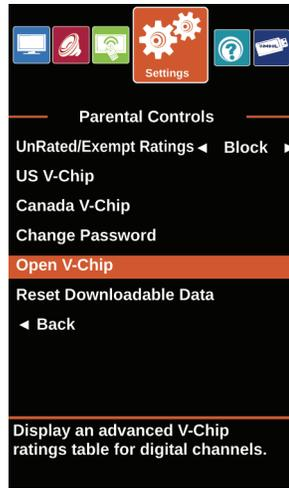

- 5 Press **▲** or **▼** to highlight **Open V-CHIP**, then press **ENTER**. The screen that you see may vary depending on the broadcaster.

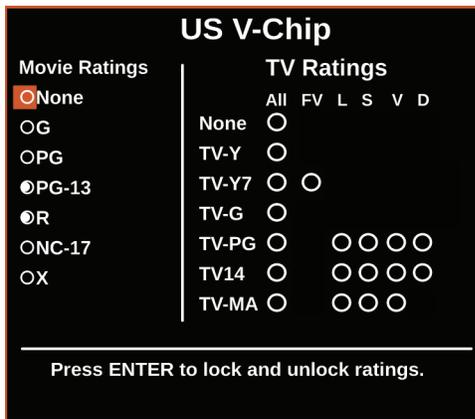

- 6 Press **▲** **▼** **◀** or **▶** to select the program and content types you want to block, then press **ENTER**.

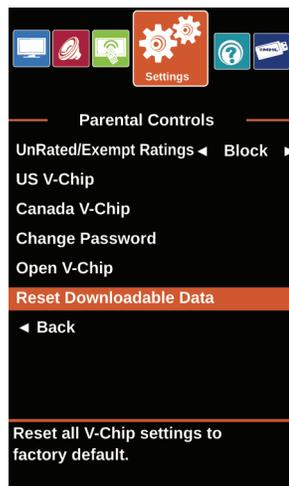

- 7 To reset the V-Chip information to the factory default, press **▲** or **▼** to highlight **Reset Downloadable Data**, then press **ENTER**. A box opens.
- 8 Press **▲** or **▼** to highlight **OK** or **Cancel**, then press **ENTER**.
- 9 Press **MENU** to return to the previous menu, or press **EXIT** to close the menu.

Locking control buttons

When the button lock is turned **On**, the buttons on the side of your TV are locked, and you can only operate your TV using the remote control.

- 1 Press **MENU**.



- 2 Press **◀** or **▶** to highlight **Settings**, then press **▼** or **ENTER**.

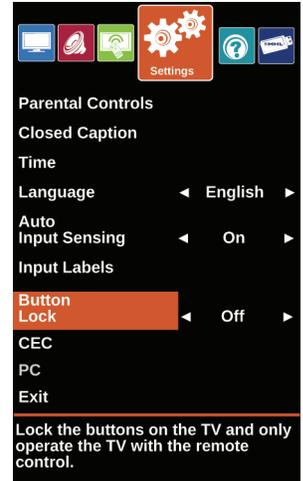

- 3 Press **▲** or **▼** to highlight **Button Lock**, then press **ENTER** or **▶** to access the option.
- 4 Press **◀** or **▶** to select **On** (locks the buttons) or **Off** (unlocks the buttons).
- 5 Press **MENU** to return to the previous menu, or press **EXIT** to close the menu.

Using closed captioning

Closed captioning displays a text version of the TV program audio or displays information provided by the broadcaster.

Turning closed captioning on or off

- 1 Press **MENU**.



- 2 Press **◀** or **▶** to highlight **Settings**, then press **ENTER**.

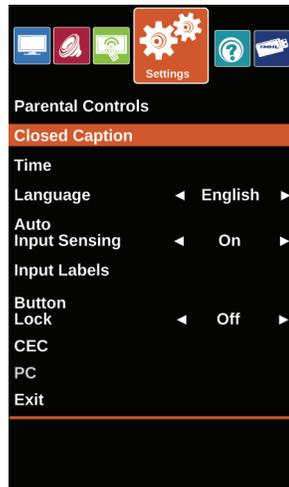

- 3 Press **▲** or **▼** to highlight **Closed Caption**, then press **ENTER**.

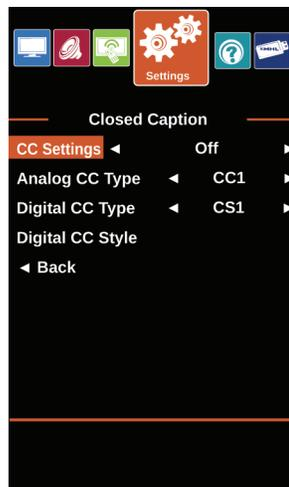

- 4 Press **▲** or **▼** to highlight **CC Settings**, then press **ENTER** or **▶** to access the option.
- 5 Press **◀** or **▶** to select **Off** (turns off closed captioning), **On Always** (turns on closed captioning), or **On When Mute** (turns on closed captioning when the sound is muted).
- 6 Press **MENU** to return to the previous menu, or press **EXIT** to close the menu.

Note

You can also press **CC** to turn closed captioning on or off.

Selecting the analog closed captioning mode

Analog channels usually have one or more closed captioning modes. The CC1 mode usually displays a text version of the TV program audio in a small banner. The other CC modes display information provided by the broadcaster. The Text modes display information in a box that covers half of the screen.

- 1 Press **MENU**.



- 2 Press **◀** or **▶** to highlight **Settings**, then press **ENTER**.

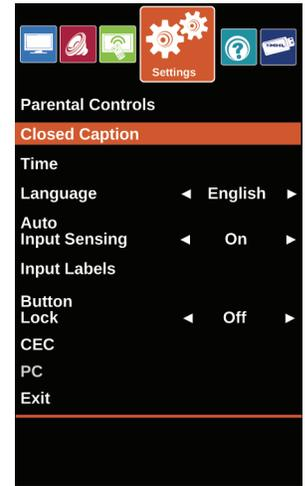

- 3 Press **▲** or **▼** to highlight **Closed Caption**, then press **ENTER**.

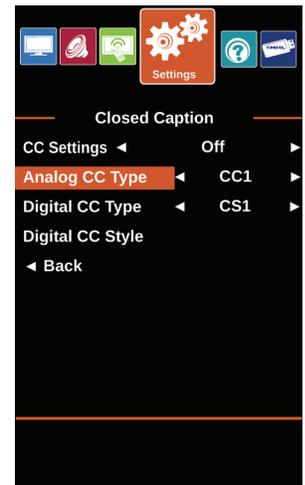

- 4 Press **▲** or **▼** to highlight **Analog CC Type**, then press **ENTER** or **▶** to access the option.
- 5 Press **◀** or **▶** to select an analog caption setting. You can select:
 - **CC1** through **CC4**—Closed captioning appears in a small banner across the bottom of the screen. **CC1** is usually the “printed” version of the audio. **CC2** through **CC4** display content provided by the broadcaster.
 - **Text1** through **Text4**—Closed captioning covers half or all of the screen. **Text1** through **Text4** display content provided by the broadcaster.
- 6 Press **MENU** to return to the previous menu, or press **EXIT** to close the menu.

Selecting the digital closed captioning mode

Digital channels usually have one or more closed captioning modes. The Service1 and CC1 modes usually display a text version of the TV program audio in a small banner. The other Service and CC modes display information provided by the broadcaster. Service1 mode displays a text version of the audio in the same language as the audio.

1 Press **MENU**.



2 Press ◀ or ▶ to highlight **Settings**, then press **ENTER**.

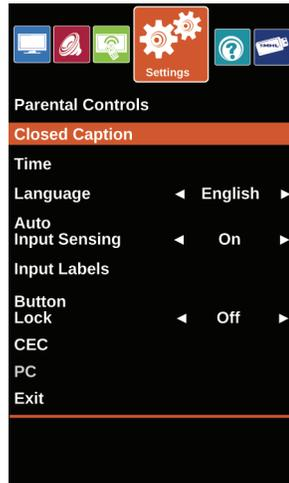

3 Press ▲ or ▼ to highlight **Closed Caption**, then press **ENTER**.

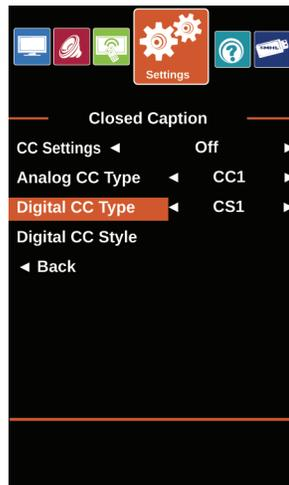

4 Press ▲ or ▼ to highlight **Digital CC Type**, then press **ENTER** or ▶ to access the menu.

5 Press ◀ or ▶ to select a digital caption setting. You can select:

- **Service1** through **Service6**—Service1 is usually the “printed” version of the audio. Service2 through Service6 display content provided by the broadcaster. You can change the way digital closed captioning is displayed on the screen. For more information, see “[Customizing digital closed captioning settings](#)” on page 67.
- **CC1** through **CS6**—Closed captioning appears in a small banner across the bottom of the screen. **CC1** is usually the “printed” version of the audio. **CC2** through **CC4** display content provided by the broadcaster.

6 Press **MENU** to return to the previous menu, or press **EXIT** to close the menu.

Customizing digital closed captioning settings

1 Press **MENU**.



2 Press ◀ or ▶ to highlight **Settings**, then press **ENTER**.

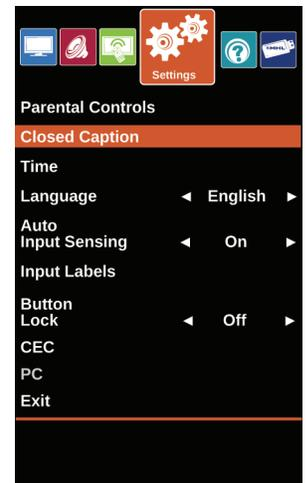

3 Press ▲ or ▼ to highlight **Closed Caption**, then press **ENTER**.

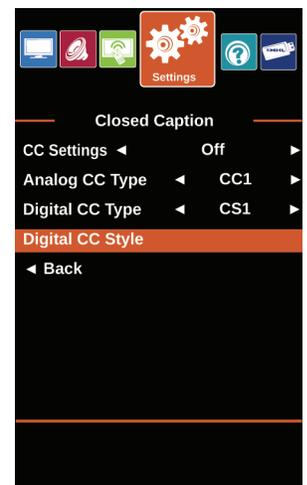

- Press **▲** or **▼** to highlight **Digital CC Style**, then press **ENTER**.



- Press **▲** or **▼** to highlight **Style**, then press **ENTER** or **▶** to access the option.
- Press **◀** or **▶** to highlight **Custom**, then press **ENTER**.
- Press **▲** or **▼** to highlight an option, then press **ENTER** or **▶** to access the option. You can select:
 - **Size**—Selects the font size.
 - **Font**—Selects the font style.
 - **Text Color**—Selects the color for the words.
 - **Text Opacity**—Selects the opacity level for the words.
 - **Background Color**—Selects the color for the background.
 - **Background Opacity**—Selects the opacity level for the background.
 - **Edge Effect**—Selects the style of the letter edges.
 - **Edge Color**—Selects the color of the letter edges.
- Press **◀** or **▶** to select a setting, then press **ENTER**.
- Press **MENU** to return to the previous menu, or press **EXIT** to close the menu.

Adjusting time settings

When you set up your TV for the first time, you set up the clock. If the power is disconnected or you move your TV to a different time zone, you need to reset the clock to the correct time.

Setting the clock

- Press **MENU**.



- Press **◀** or **▶** to highlight **Settings**, then press **ENTER**.

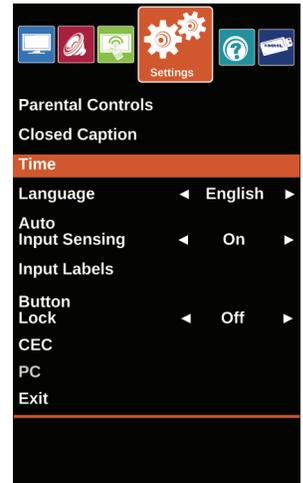

- Press **▲** or **▼** to highlight **Time**, then press **ENTER**.

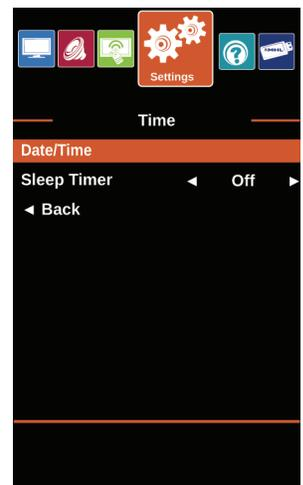

- 4 Press **▲** or **▼** to highlight **Date/Time**, then press **ENTER**.

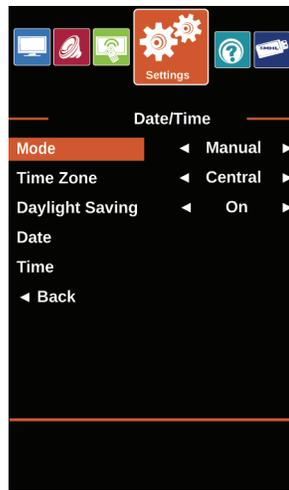

- 5 Press **▲** or **▼** to highlight **Mode**, then press **ENTER** or **▶** to access the option.
- 6 Press **◀** or **▶** to highlight **Manual** (to set the options manually) or **Auto** (the options are automatically set by the TV signal source), then press **ENTER**.
- 7 Press **▲** or **▼** to highlight **Time Zone**, then press **ENTER** or **▶** to access the option.
- 8 Press **◀** or **▶** to select your time zone, then press **ENTER**. You can select **Eastern, Central, Mountain, Pacific, Alaska, Hawaii, Atlantic, or Newfoundland**.
- 9 If your viewing area observes Daylight Saving Time, press **▲** or **▼** to highlight **Daylight Saving**, then press **ENTER** or **▶** to access the option.
- 10 Press **◀** or **▶** to select **On** or **Off**, then press **ENTER** to close the menu.
- 11 Press **▲** or **▼** to highlight **Date**, then press **ENTER**.
- 12 Press **◀**, **▶** or **ENTER** to highlight **Month**, **Day**, or **Year**, then press **▲** or **▼** to adjust the setting. When you are finished, use the arrow buttons to highlight **Next**, then press **ENTER**.
- 13 Press **▲** or **▼** to highlight **Time**, then press **ENTER**.
- 14 Press **◀**, **▶** or **ENTER** to highlight the **Hour**, **Minute**, or **AM/PM** field, then press **▲** or **▼** to adjust the setting. When you are finished, use the arrow buttons to highlight **Next**, then press **ENTER**.
- 15 Press **MENU** to return to the previous menu, or press **EXIT** to close the menu.

Setting the sleep timer

You can specify the amount of time before your TV automatically turns off.

- 1 Press **MENU**.



- 2 Press **◀** or **▶** to highlight **Settings**, then press **ENTER**.

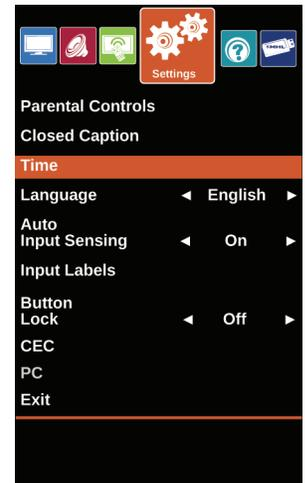

- 3 Press **▲** or **▼** to highlight **Time**, then press **ENTER**.

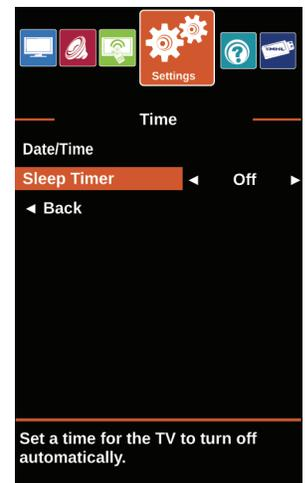

- 4 Press **▲** or **▼** to highlight **Sleep Timer**, then press **ENTER** or **▶** to access the option.
- 5 Press **◀** or **▶** to select the amount of time before your TV turns off automatically. You can select **Off, 5 minutes, 10 minutes, 15 minutes, 30 minutes, 60 minutes, 90 minutes, 120 minutes, 180 minutes, or 240 minutes**. To turn off the sleep timer, select **Off**.
- 6 Press **MENU** to return to the previous menu, or press **EXIT** to close the menu.

Note

You can also press **SLEEP** to set the sleep timer.

Adjusting menu settings

Selecting the menu language

Your TV can display the on-screen menu in English, French, or Spanish. When you set your TV up for the first time, you select the language. You can change the menu language to a different language.

- 1 Press **MENU**.



- 2 Press **◀** or **▶** to highlight **Settings**, then press **ENTER**.

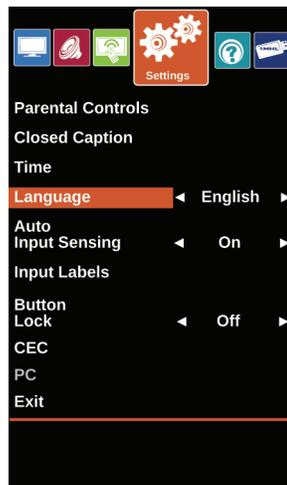

- 3 Press **▲** or **▼** to highlight **Language**, then press **ENTER** or **▶** to access the option.
- 4 Press **◀** or **▶** to highlight a language, then press **ENTER**. You can select **English**, **Français**, or **Español**.
- 5 Press **MENU** to return to the previous menu, or press **EXIT** to close the menu.

Turning Input Sensor on or off

When the Input Sensor feature is turned on, your TV automatically detects which video jacks have devices connected to them. Your TV uses this information to determine what options you can select on the *INPUT SOURCE* list when you press **INPUT**.

- 1 Press **MENU**.



- 2 Press **◀** or **▶** to highlight **Settings**, then press **ENTER**.

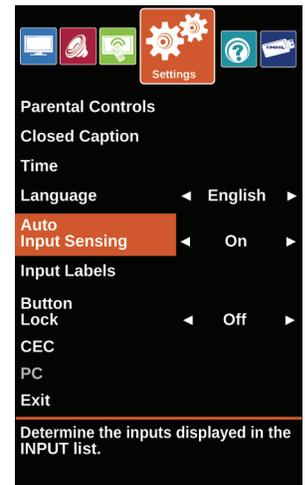

- 3 Press **▲** or **▼** to highlight **Auto Input Sensing**, then press **ENTER** or **▶** to access the option.
- 4 Press **◀** or **▶** to select **On** (turns on the input sensor) or **Off** (turns off the input sensor).
- 5 Press **MENU** to return to the previous menu, or press **EXIT** to close the menu.

Labeling an input source

You can add a label to an input source to make it easier to identify in the *INPUT SOURCE* list.

- 1 Press **MENU**.



- 2 Press **◀** or **▶** to highlight **Settings**, then press **ENTER**.

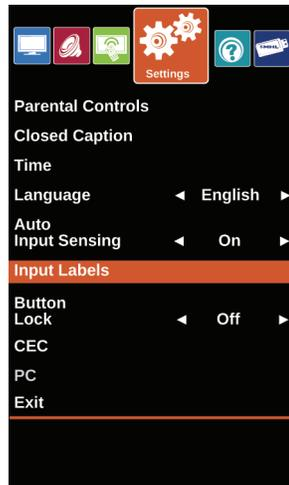

- 3 Press **▲** or **▼** to highlight **Input Labels**, then press **ENTER** or **▶** to access the option.

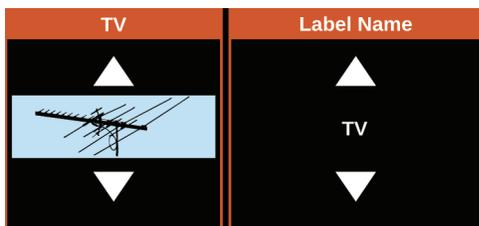

- 4 Press **▲** or **▼** to select the input source you want to label, then press **▶** to move to the label field.



- 5 Press **▲** or **▼** to select a character, then press **◀** or **▶** to move to the previous or next character position. Repeat this step to enter additional characters.
- 6 When you have completed the label, press **ENTER** to save your label and return to the previous menu. The next time you press **INPUT**, your label appears in the *INPUT SOURCE* list.
- 7 Press **EXIT** to close the menu.

Maintenance

- Do not use your TV in areas that are too hot or too cold, because the cabinet may warp or the screen may malfunction. Your TV works best in temperatures that are comfortable to you.
- Storage temperatures are 32° to 122°F (0° to 50°C).
- Working temperatures are 41° to 104°F (5° to 40°C).
- Do not place your TV in direct sunlight or near a heat source.

Cleaning the TV cabinet

Clean the cabinet with a soft, lint-free cloth. If the cabinet is especially dirty, moisten a soft, lint-free cloth in a weak detergent solution, squeeze the excess moisture from the cloth, then wipe the cabinet with the cloth. Use a clean cloth to dry the cabinet.

Cleaning the TV screen

Clean the screen with a soft, lint-free cloth.

Troubleshooting

Warning

Do not try to repair your TV yourself. Contact authorized service personnel.

Viewing system information

You may need to view system information during troubleshooting.

- 1 Press **MENU**.

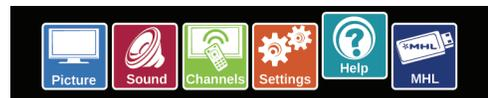

- 2 Press **◀** or **▶** to highlight **HELP**, then press **ENTER**.

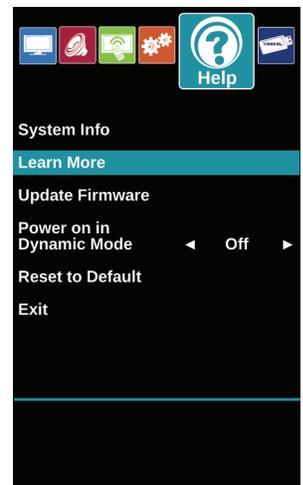

- 3 Press **▲** or **▼** to highlight **System Info**, then press **ENTER**. Information about the TV software version is displayed.



- 4 If your TV uses open source software, press **ENTER** to view the *Open Source Software Notice*.
- 5 Press **MENU** to return to the previous menu, or press **EXIT** to close the menu.

Learning more

You can learn more about Roku, MHL, remote control codes, and connecting a sound bar.

- 1 Press **MENU**.



- 2 Press **◀** or **▶** to highlight **HELP**, then press **ENTER**.



- 3 Press **▲** or **▼** to highlight **Learn More**, then press **ENTER**.

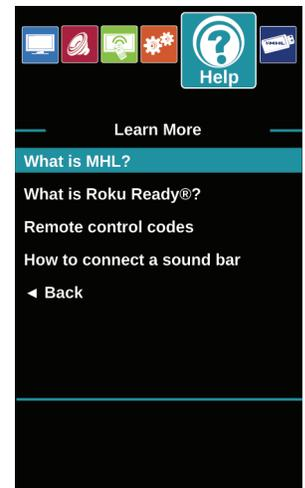

- 4 Press **▲** or **▼** to highlight a topic, then press **ENTER**. Your TV displays information about the topic you selected.
- 5 Press **MENU** to return to the previous menu, or press **EXIT** to close the menu.

Updating the TV firmware

If your TV is behaving oddly and you have tried all the solutions in the troubleshooting pages, you may need to update the TV firmware.

Cautions

- Make sure that you have tried all other solutions before you upgrade the firmware.
- While the firmware is updating, do not turn off your TV.

Note

To update the TV firmware, you need a:

- Computer with an available USB port
- High-speed Internet connection
- USB flash drive

- 1 On the *Help* menu, select **System Info**, then write down your model, revision, and firmware information. See "[Viewing system information](#)" on page 71.
- 2 Go to <http://www.sharpusa.com>.
- 3 Click **Support** in the upper right corner, then under **Consumer**, click **Product Downloads**.
- 4 Click **LED TVs**, then enter *LC-42LB261U* or *LC-50LB261U* in the **Enter LED TVs Model Number** box and click **Search**.
- 5 Under the image of your TV, click **Next**. If available, the most current firmware version is listed.
- 6 Download the firmware update and copy it to a USB flash drive.
- 7 Plug the USB flash drive into the USB port on the side of your TV. A message asks if you want to update the firmware.
- 8 Highlight **Yes**, then press **ENTER**.
- 9 Follow the on-screen instructions to install the update. **Do not turn off your TV until the update is complete.**
- 10 When the update is complete, unplug the USB flash drive, then press **ENTER**. Your TV turns off then on to complete the update.

11 If the channel list has been deleted, you need to scan for channels. For more information, see [“Automatically scanning for channels”](#) on page 57.

Note

- If you see a message that says the firmware file is incorrect, make sure that you have downloaded the correct file for your model.
- If you see a message that says the update failed or the TV screen is blank and the power LED is blinking red then blue, turn off your TV, turn it back on, then run the upgrade again.

Restoring settings to the defaults

When you restore default settings, all the settings you have customized (except parental controls) are reset.

1 Press **MENU**.



2 Press **◀** or **▶** to highlight **HELP**, then press **ENTER**.

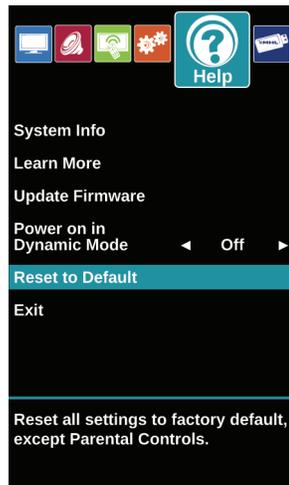

3 Press **▲** or **▼** to highlight **Reset to Default**. A message asks if you want to reset all TV settings to the default settings.

4 Press **▲** or **▼** to select **OK** (to reset) or **Cancel** (to not reset), then press **ENTER**.

If you select **OK**, your TV restarts and the *Easy Setup* wizard opens.

5 Go through the *Easy Setup* wizard. For more information, see [“Turning on your TV for the first time”](#) on page 40.

Video and audio

Problem	Solution
Picture does not fill the screen. There are black bars around the picture.	<ul style="list-style-type: none"> • Change the aspect ratio. An increasing amount of digital TV and movies are presented in wide screen (16:9). See the View Mode option in “Adjusting the TV picture” on page 52.
No picture (screen is not lit) and no sound.	<ul style="list-style-type: none"> • Press ⏻ on the TV or the remote control. • Make sure that the Audio Only option is set to Off. See “Playing TV audio only” on page 57. • Make sure that the video cables are connected securely to your TV. • Adjust the contrast and brightness. See “Adjusting the TV picture” on page 52. • Make sure that the power cord is plugged in. • Make sure that the correct video input source is selected. See “Selecting the video input source” on page 42. • Try another channel. The station may be experiencing problems. • Make sure that the incoming signal is compatible. • Make sure that the antenna or cable TV is connected correctly and securely. See “Connecting a cable or satellite box” on page 15 or “Connecting an antenna or cable TV (no box)” on page 20. • Check the closed caption settings. Some TEXT modes can block the screen.

Problem	Solution
Dark, poor, or no picture (screen is lit), but sound is good.	<ul style="list-style-type: none"> • Try another channel. The station may be experiencing problems. • Make sure that the antenna or cable TV is connected correctly and securely. See “Connecting a cable or satellite box” on page 15 or “Connecting an antenna or cable TV (no box)” on page 20. • Adjust the brightness. See “Adjusting the TV picture” on page 52. • Make sure that the correct picture mode is selected. See “Adjusting the TV picture” on page 52. • If you are using an antenna, the digital channel signal may be low. To check the digital channel signal strength, see “Checking the digital signal strength” on page 61. • If you are using an antenna and the signal strength is low, adjust the antenna or use a highly directional outdoor antenna or set-top antenna with a built-in amplifier. • Make sure that the video cables are connected securely to your TV. • The video cable(s) you are using may be bad. Try a new set. • Try another channel. The station may be experiencing problems.
No color, dark picture, or color is not correct.	<ul style="list-style-type: none"> • Try another channel. The station may be experiencing problems. • Adjust the color settings. See “Adjusting the TV picture” on page 52. • Make sure that the video cables are connected correctly and securely to your TV. • Make sure that the antenna or cable TV is connected correctly and securely. See “Connecting a cable or satellite box” on page 15 or “Connecting an antenna or cable TV (no box)” on page 20. • If you are using an antenna, the digital channel signal may be low. To check the digital channel signal strength, see “Checking the digital signal strength” on page 61. • If you are using an antenna and the signal strength is low, adjust the antenna or use a highly directional outdoor antenna or set-top antenna with a built-in amplifier.

Problem	Solution
Only snow (noise) appears on the screen.	<ul style="list-style-type: none"> • Try another channel. The station may be experiencing problems. • Make sure that the antenna or cable TV is connected correctly and securely. See “Connecting a cable or satellite box” on page 15 or “Connecting an antenna or cable TV (no box)” on page 20. • If you are using an antenna, the digital channel signal may be low. To check the digital channel signal strength, see “Checking the digital signal strength” on page 61. • If you are using an antenna and the signal strength is low, adjust the antenna or use a highly directional outdoor antenna or set-top antenna with a built-in amplifier.
Picture quality is good on some channels and poor on others. Sound is good.	<ul style="list-style-type: none"> • The problem may be caused by a poor or weak signal from the broadcaster or cable TV provider. • If you connect to cable or satellite TV without a set-top box and experience poor picture quality, you may need to install a set-top box to improve signal reception and picture quality. Contact your cable or satellite TV provider about upgrading to a set-top box.

Problem	Solution
Dotted lines or stripes appear on the screen.	<ul style="list-style-type: none"> • Make sure that the antenna or cable TV is connected correctly and securely. See “Connecting a cable or satellite box” on page 15 or “Connecting an antenna or cable TV (no box)” on page 20. • If you are using an antenna, the digital channel signal may be low. To check the digital channel signal strength, see “Checking the digital signal strength” on page 61. • If you are using an antenna and the signal strength is low, adjust the antenna or use a highly directional outdoor antenna or set-top antenna with a built-in amplifier. • Make sure that the video cables are connected securely to your TV. • The video cable(s) you are using may be bad. Try a new set. • Other devices (for example, a surround sound receiver, external speakers, fans, or hair dryers) may be interfering with your TV. Try turning off one device at a time to determine which device is causing interference. After you have determined which device is causing interference, move it further from the TV to eliminate the interference.
Double images.	<ul style="list-style-type: none"> • Use a highly directional outdoor antenna, cable TV, or satellite TV.
The picture has a few bright or dark spots.	<ul style="list-style-type: none"> • A few bright or dark spots on an LCD screen is normal. It does not affect the operation of your TV.

Problem	Solution
Good picture, but no sound.	<ul style="list-style-type: none"> • Increase the volume. • Make sure that the sound is not muted. • Make sure that you do not have headphones connected. When headphones are connected, no sound comes from the TV speakers. • Make sure that the correct audio mode is selected. • Make sure that the audio cables are connected correctly and securely to your TV. • Make sure that the antenna or cable TV is connected correctly and securely. See “Connecting a cable or satellite box” on page 15 or “Connecting an antenna or cable TV (no box)” on page 20. • If you are using an antenna, the digital channel signal may be low. To check the digital channel signal strength, see “Checking the digital signal strength” on page 61. • The audio cable(s) you are using may be bad. Try a new set.
Poor picture.	<ul style="list-style-type: none"> • Make sure that the room is not too bright. Light reflecting off the screen can make the picture difficult to see. • If an S-VHS camera or a camcorder is connected while another connected device is turned on, the picture may be poor. Turn off one or more devices.
Good sound, but poor color.	<ul style="list-style-type: none"> • Adjust the contrast, color, and brightness settings. See “Adjusting the TV picture” on page 52.
Audio noise.	<ul style="list-style-type: none"> • Other devices (for example, a surround sound receiver, external speakers, fans, or hair dryers) may be interfering with your TV. Try turning off one device at a time to determine which device is causing interference. After you have determined which device is causing interference, move it further from the TV to eliminate the interference.

Problem	Solution
No output from one of the speakers.	<ul style="list-style-type: none"> Adjust the audio balance. See “Adjusting sound settings” on page 55. Make sure that the audio cables are connected correctly and securely to your TV.
After images appear.	<ul style="list-style-type: none"> Do not display a still image, such as a logo, game, or computer image, for an extended period of time. This can cause a permanent after-image to be burned into the screen. This type of damage is not covered by your warranty.

Remote control

Problem	Solution
Remote control does not work.	<ul style="list-style-type: none"> Make sure that the power cord is correctly connected to your TV and a power outlet. Make sure that there are no obstructions between the remote control and the remote control sensor on the front of the TV. Point the remote control directly at the remote control sensor on your TV. For the location of the remote control sensor, see “Front” on page 10. The supplied batteries are wrapped tightly in clear plastic. Make sure that you have removed this plastic from the batteries. Make sure that the batteries are installed correctly. See “Installing remote control batteries” on page 38. Replace dead batteries with new batteries. See “Installing remote control batteries” on page 38.

General

Problem	Solution
No power.	<ul style="list-style-type: none"> Make sure that the power cord is correctly connected to your TV and a power outlet. Unplug the power cord, wait 60 seconds, then plug the cord back in and turn on your TV. Other devices (for example, a surround sound receiver, external speakers, fans, or hair dryers) may be interfering with your TV. Try turning off one device at a time to determine which device is causing interference. After you have determined which device is causing interference, move it further from the TV to eliminate the interference.

Problem	Solution
“No signal” error message is displayed.	<ul style="list-style-type: none"> Press INPUT and make sure that you have selected the correct input for the device or service you are trying to use. If you are using a cable or satellite box, use the remote that came with that box to change channels. Make sure that you have the correct input selected to view channels from the cable or satellite box.
After Auto Channel Search, there are no channels.	<ul style="list-style-type: none"> Reception can vary by channel depending on the broadcast power level of a given station. Contact your cable or satellite TV provider. Make sure that the antenna or cable/satellite TV is connected securely to your TV. Try replacing the cable between the antenna/cable or cable/satellite box and your TV.
One or more channels do not display.	<ul style="list-style-type: none"> Make sure that the channels are not blocked. See “Setting parental control levels” on page 63. Make sure that the channels are not hidden. The channel may have been deleted from the channel list. You can tune to the channel by pressing the number buttons or you can add the channel back to the channel list. See “Hiding channels” on page 58. If you are using a cable or satellite box, use the remote that came with that box to change channels. Make sure that you have the correct input selected to view channels from the cable or satellite box. If you are using an antenna, the digital channel signal may be low. To check the digital channel signal strength, see “Checking the digital signal strength” on page 61.
Password is lost.	<ul style="list-style-type: none"> Enter 9999 to access parental controls, then set a new password. See “Setting or changing the password” on page 61.
Some settings cannot be accessed.	<ul style="list-style-type: none"> If a setting is grayed, the setting is not available in the current video input mode.

Problem	Solution
TV cabinet creaks.	<ul style="list-style-type: none"> When the TV is in use, the temperature rises naturally and may cause the cabinet to expand or contract which can cause a creaking noise. This is not a malfunction.
Control buttons do not work.	<ul style="list-style-type: none"> Make sure that the Button Lock option is set to Off. See "Locking control buttons" on page 65. Unplug the power cord, wait a few seconds, then plug the cord back in and turn on your TV.
TV keeps turning off.	<ul style="list-style-type: none"> Make sure that the sleep timer is not turned on. See "Setting the sleep timer" on page 69.
A retail banner is displayed.	<ul style="list-style-type: none"> You selected "Store" mode when you ran the EZ SETUP wizard. Reset your TV to the factory defaults, then select Home on the <i>What is your viewing environment</i> screen. See "Restoring settings to the defaults" on page 73.

Roku Streaming Stick

Problem	Solution
I cannot see a picture on my TV.	<ul style="list-style-type: none"> Make sure that your TV is turned on. Make sure that the mobile device is securely connected to the purple HDMI 2/MHL jack. See "Connecting a Roku Streaming Stick" on page 24. Make sure that you have selected HDMI 2 (Roku) as the video input source. See "Selecting the video input source" on page 42. Try adjusting the picture settings on your TV. See "Adjusting the TV picture" on page 52.
I cannot hear sound.	<ul style="list-style-type: none"> Make sure that you have selected HDMI 2 (Roku) as the video input source. See "Selecting the video input source" on page 42. If you are using external speakers, a sound bar, or a home theater system, make sure that the audio cables are connected securely. See "Connecting external speakers or a sound bar" on page 34. If you are using external speakers, a sound bar, or a home theater system, make sure that the volume is turned up and not muted. If you are using external speakers, a sound bar, or a home theater system, make sure that you have selected the correct output mode. Try adjusting the audio settings on your TV. See "Adjusting sound settings" on page 55.
I cannot connect to my wireless network.	<ul style="list-style-type: none"> Make sure that there are no obstructions, like cement walls, between your Roku Streaming Stick and your wireless router. Make sure that you have selected the correct wireless router name on the "Wireless" screen. If your network requires a password, make sure that you have entered the correct password. Passwords are case sensitive. If you have turned off SSID broadcasting on your wireless router, select "My network is not shown" on the "Wireless" screen. If you are not getting three or more signal-strength bars above your wireless network, adjust the location of your wireless router.

Problem	Solution
I cannot stream Netflix movies through my Roku Streaming Stick.	<ul style="list-style-type: none"> Make sure that you have a Netflix unlimited streaming membership. Membership is required to instantly watch movies and TV episodes streaming from Netflix.
I cannot watch all channels through my Roku Streaming Stick.	<ul style="list-style-type: none"> Not all channels are available in Canada.

MHL-enabled device

Problem	Solution
The mobile device does not charge when connected to the HDMI 2/MHL jack.	<ul style="list-style-type: none"> Make sure that the MHL cable is connected securely to your TV and the device. See “Connecting an MHL-enabled device” on page 25. Make sure that you are using an MHL cable. An MHL cable may be difficult to identify. It may look like a micro USB-to-HDMI cable because the cable connectors are the same, but the cable itself is thinner. The cable also may not be labeled MHL.
My TV is not displaying the video or playing the audio from the connected mobile device.	<ul style="list-style-type: none"> Make sure that the MHL cable is connected securely to your TV and the device. Make sure that you are using an MHL cable. An MHL cable may be difficult to identify. It may look like a micro USB-to-HDMI cable because the cable connectors are the same, but the cable itself is thinner. The cable also may not be labeled MHL. Try adjusting the picture settings on your TV. Some apps may not work on your TV, depending on how the app developer programmed the app.
My TV is playing the audio from a connected device but is not displaying the video.	<ul style="list-style-type: none"> Make sure that the MHL cable is connected securely to your TV and the device. Make sure that you are using an MHL cable. An MHL cable may be difficult to identify. It may look like a micro USB-to-HDMI cable because the cable connectors are the same, but the cable itself is thinner. The cable also may not be labeled MHL. Try adjusting the picture settings on your TV. Some apps may not work on your TV, depending on how the app developer programmed the app.

Problem	Solution
My TV is displaying the video from the connected device but is not playing the audio.	<ul style="list-style-type: none"> Make sure that the volume on your mobile device is turned up and not muted. Make sure that the volume on your TV is turned up and not muted. Make sure that the MHL cable is connected securely to your TV and the device. Make sure that you are using an MHL cable. An MHL cable may be difficult to identify. It may look like a micro USB-to-HDMI cable because the cable connectors are the same, but the cable itself is thinner. The cable also may not be labeled MHL. Try adjusting the audio settings on your TV. Some apps may not work on your TV, depending on how the app developer programmed the app.

CEC-compatible device

Problem	Solution
My TV is not displaying the video from the connected CEC device.	<ul style="list-style-type: none"> Make sure that the HDMI cable is connected securely to your TV and the device. Make sure that the device is connected to your TV with an HDMI cable. Make sure that the device is a CEC-compatible device. See the documentation that came with the device for more information. Make sure that the correct video input source is selected. See “Selecting the video input source” on page 42. Make sure that the CEC Control feature is turned on. See “Turning CEC Control on or off” on page 46. Try adjusting the TV picture. See “Adjusting the TV picture” on page 52. If the device is not a Sharp device, it may not be compatible with your TV.

Problem	Solution
My TV is not playing the audio from the connected CEC device.	<ul style="list-style-type: none"> • Make sure that the HDMI cable is connected securely to your TV and the device. • Make sure that the device is connected to your TV with an HDMI cable. • Make sure that the device is a CEC-compatible device. See the documentation that came with the device. • Make sure that the TV volume is turned up and not muted. • Try adjusting the TV sound. See “Adjusting sound settings” on page 55. • Make sure that the TV speakers are turned on and not muted. See “Adjusting sound settings” on page 55. • Make sure that the CEC control feature is turned on. See “Turning CEC Control on or off” on page 46. • If you have connected an HDMI CEC audio receiver, adjust the volume on the receiver. When your TV detects an audio receiver, the TV speakers turn off and sound plays through receiver speakers only.
My TV's remote control does not control the device.	<ul style="list-style-type: none"> • Make sure that there are no obstructions between the remote control and the remote control sensors on your TV and the device. • If the device is not a Sharp device, all the buttons may not work. • Make sure that the CEC Control feature is turned on. See “Turning CEC Control on or off” on page 46. • If you are trying to control the volume on an HDMI CEC audio receiver using your TV remote control, make sure that the Audio Return Channel option on the CEC menu is set to On. See “Turning Audio Return Channel on or off” on page 48. • The device may not support this feature. See the documentation that came with the device for more information.

Problem	Solution
The device does not show up in the CEC Device list.	<ul style="list-style-type: none"> • Make sure that the device is turned on. • Make sure that the HDMI cable is connected securely to your TV and the device. • Make sure that the device is connected to your TV with an HDMI cable. • Make sure that the CEC Control feature is turned on. See “Turning CEC Control on or off” on page 46. • Make sure that the device is a CEC-compatible device. See the documentation that came with the device. • If the device is not a Sharp device, it may not be compatible with your TV.
My device does not turn off when I turn off my TV.	<ul style="list-style-type: none"> • Make sure that the CEC Control feature is turned on. See “Turning CEC Control on or off” on page 46. • Make sure that Device Auto Power Off is set to On on the CEC menu. See “Turning Device Auto Power Off on or off” on page 47. • The device may not support this feature. See the documentation that came with the device for more information.
My TV does not turn on when I turn on my device.	<ul style="list-style-type: none"> • Make sure that the CEC Control feature is turned on. See “Turning CEC Control on or off” on page 46. • Make sure that TV Auto Power On is set to On on the CEC menu. See “Turning TV Auto Power On or off” on page 47. • The device may not support this feature. See the documentation that came with the device for more information.

Problem	Solution
The Audio Return Channel setting on the CEC menu keeps turning back on after it is turned off.	<ul style="list-style-type: none"> When Audio Return Channel is set to Off and CEC Control is set to On and you adjust the volume on the audio receiver, Audio Return Channel is automatically set to On. To prevent this from happening, turn off the CEC Control feature. See "Turning CEC Control on or off" on page 46.

Problem	Solution
I cannot select the Root Menu option on the CEC menu. OR The device's root menu does not open when I select Root Menu on the CEC menu.	<ul style="list-style-type: none"> The device may not support this feature. See the documentation that came with the device for more information.

Note
If the problem is not solved by using these troubleshooting instructions, turn off your TV, then turn it on again.

Specifications

Specifications are subject to change without notice.

Dimensions and weight

	LC-42LB261U	LC-50LB261U
Without stand	37.7 × 22.2 × 2.5 in. (96 × 56.5 × 6.3 cm) 18.7 lb. (8.5 kg)	44.2 × 25.9 × 2.5 in. (112.4 × 65.7 × 6.3 cm) 29.3 lb. (13.3 kg)
With stand	37.7 × 23.3 × 9.2 in. (96 × 59.2 × 23.3 cm) 19.8 lb. (9 kg)	44.2 × 27 × 12.2 in. (112.4 × 68.5 × 31 cm) 31.1 lb. (14.1 kg)

Screen

	LC-42LB261U	LC-50LB261U
Screen size measured diagonally	42 in.	49.5 in.
Display type	LED	LED
Panel 60 Hz vs. 120 Hz	120Hz	120Hz
Display resolution	1080p	1080p
Panel resolution	1920 (H) × 1080 (V)	1920 (H) × 1080 (V)
Aspect ratio	16:9	16:9
Contrast ratio (typical)–panel	3,000:1	3000:1
Dynamic contrast ratio–list value	2,000,000:1	2,000,000:1
TV Brightness (minimum) cd/m²	240 nits	240 nits
Comb filter	3d y/c digital	3d y/c digital
Response time	5.5 ms	5.5 ms
Horizontal viewing angle	178°	178°
Vertical viewing angle	178°	178°

Display resolutions (both models)

HDMI suggested resolutions	1080p, 1080i, 720p, 480p, 480i
Component video suggested resolutions	1080i, 720p, 480p, 480i

Tuner (both models)

Analog	NTSC
Digital	ATSC, 8-VSB, Clear-QAM

Inputs (both models)

HDMI	3 (side) EDID and HDCP compliant MHL-enabled and Roku Ready® (HDMI 2/MHL jack)
Component video	1 (back)
Composite video	1 (back) Shared with component Y
Shared audio (component and composite)	Yes
PC/VGA	1 (back)
3.5mm PC audio input	1 (back)
DVI	1 (side) HDMI 3/DVI jack
USB	1 (side) Supports JPEG and firmware upgrade
Antenna/Cable	1 (back)

Outputs (both models)

Video	No
Analog audio/Headphone	1 (side)
Digital audio	1 (optical) (back)
WiFi	No
Ethernet	No

Audio (both models)

DTS Tuning Package	DTS Sound
Speakers	Number: 2 Watts per channel: 10W

Power

	LC-42LB261U	LC-50LB261U
Power consumption	On: 95W Standby: <1W	On: 120W Standby: <1W
Power input	AC 120 V, 60Hz	AC 120 V, 60Hz

Miscellaneous

	LC-42LB261U	LC-50LB261U
OSD languages	English, French, Spanish	English, French, Spanish
MHL-enabled and Roku Ready®	Yes (HDMI 2/MHL jack)	Yes (HDMI 2/MHL jack)
ENERGY STAR qualified	Yes	Yes
Internet connectable	No	No
TV base screws	Base to TV screen: M4 type (18 mm length) (4 pcs)	Base to TV screen: M6 type (20 mm length) (4 pcs)
V-Chip (version 2.0)	Yes	Yes
Sleep timer	Yes	Yes
Channel labeling	Yes	Yes
VESA mount (mm) (horizontal × vertical)	200 × 200	400 × 200
VESA mount screws	M6 type	M6 type

Note

The length of the wall-mount screws vary depending on the wall-mount bracket you purchased. See the instructions that came with the wall-mount bracket for screw lengths.

Legal notices

FCC Statement

This device complies with Part 15 of the FCC Rules. Operation is subject to the following two conditions: (1) this device may not cause harmful interference, and (2) this device must accept any interference received, including interference that may cause undesired operation. This equipment has been tested and found to comply with the limits for a Class B digital device, pursuant to Part 15 of the FCC Rules. These limits are designed to provide reasonable protection against harmful interference in a residential installation. This equipment generates, uses and can radiate radio frequency energy and, if not installed and used in accordance with the instructions, may cause harmful interference to radio communications. However, there is no guarantee that interference will not occur in a particular installation. If this equipment does cause harmful interference to radio or television reception, which can be determined by turning the equipment off and on, the user is encouraged to try to correct the interference by one or more of the following measures:

- Reorient or relocate the receiving antenna.
- Increase the separation between the equipment and receiver.
- Connect the equipment into an outlet on a circuit different from that to which the receiver is connected.
- Consult the dealer or an experienced radio/TV technician for help.

Warning

Changes or modifications not expressly approved by the party responsible for compliance could void the user's authority to operate the equipment.

Cables

Connections to this device must be made with shielded cables with metallic RF/EMI connector hoods to maintain compliance with FCC Rules and Regulations.

Canadian Notice

CAN ICES-3 (B)/NMB-3(B)
Standard Television Receiving Apparatus – Appareil de réception télévision ordinaire, NORMES CANADIENNES BETS-7 / NTMR-7

IC Statement

This device complies with Industry Canada licence-exempt RSS standard(s).

Operation is subject to the following two conditions: (1) this device may not cause interference, and (2) this device must accept any interference, including interference that may cause undesired operation of the device.

This equipment complies with IC radiation exposure limits set forth for an uncontrolled environment.

Dolby License Notice and Trademark Acknowledgement



Manufactured under license from Dolby Laboratories. Dolby and the double-D symbol are trademarks of Dolby Laboratories.

HDMI



The terms HDMI and HDMI High-Definition Multimedia Interface, and the HDMI Logo are trademarks or registered trademarks of HDMI Licensing LLC in the United States and other countries.

DTS Sound™



For DTS patents, see <http://patents.dts.com>. Manufactured under license from DTS Licensing Limited. DTS, the Symbol, & DTS and the Symbol together are registered trademarks and DTS Sound is a trademark of DTS, Inc. © DTS, Inc. All Rights Reserved.

MHL™ (Mobile High-Definition Link)



MHL and the MHL logo are trademarks or registered trademarks of MHL Licensing, LLC in the United States and other countries.

Energy Star



Your Sharp TV is ENERGY STAR® qualified in the "Standard" mode. It meets strict energy efficiency guidelines set by the U.S. Environmental Protection Agency and Department of Energy. ENERGY STAR is a joint program of these government agencies, designed to promote energy efficient products and practices. Changes to certain features, settings, and functionalities of this TV (i.e. Picture, Sound) can increase or change the power consumption. Depending upon such changed settings, the power consumption may exceed the limits required for the ENERGY STAR qualification in the "Standard" mode.

Open Source

Font name: Arimo

Version 1.23

Copyright 2013 Steve Matteson

Licensed under the Apache License, Version 2.0 (the "License"); you may not use this file except in compliance with the License. You may obtain a copy of the License at <http://www.apache.org/licenses/LICENSE-2.0>

Unless required by applicable law or agreed to in writing, software distributed under the License is distributed on an "AS IS" BASIS, WITHOUT WARRANTIES OR CONDITIONS OF ANY KIND, either express or implied. See the License for the specific language governing permissions and limitations under the License.

If you require additional information please call the Insignia support line at 1-877-467-4289.

One-year limited warranty - Sharp Televisions

Definitions:

Best Buy ("Warrantor") warrants to you, the original purchaser of this new Sharp-branded television ("Product"), that the Product shall be free of defects in the original manufacturer of the material or workmanship for a period of one (1) year from the date of your purchase of the Product ("Warranty Period"). For this warranty to apply, your Product must be purchased in the United States or Canada from a Best Buy or Future Shop authorized dealer of Sharp brand products only that are packaged with this warranty statement.

How long does the coverage last?

The Warranty Period lasts for 1 year (365 days) from the date you purchased the Product. Your purchase date is printed on the receipt you received with the Product.

What does this warranty cover?

During the Warranty Period, if the original manufacture of the material or workmanship of the Product is determined to be defective by an authorized Warrantor repair center or store personnel, Warrantor will (at its sole option): (1) repair the Product with new or rebuilt parts; or (2) replace the Product at no charge with new or rebuilt comparable products or parts. Products and parts replaced under this warranty become the property of Warrantor and are not returned to you. If service of Products or parts are required after the Warranty Period expires, you must pay all labor and parts charges. This warranty lasts as long as you own your Sharp Product during the Warranty Period. Warranty coverage terminates if you sell or otherwise transfer the Product.

How to obtain warranty service?

If you purchased the Product at a Best Buy or Future Shop retail store location and your television Product has a screen size of less than 42 inches, please take your original receipt and the Product to any Best Buy or Future Shop store. Make sure that you place the Product in its original packaging or packaging that provides the same amount of protection as the original packaging. If you purchased the Product from a Best Buy or Future Shop online web site, mail your original receipt and the Product to the address listed on the web site. Make sure that you put the Product in its original packaging or packaging that provides the same amount of protection as the original packaging.

To obtain in-home warranty service for a television with a screen 42 inches or larger, in the United States call 1-888-BESTBUY, Canada call 1-866-BESTBUY for Future Shop call 1-800-663-2275. Call agents will diagnose and correct the issue over the phone or will have an Sharp-approved repair technician dispatched to your home.

Where is the warranty valid?

This warranty is valid only in the United States and Canada at Best Buy or Future Shop branded retail stores or websites to the original purchaser of the product in the county where the original purchase was made.

What does the warranty not cover?

This warranty does not cover:

- Customer instruction/education
- Installation
- Set up adjustments
- Cosmetic damage
- Damage due to acts of God, such as power surges
- Accident(s)
- Misuse, unintentional or intentional
- Abuse, unintentional or intentional
- Negligence
- Commercial purposes/use, including but not limited to use in a place of business or in communal areas of a multiple dwelling condominium or apartment complex, or otherwise used in a place of other than a private home.
- Modification of any part of the Product, including the antenna
- Damage due to incorrect operation or maintenance
- Connection to an incorrect voltage or power supply
- Outages, static or other problems with over-the-air reception of the television broadcast signals.
- Attempted repair by any person not authorized by Warrantor to service the Product

- Products sold "as is" or "with all faults"
- Consumables, including but not limited to batteries (i.e. AA, AAA, C etc.)
- Products where the factory applied serial number has been altered or removed
- Loss or Theft of this product or any part of the product
- Failures or Damage caused by any contact including but not limited to liquids, gels or pastes.
- Up to three (3) pixel failures (dots that are dark or incorrectly illuminated) grouped in an area smaller than one tenth (1/10) of the display size or up to five (5) pixel failures throughout the display. (Pixel based displays may contain a limited number of pixels that may not function normally.)
- Problems with delay in motion or action of video images while playing first-person style video games.

REPAIR REPLACEMENT AS PROVIDED UNDER THIS WARRANTY IS YOUR EXCLUSIVE REMEDY FOR BREACH OF WARRANTY. WARRANTOR SHALL NOT BE LIABLE FOR ANY INCIDENTAL OR CONSEQUENTIAL DAMAGES FOR THE BREACH OF ANY EXPRESS OR IMPLIED WARRANTY ON THIS PRODUCT, INCLUDING, BUT NOT LIMITED TO, LOST DATA, LOSS OF USE OF YOUR PRODUCT, LOST BUSINESS OR LOST PROFITS. WARRANTOR MAKES NO OTHER EXPRESS WARRANTIES WITH RESPECT TO THE PRODUCT, ALL EXPRESS AND IMPLIED WARRANTIES OF THE PRODUCT, INCLUDING, BUT NOT LIMITED TO, ANY IMPLIED WARRANTIES OF AND CONDITIONS OF MERCHANTABILITY AND FITNESS FOR A PARTICULAR PURPOSE, ARE LIMITED IN DURATION TO THE WARRANTY PERIOD SET FORTH ABOVE AND NO WARRANTIES, WHETHER EXPRESS OR IMPLIED, WILL APPLY AFTER THE WARRANTY PERIOD. SOME STATES, PROVINCES AND JURISDICTIONS DO NOT ALLOW LIMITATIONS ON HOW LONG AN IMPLIED WARRANTY LASTS, SO THE ABOVE LIMITATION MAY NOT APPLY TO YOU. THIS WARRANTY GIVES YOU SPECIFIC LEGAL RIGHTS, AND YOU MAY ALSO HAVE OTHER RIGHTS, WHICH VARY FROM STATE TO STATE OR PROVINCE TO PROVINCE.

Product information:

For the U.S., go to: <http://www.sharppusa.com/manuals/hd.aspx>

For Canada (English), go to:

<http://www.sharp.ca/en-CA/CustomerSupport/Support/ProductDownloads.aspx>

For Canada (French), go to:

<http://www.sharp.ca/fr-CA/CustomerSupport/Support/ProductDownloads.aspx>

Product support (855) 544-2030

This product is manufactured for Best Buy China Ltd, as trustee for Best Buy China, and distributed and warranted by Best Buy Purchasing, LLC (7601 Penn Avenue South, Richfield, Minnesota, U.S.A. 55423-3645) under brand license by SHARP Corporation.

©2015 Best Buy China LTD. All rights reserved.

SHARP is a registered trademark of Sharp Corporation; used under license by SHARP Corporation. All other trademarks are property of their respective owners.

SHARP®

Product information:

For the U.S., go to:

<http://www.sharppusa.com/manuals/hd.aspx>

For Canada (English), go to:

<http://www.sharp.ca/en-CA/CustomerSupport/Support/ProductDownloads.aspx>

For Canada (French), go to:

<http://www.sharp.ca/fr-CA/CustomerSupport/Support/ProductDownloads.aspx>

Product support (855) 544-2030

This product is manufactured for Best Buy China Ltd, as trustee for Best Buy China, and distributed and warranted by Best Buy Purchasing, LLC (7601 Penn Avenue South, Richfield, Minnesota, U.S.A. 55423-3645) under brand license by SHARP Corporation.

©2014 Best Buy China LTD. All rights reserved.

SHARP is a registered trademark of Sharp Corporation; used under license by SHARP Corporation.

All other trademarks are property of their respective owners.



V5 ENGLISH
14-1107